BELARUS

1025.5

1025.5-0000010 OM

OPERATOR'S MANUAL

2012

The operator's manual was composed by an engineer of the first Department of Constructive and Experimental Works (DCEW), A.V. Runov, with participation of key specialists of DCEW-1 of RUE "Minsk Tractor Works"

Publication responsible person – Y.M. Korotky, head of engineering office of design documentation of the DCEW-1.

Executive editor – A.G. Stasilevich, design manager of tractor production of PA "MTW".

Editor-in-chief – I.N. Uss, PA "MTW" chief designer.

Operator's manual contains brief description and specifications of tractors Belarus 1025.5 produced by Minsk Tractor Works. The main tractors operating rules are set forth, the information about their adjustments and maintenance is provided.

Operator's manual is meant for tractor study, operation rules and servicing of tractors "BELARUS-1025.5".

In view of P/A "MTW" policy directed to constant upgrading of produced goods, the construction of some units and parts of Belarus tractor may undergo changes which are not reflected in present edition. The detailed information may be obtained from "BELARUS" dealer.

1 TRACTOR DESCRIPTION AND OPERATION	10
1.1 Tractor assignment	10
1.2 Technical specifications	11
Table 1.1 finished	13
1.3 Tractor composition	14
1.4 Vibration level at the operator's working place of the tractor "BELARUS-1025.5"	16
1.5 Noise level at the operator's working place of the tractor "BELARUS-1025.5"	16
1.6 Tractor and its component marking	16
2 CONTROLS AND INSTRUMENTS	18
2.1 Layout of controls and instruments of the tractor	18
2.2 Switches of instrument board	19
2.3 Upper shield unit of button switches and rear wiper switch	21
2.4 Cab heater and fan control	22
2.5 Conditioner control	23
2.5.1 Conditioner control in conditioning mode	23
2.5.2 Conditioner control in a heating mode	23
2.5.3 Cab ventilation	24
2.6 Instrument board	25
2.7 Pilot lamps unit	27
2.7.1 General information	27
2.7.2 Functioning algorithm of pilot lamp to indicate operation of heating plugs	28
2.8 Integrated indicator	29
2.8.1 General information	29
2.8.2 Assignment and operation principle of integrated indicator gauges	29
2.8.3 Pilot lamps of the integrated indicator	32
2.8.4 Description of testing the indicator performance	33
2.8.5 Programming panel of integrated indicator	33
2.9 Engine control panel	35
2.9.1 General information	35
2.9.2 Information display	35
2.9.2.1 General information	35
2.9.2.2 Adjustment of brightness and sharpness of the information display	36
2.9.2.3 Call up of changeable images and parameters on the screen of the information display	36
2.10 Steering	39
2.10.1 General information	39
2.11 Parking brake control	39
2.12 Handle for fuel feed manual control	39
2.13 Tractor pedals	39
2.14 Switching of ranges and gears of gearbox	40
2.14.1 General information	40
2.14.2 Tractor velocity diagram	40
2.15 Control panel for rear axle DL, FDA drive	41
2.15.1 General information	41
2.15.2 Rear axle DL control	41
2.15.3 Front driving axle (FDA) drive control	42
2.16 Rear power take-off shaft control	43
2.16.1 Lever shifting rear PTO from continuous drive to ground-speed drive	43
2.16.2 Rear power take-off shaft engagement	43
2.16.3 Two-speed continuous drive of rear PTO switch	43
2.16.4 Tractor operation without use of rear PTO	43
2.17 Rear lift linkage control	44
2.17.1 RLL control elements	44

2.17.2 General information about RLL control rules	44
2.18 HLL pump control	46
2.19 Hydraulic lift linkage distribution valve sections (remote cylinders) control	46
2.19.1 Control of remote hydraulic cylinders with distribution valve RP70-1221 or RP70-1221.1 or RS213Mita installed by means of levers.	46
2.19.2 Control of remote hydraulic cylinders with distribution valve RP70-622 or RP70-622.1 installed by means of joystick and lever	48
2.20 Cutout fuses	49
2.20.1 General information	49
2.20.2 Fuses for electrical equipment system	49
2.20.3 Fuses for electronic systems to control DL and FDA	50
2.20.4 Fuse for engine electronic control system	51
2.21 Cab locks and handles	54
2.21.1 Cab door locks	54
2.21.2 Left-side window opening	54
2.21.3 Rear window opening	55
2.25.1 Socket to connect coupled agricultural equipment	59
2.25.2 Connection of additional electrical equipment of coupled machines	59
2.26 Creeper control	60
3 INTENDED USE OF TRACTOR	61
3.1 Safety measures to be taken preparing tractor for operation	61
3.2 Tractor use	62
3.2.1 Boarding the tractor	62
3.2.2 Preparing for start and starting the engine	62
3.2.3 Tractor motion start, GB shifting	63
3.2.4 Tractor stop	65
3.2.5 Engine stop	65
3.2.6 Leaving the tractor	65
3.2.7 PTO use	65
3.2.8 Selection of optimal inner pressure in tires depending on operational conditions and load on tractor axles	67
3.2.8.1 Selection of optimal inner pressure in tires depending on operational conditions and load on tractor axles.	67
3.2.8.2 Tire inflation	68
3.2.9 Rear wheel track formation	69
3.2.10 Rear wheel twinning	70
3.2.11 Front wheel track formation	70
3.3 Safety measures to be taken when operating the tractor	73
3.3.1 General safety measures to be taken when operating the tractor	73
3.3.2 Fire safety measures	76
3.4 Tractor final assembly and run-in	77
3.4.1 Tractor final assembly	77
3.4.2 Technical maintenance before tractor run-in	77
3.4.3 Tractor run-in	77
3.4.4 Technical maintenance during tractor run-in	78
3.4.5 Technical maintenance after tractor run-in	78
3.5 Emergency actions	79
4 COUPLING OF IMPLEMENTS	80
4.1 General information	80
4.2 Types of implements coupled with tractor "BELARUS-1025.5"	81
4.3 Rear lift linkage	82
4.3.1 General information	82
4.3.2 Three-point rear lift linkage	82

4.3.3 RLL components adjustment rules	85
4.3.3.1 Buckles	85
4.3.3.1.1 General information.....	85
4.3.3.1.2 Telescopic buckles.....	85
4.3.3.1.3 Turnbuckles	87
4.3.3.2 Lifting rod.....	88
4.3.3.3 Upper link	89
4.3.4 Attachment of implements to a tractor.....	89
4.4 Drawbar hitches	90
4.4.1 General information	90
4.4.2 Drawbar hitch DH-2V (short towing yoke).....	91
4.4.3 Drawbar hitch DH-3V (long towing yoke).....	92
4.4.4 Drawbar hitch DH-2R (python)	93
4.4.5 Drawbar hitch DH-1M-01 (draw bar).....	94
4.4.6 Drawbar hitch DH -1 (crossbeam)	95
4.5 Usage patterns of tractor hydraulic system for driving of operated parts and other elements of unitized hydraulically operated machines and aggregates	96
4.6 Front ballast weight installation	97
4.7 Trailer brake actuator	98
4.7.1 General information	98
4.7.2 Double-line pneumatic drive of trailer brakes	98
4.7.3 Hydraulic drive of trailer brakes.....	99
4.7.3.1 General information.....	99
4.7.3.2 Adjustment of hydraulic actuator of trailer brakes	100
4.8 Determination of PTO shaft and cardan shaft applicability.....	101
4.9 Features of application of PTO shafts and cardan shafts.....	101
4.10 Ways of changing of drawbar features and passing ability of the tractors	105
4.11 Features of the tractor application in special conditions	106
4.11.1 Tractor operation in areas with rugged topography.	106
Possibility of the tractor application for haulage allocation for reserve.	106
4.11.2 Application of substances for the purpose of chemical treatment	106
4.11.3 Operation in a forest.....	106
4.12 Finding of total weight, loads on the front and rear axles, tires holding capacity and required minimum ballast	107
4.13 Possibility of front loader installation.....	109
4.13.1 General information.....	109
4.13.2 Safety measures at tractor “BELARUS-1025.5” operation with loader installed....	111
4.13.3 Information about mounting holes of tractor	113
5 MAINTENANCE	115
5.1 General instructions.....	115
5.2 Providing access to the components for maintenance services.....	117
5.3 Maintenance procedure.....	118
5.4 Scheduled maintenance servicing operations	121
5.4.1 Maintenance on a shift basis (SBMS) in every 8 – 10 hours of operation or per shift	121
5.4.2 Maintenance services in every 125 hours of operation	127
5.4.3 Maintenance services in every 250 hours of operation (2MS-1), in every 500 hours of operation (MS-2), in every 1000 hours of operation (MS-3), in every 2000 hours of operation (special maintenance) and maintenance service that is inconsistent with intervals of MS-1, 2MS-1, MS-2, MS-3 and special MS.....	131
5.4.3.1 General instructions	131
5.4.3.2 Operation 29. Check/adjustment of clearances in steering joints.....	131
5.4.3.3 Operation 30. Check and adjustment of wheels toe-in.....	132

5.4.4 General maintenance services.....	133
5.4.4.1 General guidelines	133
5.4.4.2 Operation 67. Adjustment of valves of GB driven centrifuge	133
5.4.4.3 Operation 68. Adjustment of oil pressure in the engine lubrication system.....	134
5.4.4.4 Operation 69. Maintenance of engine air cleaner	135
5.5 Seasonal maintenance services.....	136
5.6 Safety measures during maintenance and repair operations.....	137
5.6.1 General safety requirements	137
5.6.2 Safety precautions for exclusion of hazardous situations, related to an accumulator battery and a fuel tank	137
5.6.3 Guidelines for safe use of leveling jacks and statement of places where they shall be installed	138
5.7 Filling and lubrication of the tractor with fuel and lubrication materials	140
6. POSSIBLE MALFUNCTIONS AND GUIDELINES FOR TROUBLESHOOTING.....	145
7 TRACTOR STORAGE.....	155
7.1 General instructions.....	155
7.2 Requirements for inter-shift storage of machines.....	155
7.3 Requirements for short-term tractors storage	155
7.4 Requirements for outdoors long-term storage	156
7.5 Preservation	157
7.6 Depreservation and representation.....	157
7.7 Putting tractor into operation after long-term storage.....	157
7.8 Safety requirements for preservation.....	158
8. TRACTOR TOWING.....	158
SERVICE BULLETINS	159

Introduction

The present manual is designed for studying the structure, operation rules and maintenance of tractors "BELARUS-1025.5".

Scrutinize this manual. It will help you to study the rules of correct operation and maintenance.

Failure to follow this instruction can lead to operator's injury or a breakdown of a tractor.

Operation of a tractor, its maintenance and repair shall be carried out only by employees, familiar with all of its parameters and characteristics and informed about necessary safety requirements to prevent casualties.

In connection with constant development of the tractor some changes, which are not depicted in the present manual, can be introduced in the structure of certain units and parts.

Any arbitrary changes made by a consumer release the manufacturer from responsibility for possible further injuries to the operator and tractor breakdown.



















Adopted abbreviations and conventional notations:

ADL – automatic differential lock;
 AB – accumulator battery;
 DL – differential lock;
 RADL – rear axle differential lock;
 PLU – pilot lamps unit;
 FB – fuse block;
 FC – fast coupling;
 PTO – power takeoff shaft;
 PRS – power reception shaft;
 HSC – hydrostatic steering control;
 HLL – hydraulic lift linkage;
 HS – hydraulic system;
 FFVS – frequency fuel volume sensor;
 STM – shift-time maintenance;
 SPTA – spare parts, tools and accessories;
 RA – rear axle;
 RLL – rear lift linkage;
 II – integrated indicator;
 GB – gearbox;
 MTU – machine and tractor unit;
 CC – coupling clutch;
 LL – lift linkage;
 IAH – inlet air heater;
 FDA – front driving axle;
 VC – voltage converter;
 FDAD – front driving axle drive;
 CM – control module;
 IICP – integrated indicator control module;
 HPH – high pressure hoses;
 HP – heating plugs;
 SM – seasonal maintenance;
 MS – maintenance service;
 MS1 – maintenance service No1;
 MS2 – maintenance service No2;
 MS3 – maintenance service No3;
 DH – drawbar hitch;
 ECS – electronic control system;
 EECS – engine electronic control system;
 EE – electrical equipment.

The manufacturer uses standard international symbols, regarding application of instruments and control units.

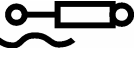
Given below are the symbols with indication of their meanings.

	— see the manual ;		— control manipulations;
	— brake;		— fast;
	— manual brake;		— slowly;
	— audible beep;		— forward;
	— alarm signaling;		— reverse;
	— fuel;		— accumulator charging;
	— coolant;		— cab roof light;
	— heating plugs;		— parking lights;
	— engine speed;		— tractor turn indicator;
	— oil pressure in the engine;		— trailer turn indicator;
	— temperature of engine coolant;		— upper beam;
	— off / stop;		— low beam;
	— on / start;		— working lights;
	— gradual adjustment;		— differential lock;
			— PTO engaged;

- | | | | |
|---|---|---|-----------------------------------|
|  | — front screen wiper; |  | — front driving axle drive; |
|  | — rear screen wiper and washer; |  | — fan; |
|  | — brake fluid level in main cylinder tanks; |  | — air filter clogged; |
|  | — oil pressure in HSC |  | — engine start; |
|  | — beacon |  | — road-train |
|  | — oil pressure in gearbox |  | — external cylinder – retracting |
|  | — braking of gearbox |  | — external cylinder – protracting |
|  | — air pressure in pneumatic system |  | — external cylinder – floating |
|  | — swivel lever – up |  | — engine stop |
|  | — swivel lever – down | | |

1 TRACTOR DESCRIPTION AND OPERATION

1.1 Tractor assignment

The tractor “BELARUS-1025.5” is intended for performance of various general – purpose agricultural operations with mounted, semi-mounted and trailed machines and implements, for loading-unloading works and transportation works.

The tractor “BELARUS-1025.5” is a general-purpose wheeled tractor of traction class 1,4 with the wheel formula 4X4.

Appearance of the tractor “BELARUS-1025.5” is presented in figures 1.1.1.

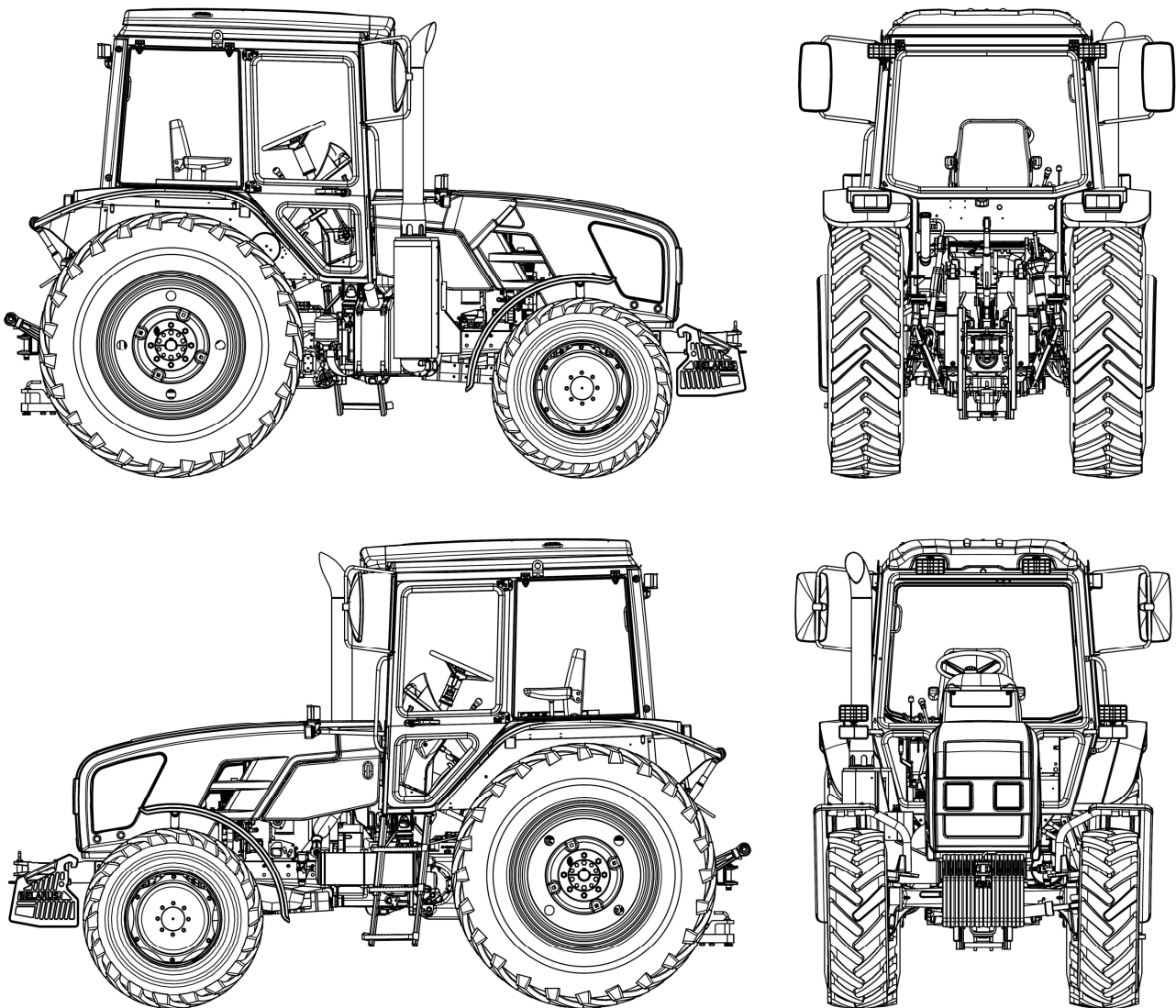

Figure 1.1.1 – Basic configuration of tractor “BELARUS-1025.5”

1.2 Technical specifications

Main parameters and technical specifications of tractor BELARUS-1025.5 are given in table 1.1.

Table 1.1

Parameter (characteristics) title	Parameter value for the tractor "BELARUS-1025.5"
1 Traction class as per GOST 27021	1,4
2 Rated traction force, kN	14
3 Engine ¹⁾	D-245S3B
a) model	turbocharged with intercooling of the charged air
b) engine type ²⁾	
c) number and position of cylinders ²⁾	four, in-line, vertical
d) displacement, l ²⁾	4,75
e) engine power, kW:	
1) rated ²⁾	81,0±2,0
2) normal	77,8±2,0
f) crankshaft rated speed, rpm ²⁾	2200
g) specific fuel consumption at normal power, g/(kW·h)	(234+7)
h) turning torque rated factor, % ²⁾	25
i) max turning torque, N·m ²⁾	440±18
4 Number of gears:	
a) for forward travel	16 ³⁾
b) for backward travel	8 ³⁾
5 Tractor travel speed (design) at crankshaft rated speed, km/h:	
a) for forward motion:	
1) least	2,3 ³⁾
2) highest	36,6
b) for backward motion:	
1) least	4,1 ³⁾
2) highest	17,2
6 Tractor weight, kg:	
a) structural	4200±100
b) operating with ballast	5335±100
c) operating without ballast	4805±100
d) max. operating	8000
e) ex-works ⁴⁾	4900
7 Distribution of operating weight on axles, kg:	
a) on front	2365±40 ⁵⁾ (1780 ⁶⁾)
b) on rear	2970±60 ⁵⁾ (3025 ⁶⁾)

Table 1.1 continued

Parameter (characteristics) title	Parameter value for the tractor "BELARUS-1025.5"
8 Permitted load on axles, kN: a) on front b) on rear	38 53
9 Max weight of the trailer, kg a) without brakes b) with independent brake c) with overrunning brake d) equipped with a brake system (trailer brakes are interconnected with tractor brakes)	2200 3750 3750 18000
10 Clearance, mm (on tyres of basic configuration) not less than: a) road b) agrotechnical under rear wheel assemblies	450 645
11 Track dimensions (on tyres of basic configuration), mm: a) on front wheels for short beam b) on front wheels for long beam c) for rear wheels	1415±20, 1515±20, 1585±20, 1685±20, 1735±20, 1835±20, 1900±20, 2000±20 1535±20, 1635±20, 1705±20, 1805±20, 1855±20, 1955±20, 2020±20, 2120 ±20 o1500±20 to 1600±20 and 1800±20 to 2100 ±20
12 Least radius of turning circle (with braking), m	4,6
13 Tractor base, mm	2570±20
14 Maximum fordable depth, m	0,85
15 Service life, years	12
16 Overall dimensions, mm: a) length with lift linkage in transport position b) length over external diameters of wheels c) width on rear wheel axle shaft ends d) height to the top of cab	4600±50 3650±50 1970±20 2825±30
17 Tyres (basic configuration): a) front wheels b) rear wheels	360/70R24 18.4R34
18 Electrical equipment as per GOST 3940: a) rated supply voltage in on-board power system, V b) rated ignition voltage, V	12 12

Table 1.1 finished

Parameter (characteristics) title	Parameter value for the tractor "BELARUS-1025.5"
21 Hydraulic system: a) pump displacement under crankshaft rated speed, l/min, not less than b) safety valve operation pressure, MPa c) conventional volume factor, not less than	 56 20.2 0,75
22 Working equipment: a) rear power take-off shaft: 1) rated speed of PTO shaft end with the ground-speed drive on, rpm: - position I (under the engine crankshaft speed of 2037 rpm) - position II (under the engine crankshaft speed of 2157 rpm) 2) rated speed of PTO shaft end with the continuous drive on, rev/meter of travel: b) rear lift linkage: 1) loading capacity of rear lift linkage on suspension axis, kg, not less than 2) time for raising rear lift linkage from lowermost position into uppermost position with test load on suspension axis, sec., not more than e) drawbar hitch:	 540 (583 ⁷⁾) 1000 (1020 ⁷⁾) 3,5 (on rear tires of standard configuration (18.4R34)) 4200 3 In section 4 "Coupling of implements"
1) Engine parameters, not specified in the table 1.1, shall meet 245 S3B – 0000100 OM document. 2) For referential use. 3) Without a creeper. Installation of a creeper against order provides additional four speeds for forward travel and four speeds for the reverse. 4) Specified depending on the configuration. 5) With ballast weights mounted. 6) Without ballast weights. 7) At 2200 rpm of engine crankshaft speed.	

1.3 Tractor composition

Tractor framework – semi-frame.

Undercarriage: front and rear driving wheels, with pneumatic tyres of low pressure. Steering wheels are front wheels. The wheels can be twinned by means of spacers.

The tractor is equipped with 4-stroke piston four-cylinder inner combustion engine with in-line vertical arrangement of cylinders, with direct injection of diesel fuel and compression ignition, corresponding to environmental requirements of Stage 3B.

System of engine lubrication is combined, some parts are lubricated under pressure, some – by spattering. The lubrication system consists of an oil sump, oil pump, liquid-oil heat exchanger, oil filter and oil filter with paper filtering element.

The engine fuel supply system consists of the following parts:

- accumulator system of fuel supply Common RAIL, including a high-pressure fuel pump, injectors, fuel accumulator under high pressure, sensors of engine working environment condition (pressure and temperature of fuel and air), electromagnetic actuating mechanisms (fuel governor, electromagnetic injection valves), electronic unit of control and communication check circuits, low-pressure pipelines, high-pressure pipelines;
- fuel fine filters;
- fuel coarse filters.

System of engine start-up is electric starter. A means of start-up facilitation under low environmental temperatures are the heating plugs.

System of air delivery consists of a turbocharger, an air pipeline and a system of charged air cooling.

The turbocharger is executed as follows: radial centripetal turbine and centrifugal single-stage compressor with cantilever arrangement of wheels in relation to supports.

The system of air purification consists of a dry-type air cleaner of “Donaldson” company with two paper filtering elements. This air cleaner has two stages of purification.

Cooling system for charged air is of a radiator type. The CAC radiator is intended for cooling the air, charged into the inlet collector.

System of engine cooling is closed-type with coolant compulsory circulation executed by a centrifugal pump. The water pump is driven by a V-belt from the crankshaft pulley. For acceleration of engine warming up after start-up and for automatic control of a temperature mode at various loadings and ambient temperatures there is a thermostat.

To provide for a required chemical composition of exhaust gases under Tier-IIIB stage the system of selective catalytic reduction (SCR) is additionally installed in the exhaust system.

The coupling clutch is frictional, dry, two-disk, spring-loaded. The CC overlays are asbestos free. The coupling control drive is mechanical.

The gearbox is 16F + 8R, mechanical, fixed-ratio, with constant-mesh gears. Shifting of gears within the ranges is executed by means of synchro-mesh units, switching between ranges is executed by toothed clutches.

The rear axle is with the main drive, differential and final drives.

Brakes: service brakes are multidisk, oil-lubricated, located on final drive pinion shafts; the parking brake is independent, manually controlled. It is possible to mount the dry-friction brakes. The trailer brake control drive can be either double-line pneumatic, or hydraulic, interlocked with tractor service brakes control. Against order the tractor may not be equipped with the trailer brake pneumatic drive – tires are inflated through a valve of the pneumatic compressor.

The rear power takeoff shaft is continuous dual-speed (540 and 1000 min⁻¹) and synchronous, the direction of rotation is clockwise when viewed from the shaft end face. There are PTO shaft end extensions: PTO shaft end extension 1 (6 splines, 540 min⁻¹), PTO shaft end extension 1c (8 splines, 540 min⁻¹), PTO shaft end extension 2 (21 splines, 1000 min⁻¹).

The transmission hydraulic system provides for the following:

- switching of the FDA drive, differential lock;
- filtration of transmission oil;
- pressure feed lubrication of gearbox bearings, of FDA drive bearings;

Steering is hydrostatic. The feed pump is gear-type, the direction of rotation is left. The dosing pump is gerotor-type. The type of the rotation mechanism - one hydraulic cylinder (L63x200) of bidirectional operation and a steering linkage.

The front driving axle has an axle drive gear, a self-locked differential, final gears (planetary gear groups). The FDA drive is a parallel-shaft gear unit with hydraulically-pressed clutch built in the gearbox, a propeller shaft. The FDA drive control is electro-hydraulic.

The lift linkage is a remote-cylinder system with a hydraulic lift, with rear left and right duplicated outlets of the hydraulic system – depending on the HHL control type.

Free drain is available at the back of the tractor for operation with hydraulic units with constant delivery, hydraulic motors for instance.

The rear lift linkage is a three-point linkage of category 2 under ISO 730 and a linkage 2 under 10677 with external locking of lower link. There are two cylinders L80x220.

Drawbar hitches of a lift type:

- short towing yoke DH 2V – for coupling with semi-trailers and semi-trailed implements;
- long towing yoke DH 3V – for coupling with trailers and trailed implements;
- pin DH-2R (“Python”) – for coupling with semi-trailers and semi-trailed machines (against order);
- towing bar DH-1M-01 –for coupling with semi-trailed and trailed agricultural machines (against order);
- cross member DH-1 – for coupling with trailed and semi-trailed machines (against order).

The cabin is a one-seated with a protective rigid framework, having thermal, noise and vibration insulation, equipped with a sprung seat adjustable for operator's height and weight, with rear-view mirrors, with a sun visor, with electrical wipers for front and rear screens, with front and rear screen washers, with a roof lamp and a place to install a radio set, with a system of heating and ventilation (upon request – additional air-conditioning). Upon request the tractor can be equipped with an additional seat. The cab doors have got locks, there are keys for the left door. Right door is for emergency exit. The cab complies with category 2 under EN 15695-1:2009.

The electrical equipment complies with GOST 3940. The rated power supply voltage for on-board network is 12V. The rated voltage for the start-up is 12V.

Instruments are a combination of devices; these are an integrated indicator; informational display; pilot lamps (glow lamps and light emitting diodes), located on the block of pilot lamps, on the control panel of the rear axle differential lock and FDA drive, on the engine control system board.

1.4 Vibration level at the operator's working place of the tractor “BELARUS-1025.5”

The vibration level at the operator's seat complies with the Council Directive 78/764/EEC. Values for the vibration level are given in the EU type approval on each type of a seat.

1.5 Noise level at the operator's working place of the tractor “BELARUS-1025.5”

Noise level at the operator's workplace conforms to Directive 2009/76/EC, Appendix 2, and does not exceed the value 86 dB (A). External noise level conforms to Directive 2009/63/EC and does not exceed the value 89 dB (A).

1.6 Tractor and its component marking

Metal nameplate is fixed at the rear of the cab on the left side, as shown in fig. 1.6.1.

Additionally the tractor serial number is applied by means of percussion on the right side member and duplicated on the right plate of the front ballast weight.

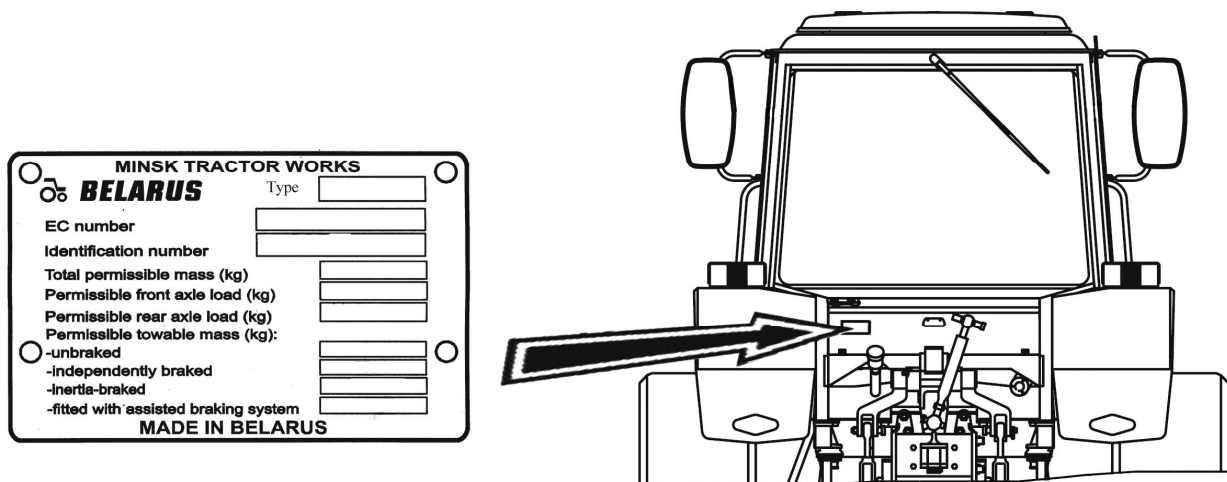

Figure 1.6.1 – Place of application the tractor nameplate

Engine number and numbers of its components are given in engine operation manual.

Numbers of tractor components are given in table 1.2

Table 1.2 – Numbers of tractor components

Number of clutch casing

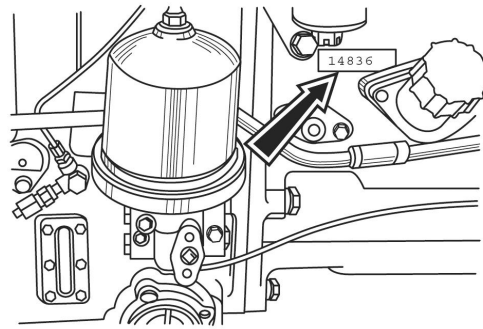

Number of gear box

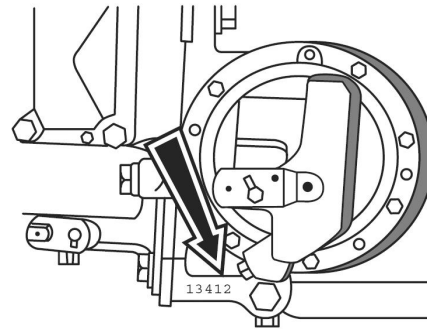

Transmission number

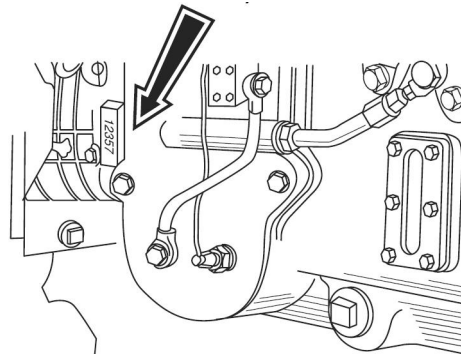

FDA number

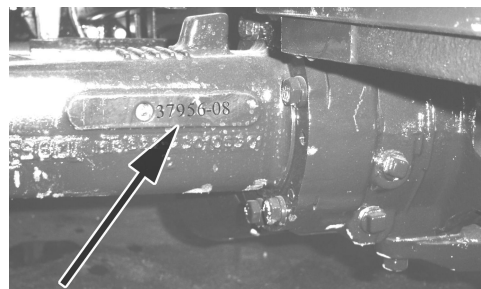

Cab serial number

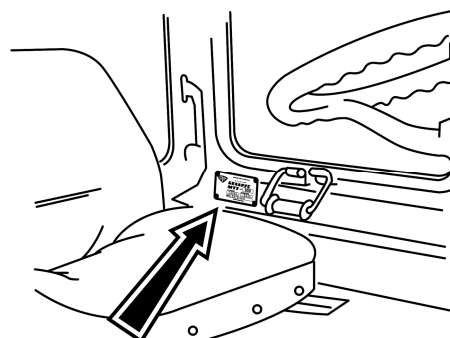

2 CONTROLS AND INSTRUMENTS

2.1 Layout of controls and instruments of the tractor

Controls and instruments, located in the tractor cab, are presented in fig. 2.1.1.

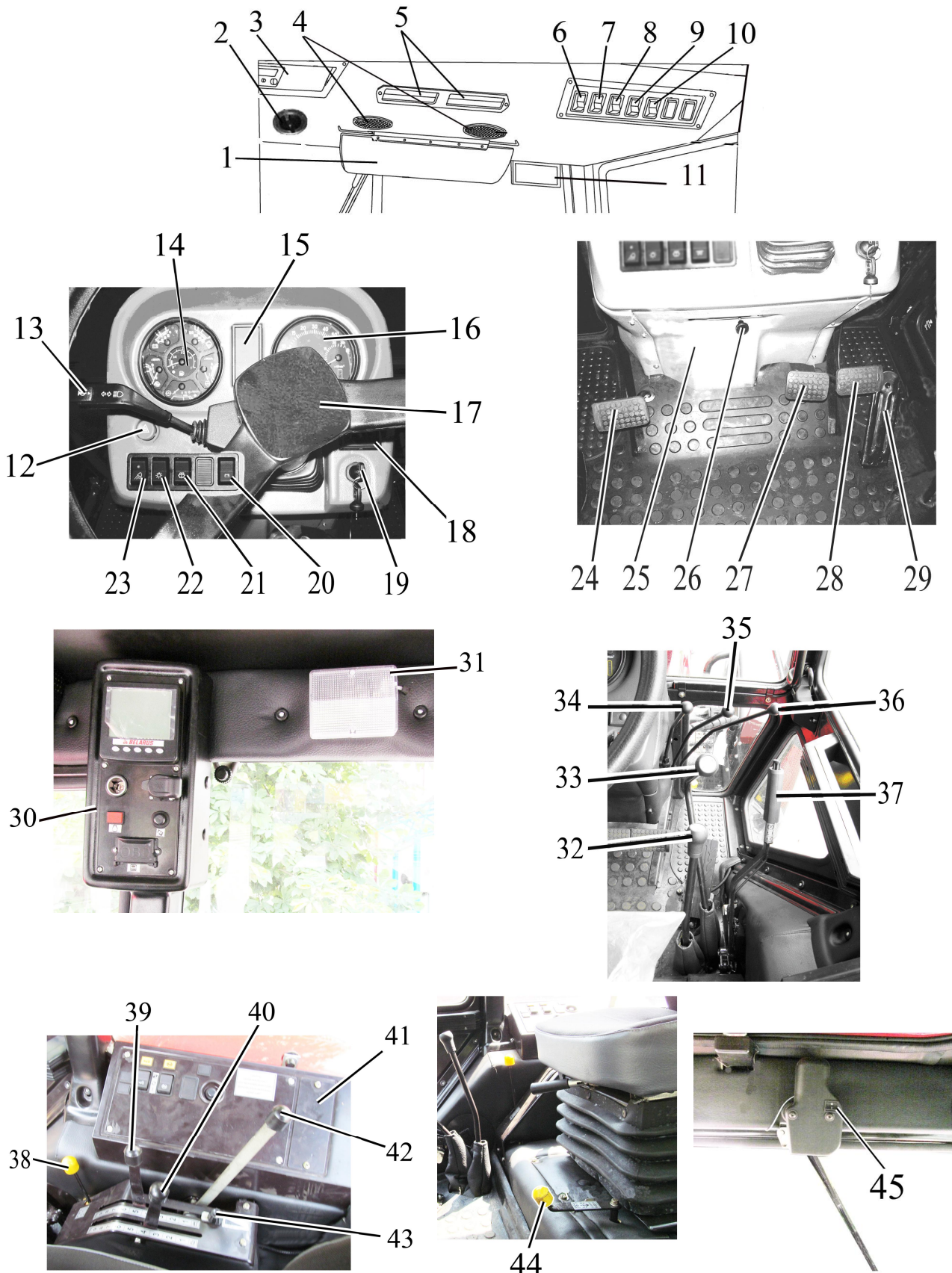
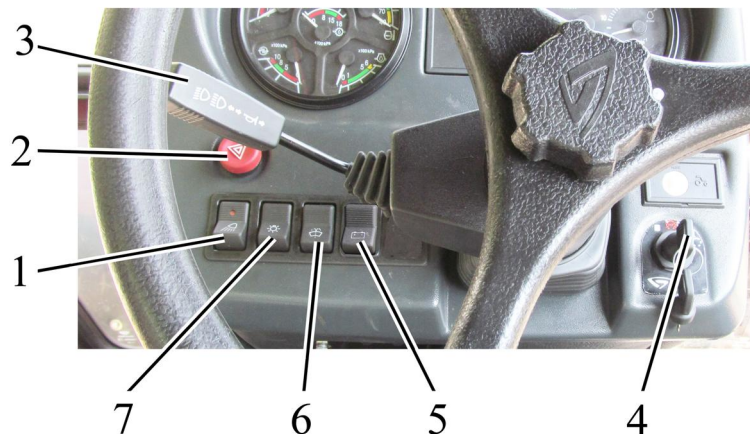

Figure 2.1.1 – Tractor controls and instruments

To the figure 2.1.1 – Layout of controls and instruments of the tractor:

1 – sun visor; 2 – handle to control the cab heater valve; 3 – place for radio receiver (car stereo) installation; 4 – deflectors; 5 – – recirculation shutters; 6 – windscreen wiper switch; 7 – cab heater fan switch; 8 – rear lights switch; 9 – switch of front lights on the cab roof; 10 – „Road-train“ light switch (design variant); 11 – rear view mirror; 12 – emergency flashing switch; 13 – multifunctional underwheel switch; 14 – instrument board; 15 – pilot lamps unit; 16 – integrated indicator; 17 – steering wheel; 18 – integrated indicator control panel; 19 – starter and instruments switch; 20 – accumulator battery remote disconnect switch; 21 – windscreen washer switch; 22 – central light switch; 23 – switch of front lights mounted on handgrips switch; 24 – clutch control pedal; 25 – front panel of dashboard; 26 – handle for steering rake tilt fixation; 27 – left brake control pedal; 28 – right brake control pedal; 29 – accelerator pedal; 30 – engine control board; 31 – cab lamp with switch; 32 – range shifting lever of gearbox; 33 – gear shifting lever of gearbox; 34,35,36 – levers to control hydrosystem outlets; 37 – parking brake control lever; 38 – rear PTO control link; 39, 40 – RLL hydrohoist control levers; 41 – console to control rear axle DL and FDA drive; 42 – handle to control fuel supply.. 43 – limiter for the position control lever; 44 – handle to switch between the ground-speed and continuous drives of PTO; 45 – rear screen wiper switch;

2.2 Switches of instrument board



1 – switch of front working lights, mounted on handgrips; 2 – emergency flashing switch; 3 – multifunctional underwheel switch; 4 – starter and instruments switch; 5 – accumulator battery remote switch; 6 – windscreen washer switch; 7 – central light switch.

Figure 2.2.1 – Switches of instrument board

The starter and instruments switch 4 (see fig. 2.2.1) has four positions:

- «0» – off;
- «I» – instruments; pilot lamps unit, heating plugs are on;
- «II» – starter is on (non-fixed position);
- «III» – radio set is on.

The layout of positions of starter and instruments disconnect switch is given in fig. 2.2.2 and in informational plate of the switch.



Figure 2.2.2 – Layout of positions of starter and instruments disconnect switch

ATTENTION: THE REPEATED SWITCH-ON OF THE STARTER IS POSSIBLE ONLY AFTER RETURN OF THE KEY INTO POSITION “0” OF THE SWITCH. TO TURN THE STARTER AND INSTRUMENTS SWITCH INTO POSITION “III” IT IS NECESSARY TO PRESS IN THE KEY WHEN IN “0” POSITION AND TURN IT CONTRACLOCKWISE!

The multifunctional underwheel switch 3 (fig 2.2.1) provides for activation of turn blinkers, switching between upper and lower beam of headlights, upper beam blinking, audible beep:

- as you move the lever of the underwheel switch 3 from or to yourself the right and the left flashers are turned on accordingly. As the tractor has made a turn the lever automatically returns to the initial position.

- the audible beep is activated by pressing the lever in axial direction. The beep can be activated in any position of the underwheel switch 3.

- as the road headlights are turned on (the button 7 is set to position “III” 2.2.1) and the lever of the underwheel switch 3 is moved down, the upper beam gets activated, and as the road headlights are on and the lever of the underwheel switch is moved up – the lower beam gets activated.

- as you move the lever of the switch 3 from the lower beam position up against the stop, the upper beam turns on for a short time (“upper beam blinking, non-fixed position) irrespective of the position of the central light switch. As you release the lever it will automatically return to the lower beam position.

Pressing the emergency flashing button 2 (fig. 2.2.1) activates the emergency flashing. A pilot lamp, built in the button, flashes simultaneously with the emergency flashing lights. Repeated pressing the button 2 deactivates the emergency flashing.

The central light switch 7 (fig.2.2.1) has three positions:

- position “I” – “off” (the upper part of the button is pressed as in fig 2.2.1);
- position “II” – “front and rear parking lights, license plate lights, lighting of instruments on the dashboard and also parking lights on a trailed machine are on” (middle position);
- position “III” – “all consumers of “II” position and road headlights are on” (lower part of the button is pressed against the stop as in fig. 2.2.1).

When pressing the button of front working lights switch 1 (fig. 2.2.1) two front working lights, located on light brackets, are actuated together with a light indicator, built in the button.

Pressing the button 6 ((Figure 2.2.1) (non-fixed position) turns the windscreen washer on. Releasing the button 6 turns the windscreen washer off.

Pressing the button (non-fixed position) of the accumulator battery remote disconnect switch 5 (fig. 2.2.1) the accumulator batteries are powered, the repeated pressing deactivates the accumulator batteries.

It is possible to activate and deactivate the accumulator battery by means of the accumulator battery manual switch 2 (figure 2.2.3) located in the area of the accumulator battery installation. To activate and deactivate the accumulator battery it is necessary to press the button 1.

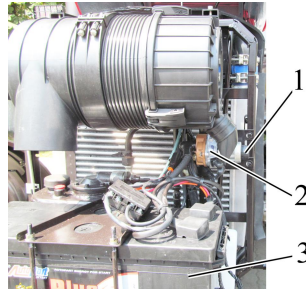

1 – button; 2 – AB manual disconnect switch; 3 – accumulator battery.

Figure 2.2.3 – Installation of the accumulator battery manual disconnect switch

2.3 Upper shield unit of button switches and rear wiper switch

Pressing the switch button 1 ((Figure 2.3.1) turns on the windscreen wiper.

The switch has got three positions:

- “Off”;
- “On with low speed”;
- “On with high speed”.

Pressing the switch button 2 (Figure 2.3.1) turns on air ventilation in the cab.

The switch has three positions:

- “Off”;
- “On in the mode of low feed of air”;
- “On in the mode of large feed of air”.

More detailed information on controlling the heater fan is given below.

Pressing the switch button 3 (Figure 2.3.1) turns two rear working lights on as well as the light indicator, built into the button.

Pressing the switch button 4 (Figure 2.3.1) turns two front working lights on the cab roof on as well as the light indicator, built into the button.

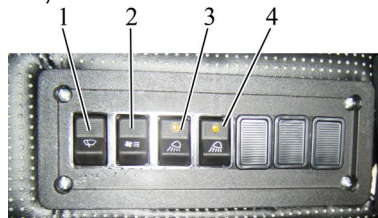

1 – windscreen wiper switch; 2 – cab heater switch; 3 – rear working lights switch; 4 – switch of front working lights on cab roof.

Figure 2.3.1 – Upper shield unit of button switches

The rear window wiper is turned on and off with a switch 1 (Figure 2.3.2).

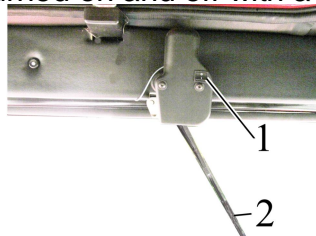

1 – switch; 2 – rear window wiper arm.

Figure 2.3.2 – Activation and deactivation of rear window wiper

2.4 Cab heater and fan control

Cab heater and fan controls are shown in Figure 2.4.1.

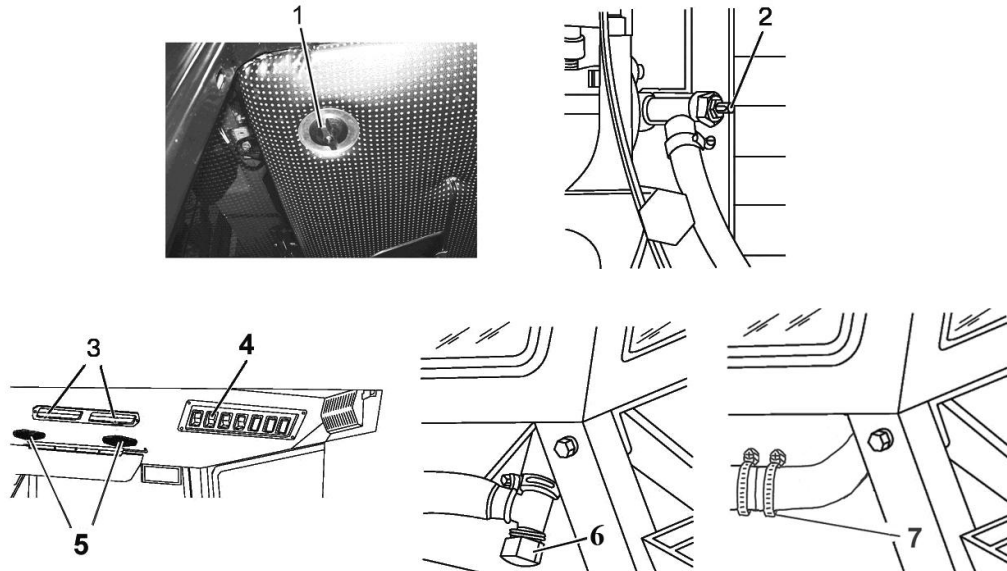

1, 2 - heater control valve handle; 3 - recirculating screen; 4 - cab fan switch control;
5 - deflector; 6 - drain plug, 7 - clamp.

Figure 2.4.1 – Cab heater and fan controls

Cab heater and fan can operate in two modes: heating and ventilation.

In order to actuate heater and fan in heating mode it is necessary to perform the following:

- after filling of cooling system start the engine and let it operate at medium rpm for warming-up of water up to the temperature from + 50°C to 60°C, then open heater control valve. To do this turn the control valve handle 1 (Fig. 2.4.1) counterclockwise up to the stop. If the heater control valve is mounted outside the cab, turn back handle 2. Increase engine rpm and in 1...2 minutes ensure that coolant is circulated through heating radiator by opening drain plug 6 of the drain valve at the right side on the cab. The heating radiator should start warming-up. In course of this level of coolant in the engine cooling system should come down.
 - refill coolant in the expansion chamber in half of the expansion chamber capacity.
 - switch the heater fan on by means of switch 4 and direct the air flow by means of deflectors 5;
 - the volume of air ventilated into the cab can be controlled by opening of recirculating screens 3;

In order to drain coolant from heating system there are drain plugs 6 at the left and right sides of a cab. After coolant has been drained blow off the system with compressed air preliminary closing a valve on cylinder block and turning off drain plugs 6. After blowing off tighten the drain plugs 6 hard.

If drain plugs 6 are not installed, so to drain the cooling fluid from the heating system the disconnection of hoses on the left and on the right side of the cab is provided. To drain the cooling fluid please do off each of clamps 7 on the left or on the right side of the cab and drain the cooling liquid into special reservoir. After the cooling liquid is drained, it is necessary to blow the system with compressed air having preliminary closed the valve on the cylinder block. After blowing please connect the hoses and tighten the clamps 7.

ATTENTION: WHEN HEATING AND VENTILATING SYSTEM IS OPERATED IN HEATING MODE CAB VENTILATION IS PERFORMED SIMULTANEOUSLY. TO OPERATE HEATING AND VENTILATING SYSTEM IN VENTILATING ONLY (DURING WARM SEASON) THE HEATER'S VALVE SHOULD BE CLOSED.

You tractor can be equipped with conditioning system instead of heating and ventilating system. Guidelines on conditioner control are presented below.

2.5 Conditioner control

2.5.1 Conditioner control in conditioning mode

The conditioner control unit has switches 1 and 2 (figure 2.5.1).

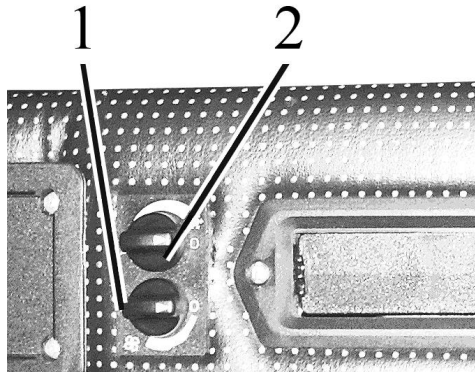

- 1 – Switch for air flow adjustment;
- 2 – Conditioner cut-out switch and cooling capacity adjustment;

Figure 2.5.1 Conditioner control unit

With the help of the switch 1 you can change air flow by changing fan speed. The switch 2 allows to change temperature of cold and dry air coming out from deflectors 4 (fig. 2.1.1) in the conditioning mode.

ATTENTION: THE AIR CONDITIONER CAN BE SWITCHED ON AND OPERATE ONLY WITH THE ENGINE ON!

To switch on the conditioner it is required to do the following:

- turn the cut-out switch 2 (figure 2.5.1) clockwise by 180° until a blue scale begins;
- then turn the switch 1 to one of three marked positions (the fan rotor has three kinds of rotation speed). After 3-5 minutes adjust a required temperature in the cab with the switch 2;
- it is possible to adjust a mixture of outer air and recirculation air with recirculation shutters 7 (figure 2.1.1) located on the upper panel;

To switch off the conditioner it is required to turn both switches 1 and 2 (figure 2.5.1) counterclockwise into “0” position.

ATTENTION: MAKE SURE THE CONDITIONER IS SWITCHED OFF BEFORE STOPPING THE ENGINE!

ATTENTION: WHEN THE CONDITIONER OPERATES IN THE COOLING MODE MAKE SURE THAT THE HEATER CONTROL VALVE IS SHUT OFF IN ORDER TO PREVENT THE SYSTEMS OF HEATING AND COOLING FROM SIMULTANEOUS OPERATION!

2.5.2 Conditioner control in a heating mode

ATTENTION: REFILLING THE ENGINE COOLING SYSTEM SHALL BE CARRIED OUT ONLY WITH LOW-FREEZING LIQUID SPECIFIED IN SUBSECTION "REFILLING AND LUBRICATION OF A TRACTOR WITH LUBRICANTS"!

To set the conditioner into the heating mode do the following:

- after refilling the cooling system with the cooling fluid start the engine and let the engine run at medium idle without opening the heater control valve to reach 70-80°C of cooling system temperature;
- then open the control valve with a handle 2 (figure 2.5.2), to do this turn the handle 2 counterclockwise against the stop;
- increase engine speed and let it run for one-two minutes until the heater radiator is filled up with the fluid. Make sure the fluid circulates through the heater. The heater radiator must warm up. Herewith the cooling fluid level in the cooling system radiator will decrease;
- refill the cooling fluid in the cooling system radiator through the filler of the expansion tank. Refill till the cooling fluid level in the expansion tank reaches 50...60 mm below the upper edge of the filler;
- to warm up the cab quickly switch on the heater fan and open recirculation shutters;

ATTENTION: WHEN OPERATING IN THE HEATING MODE THE SWITCH 2 (FIGURE 2.5.1) SHALL BE COMPLETELY OFF TO PREVENT THE COOLING SYSTEM AND THE HEATING SYSTEM FROM SIMULTANEOUS OPERATION!

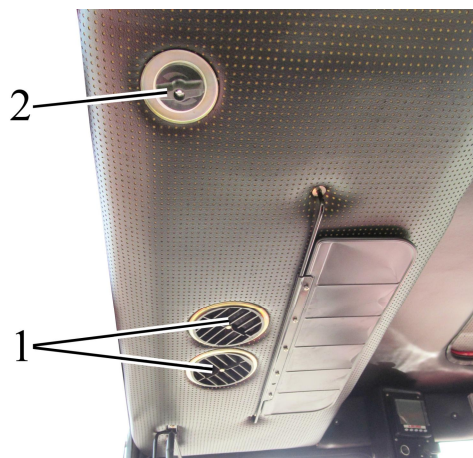

1 – deflectors, 2 – handle of heater control valve

Figure 2.5.2 – Installation of heater control valve

Note – Rules of draining the cooling fluid from the air heating and conditioning system are given in subsection 2.4 “Cab heater and fan control”.

2.5.3 Cab ventilation

During the conditioner operation in the cooling and heating modes the cab ventilation is executed simultaneously. To make the conditioner operate only in the ventilation mode it is necessary to close the heater control valve, set the switch 2 (figure 2.5.1.) in position “0” and the switch 1 in any of three marked positions.

2.6 Instrument board

The instrument board 14 (figure 2.1.1) includes six gauges with five signal lamps as shown in figure 2.6.1.

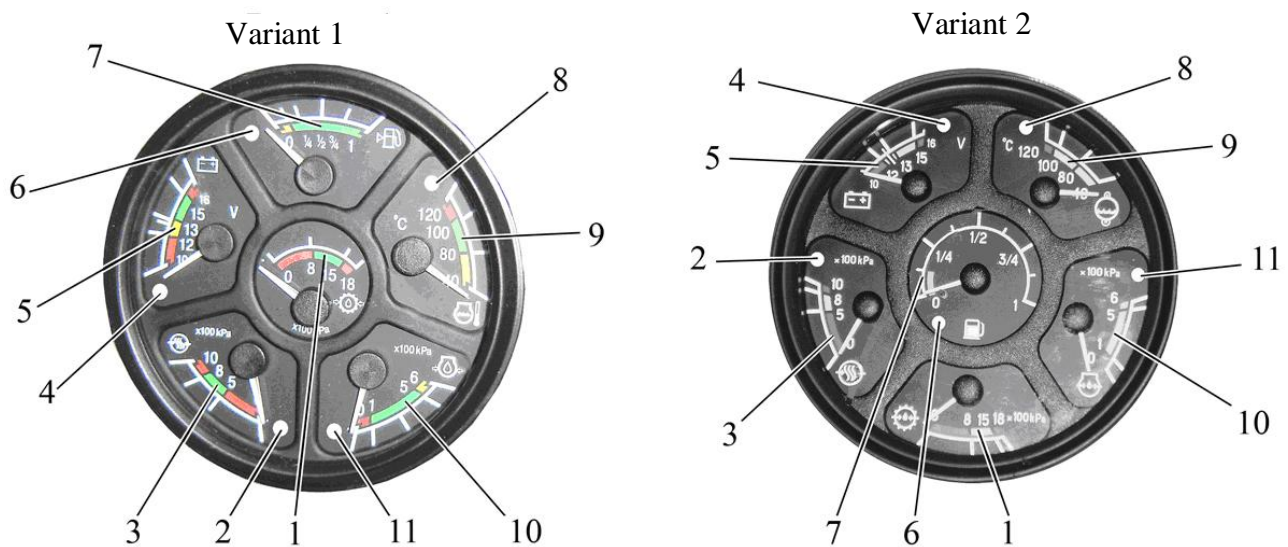

1 – gauge to indicate oil pressure in the transmission system; 2 – signal lamp of emergency air pressure in the pneumatic system; 3 – gauge to indicate air pressure in the pneumatic system; 4 – pilot lamp of additional accumulator battery (not used); 5 – voltage gauge; 6 – signal lamp of reserve fuel volume in the tank; 7 – gauge to indicate fuel volume in the tank; 8 – signal lamp of emergency temperature of engine coolant; 9 – gauge to indicate temperature of engine coolant; 10 – gauge to indicate oil pressure in the engine lubrication system; 11 – signal lamp of emergency oil pressure in the engine lubrication system;

Figure 2.6.1 – Instrument board

2.6.1 The gauge of oil pressure in the transmission hydraulic system 1 (figure 2.6.1) indicates oil pressure in the hydraulic system of friction clutches control in tractor transmission.

The scale of oil pressure gauge has three zones:

- working — from 800 to 1500 kPa (green color);
- emergency (two) — from 0 to 800 kPa and from 1500 to 1800 kPa (red color).

The normal working oil pressure in the hydraulic system of the transmission is 900 to 1100 kPa.

2.6.2 The scale of the gauge of oil pressure in the pneumatic system has three zones:

- working – from 500 to 800 kPa (green color);
- emergency (two) — from 0 to 500 kPa and from 800 to 1000 kPa (red color).

A signal lamp 2 (red color) is built in the gauge scale which lights up when the pressure in the pneumatic system drops below 500 kPa.

2.6.3 The voltage gauge 5 (figure 2.6.1) indicates accumulator batteries voltage with the engine stopped when the key of starter and instruments switch (figure 2.2.2) is set in position “I”. With the engine running the voltage gauge indicates voltage on generator terminals.

The states of the power supply system depending on the position of the gauge pointer on the scale are given in table 2.1.

Table 2.1 – The states of the power supply system

Zone on the voltage gauge scale 5 (figure 2.5.1), color	States of power supply system	
	with the engine running	with the engine stopped
13,0 – 15,0 V green	normal mode of charge	–
10,0 – 12,0 V red	the generator is out of order	accumulator battery discharged
12,0 – 13,0 V yellow	No AB charge (low charging voltage)	AB has a normal charge
15,0 – 16,0 V red	AB recharge	–
white line in the yellow zone	-	Rated AB electromotive force is 12,7 V

ATTENTION: IF THE VOLTAGE GAUGE INDICATES ABSENCE OF AB CHARGE, CHECK THE STATE AND TENSION OF THE GENERATOR DRIVE BELT!

2.6.4 The scale of the gauge indicating fuel volume in the tank 7 has the divisions “0-1/4-1/2-3/4-1”. A signal lamp 6 (orange color) is built in the gauge scale, which lights up when fuel volume in the tank drops below 1/8 of the total tank volume.

ATTENTION: DO NOT LET THE TANK BECOME EMPTY (THE GAUGE POINTER IS IN THE ZONE OF ORANGE COLOR)!

2.6.5 The gauge scale of engine coolant temperature 9 has three zones:

- working – from 80 to 105 °C (green color);
- informational – from 40 to 80 °C (yellow color);
- emergency – from 105 to 120 °C (red color);

An emergency temperature lamp (red color) 8 is built in the scale, which operates in two modes:

- lights up and operates in a flashing mode with coolant values from 109 up to and including 112 °C.
- glows in a continuous mode with coolant temperature values from 113 °C and higher.

2.6.6 The oil pressure gauge scale in the engine lubricating system 10 has three zones:

- working – from 100 to 500 kPa (green color);
- emergency (two) – 0 to 100 kPa and from 500 to 600 kPa (red color).

A signal lamp of emergency oil pressure drop 11 (red color) is built in the gauge scale, which lights up when the pressure drops below 100 kPa.

ATTENTION: WHEN THE COLD ENGINE IS STARTED THE PRESSURE CAN BE 600 kPa and HIGHER!

ATTENTION: IF THE EMERGENCY PRESSURE LAMP IS ON WITH THE ENGINE RUNNING, IMMEDIATELY STOP THE ENGINE AND ELIMINATE THE FAILURE!

2.7 Pilot lamps unit

2.7.1 General information

The pilot lamps unit 15 (figure 2.1.1) includes three lamps. The allocation scheme is presented in figure 2. 7.1.

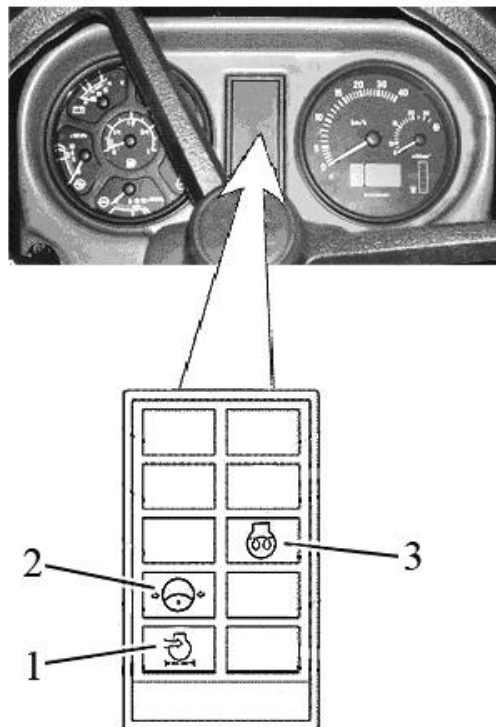

1 – pilot lamp to indicate that the air cleaner filter is clogged to the max. (orange color); 2 – pilot lamp to indicate emergency oil pressure drop in the system of hydrostatic power steering (red color); 3 – pilot lamp to indicate operation of heating plugs (orange color)

Figure 2.7.1 – Pilot lamps unit

The operating principle of the pilot lamps of CLU is the following:

- pilot lamp 1 to indicate that the air filter is clogged to the max. (figure 2.7.1) lights up when the max. permissible level of filter dirtiness is exceeded and the filter requires cleaning;
- pilot lamp 2 to indicate emergency oil pressure drop in the system of hydrostatic power steering lights up when the oil pressure in the system of hydrostatic power steering drops below 0,08 MPa (periodic lighting up of the lamp 2 with engine minimal speed is assumed – when revolutions are increased the lamp 2 shall go out);
- pilot lamp to indicate operation of heating plugs 3 indicates heating plugs operation (functioning algorithm of the pilot lamp indicating heating plugs operation is provided below).

2.7.2 Functioning algorithm of pilot lamp to indicate operation of heating plugs

As a means of start facilitation heating plugs are used in tractors "BELARUS – 1025.5", they are mounted in the cylinder head. For individual control of heating plug operation modes, indication of their operation a heating plug control unit is used.

The heating plugs are activated, if the engine temperature exceeds +5°C. Hereby a heating plug pilot lamp 3 (figure 2.7.1) lights up for 2 sec., or doesn't light up at all.

If engine temperature is below 5°C, the heating plugs are activated automatically as the key of starter and instrument switch is turned from position "0" (off) into position "I" (Instruments on). Hereby the heating plug pilot lamp 4 lights up in the pilot lamp unit of the dashboard. The heating plug operation time depends on engine temperature as per table 2.2. The engine is to be started as the lamp 4 goes out after the time, specified in table 2.2. After the engine start-up, the heating plugs remain on for some time, then they go out. The heating plug operation time after the engine start-up depends on the engine temperature at the moment of the heating plug activation. (see table 2.2).

The heating plug operation algorithm has the following emergency modes:

- as the key of starter and instrument switch is turned from position "0" (Off) into position "I" (Instruments on) the heating plug pilot lamp starts to flash continuously with 2 Hz frequency. This means that there is a failure in the heating plug operation – all heating plugs are closed-circuit or their connection is disturbed (disconnected from the heating plug control unit), the heating plug control unit is not powered or the power supply wire is damaged. Herewith, in case of short circuit the heating plug control unit cuts power supply (12V) to the heating plugs.

- after the engine start-up the heating plug pilot lamp 3 starts flashing for one minute with 3 sec. of cycle duration and 0,25 sec. of flash duration. The number of flashes can be different. The start-up procedure runs in an ordinary way. This means that one or mote (but not all) heating plugs are faulty. The number of flashes within one cycle equals to the number of faulty heating plugs;

If the specified trouble is not eliminated, it might be difficult to start the engine at low temperature.

- during the pre-start heating before engine start-up the pilot lamp 3 flashes with 1 Hz frequency. This points at short-circuit of the heating plug temperature sensor, or breakage in the heating plug temperature sensor circuit, or sensor failure. Time of engine pre-start heating as well as plug heating after engine start-up is set forth in the table 2.2

IT IS FORBIDDEN TO OPERATE THE TRACTOR UNTIL FAILURES OF THE HEATING PLUG SYSTEM ARE FOUND OUT AND ELIMINATED, AS IT MAY LEAD TO DISCHARGE OF ACCUMULATOR BATTERIES!

Table 2.2 – Heating plug operation time depending on engine temperature

Engine temperature, °C	Time of engine pre-start heating, sec.	Time of heating after engine start-up, sec.
-40	50	183
-20	33	183
0	20	74
+20	13	45
+40	9	33
+50	8,5	31
+60	0	0
sensor breakout	33	183

2.8 Integrated indicator

2.8.1 General information

The integrated indicator 16 (figure 2.1.1) (hereinafter II) and the integrated indicator control panel 18 (figure 2.1.1) (hereinafter IICP) display information on operational parameters of systems and units of the tractor and provide operator with data on violation of work or breakdown of any system.

The II includes gauges and signal lamps as per figure 2.8.1.

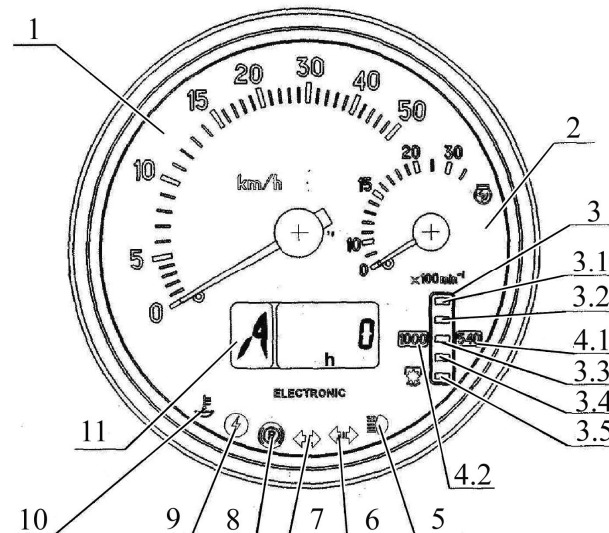

- 1 – velocity gauge (needle indicator);
- 2 – engine speed gauge (needle indicator);
- 3 – PTO speed gauge (light indicator);
- 3.1, 3.5 – segments of PTO speed scale (yellow color);
- 3.2, 3.3, 3.4 – segments of PTO speed scale (green color);
- 4.1, 4.2 – annunciator of PTO speed scale range (yellow color);
- 5 – pilot lamp to indicate headlights upper beam switching (blue color);
- 6 – pilot lamp to indicate switching of trailer turn blinkers (green color);
- 7 – pilot lamp to indicate switching of tractor turn blinkers (green color);
- 8 – pilot lamp to indicate parking brake engagement (red color);
- 9 – pilot lamp to indicate enhanced voltage in on-board system (red color);
- 10 – pilot lamp to indicate low level of coolant (yellow color);
- 11 – multifunction display.

Figure 2.8.1– Integrated indicator

2.8.2 Assignment and operation principle of integrated indicator gauges

a) Velocity gauge 1 (figure 2.8.1) indicates a design speed of the tractor on a needle indicator. The design speed exceeds the actual one, as tractor skidding is not taken into account.

The gauge is actuated by signals coming from pulse sensors of rotation frequency of toothed gears of final drives of right and left rear wheels. The speed is indicated in accordance with the signal from the sensor installed on the final drive gear of the wheel, turning with a less speed.

In case one of the speed sensors is faulty the integrated indicator shows speed readings in accordance with the signal coming from the correct sensor. Specific faults of circuits or speed sensors when the signals from them are missing are displayed in liquid crystal display as “0” digit, characterizing the fault location – to the right or to the left (see below).

b) The engine speed gauge 2 (figure 2.8.1) indicates rotation frequency of the engine crankshaft on a needle indicator.

Information on engine speed on tractor BELARUS-1025.5 comes from the electronic control unit. The range of speed readings is from 0 to 3500 (rpm).

c) PTO speed gauge 3 (figure 2.8.1) displays the PTO speed on a light indicator.

The rear PTO speed gauge is actuated by frequency signal, resulting from recalculation of engine speed by means of entered value of index "KV2" (see below), other than "0", meanwhile value of index "ZV", equal to "0", should be entered (see below).

When II is switched on (see below the description of device functional check) and engine is running (message "engine speed" from engine control unit is transmitted) identifications of scales "540" and "1000" are illuminated simultaneously.

Indication of PTO scale segment (with regard to the entered value of index "KV2") occurs when PTO rated speed, equal to 750 rpm, is achieved.

Indication of lower PTO scale segment (with regard to index "KV2") occurs when engine speed of 1400-1500 rpm and above is achieved.

Depending on selected PTO speed mode (540 or 1000) illuminated scale segments identify value of PTO speed in accordance with given table 2.3.

"PTO speed" mode of liquid-crystal display 11 of multifunctional indicator (Fig. 2.8.1) (see below the description of multifunctional display operation) is not active in this case.

Table 2.3

«540»	«1000»	Segment location on scale
650	1150	3.1
580	1050	3.2
500	950	3.3
420	850	3.4
320	750	3.5

d) The multifunctional display 11 (figure 2.8.1) is a liquid-crystal display that shows information in two fields simultaneously (figure 2.8.3):



1 – digital identification of gear box switch position (digits from 0 to 6) or letter identification of reduction unit switch position (letters L, M, H, N);

2 – current numeric value of one of tractor system parameters.

Figure 2.8.2 – Information fields of the multifunctional display

Integrated indicator receives information on gear box switch position from transmission control module (if combined electronic control system (CECS) is available) or from range reduction unit control module (if available). This parameter is displayed in information field "1" (Fig. 2.8.2). If control modules are not available or are not connected or wire is broken, letter "A" is displayed in the information field "1".

The following parameters are displayed in the information field 2 (figure 2.8.2):

- total elapsed engine time;
- instant fuel flow;
- on-board voltage;
- remaining fuel volume;
- time of running with remaining fuel;
- engine operating time for a selected period;
- testing workability of speed sensors;
- testing workability of frequency fuel volume sensor (FFVS);
- testing workability and connection of CAN-bus to the Integrated Indicator.

Switching between indication modes of “Total elapsed engine time”, “Instant fuel flow”, “Remaining fuel volume”, “Time of running with remaining fuel”, “On-board voltage”, “Engine operation time for selected period”, and switching between messages on faults are effected with “Mode” button of the control panel 18 (figure 2.1.1). Description of mode operation algorithms, “Testing workability of speed sensors”, “Testing workability of frequency fuel volume sensor (FFVS)”, “testing workability and connection of CAN-bus to the Integrated Indicator” is given below.

1. Total elapsed engine time, h

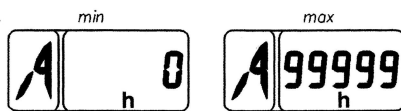

The counter accumulates information on the total elapsed engine time with uploading a message “engine speed” from the engine control unit and stores it when the power supply is off. The range of engine time indications is from 0 to 99999 hours.

tions is from 0 to 99999 hours.

2. Instant fuel flow, l/h

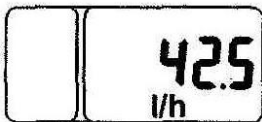

In this mode a current value of the instant fuel flow with a resolution of 0,1 l/h is displayed.

3. On-board voltage, V



In this mode a current value of on-board voltage with an accuracy of 0,1 V is displayed in a digital form.

4. Remaining fuel volume in the tank, l

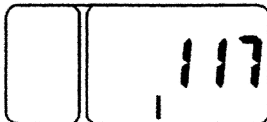

In this mode a current fuel volume remaining in the tank is displayed in liters.

This mode is available only when the tractor is stopped (i.e. when there are no signals from the speed sensors).

Note: Tractor should be stopped on horizontal surface in order to increase displaying accuracy of fuel amount in tank.

5. Time of running on remaining fuel, h

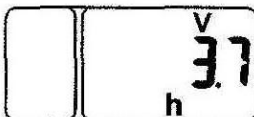

In this mode assessed engine time, calculated for current values of the instant fuel flow and remaining fuel volume is displayed, (indication increment is 0.1 hour).

6. Engine operation time for selected period

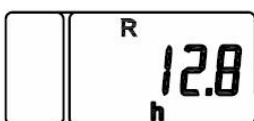

In this mode engine operation time with 1/10-of-an-hour accuracy for a selected period of operation is displayed. If required it is possible to zero the counter value by way of pressing the “Mode” button and keeping it pressed for at least 2 sec.

II in the mode of failure messages displaying

1. Testing workability and connection of speed sensors:

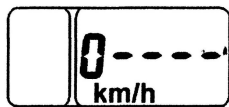

left wheel sensor

In case there are no signals coming from the speed sensor for 10-12 sec. a message in the form of "0" digit is displayed on liquid-crystal display characterizing the location of the faulty sensor (left or right)

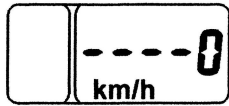

right wheel sensor

2. Testing workability of the frequency fuel volume sensor:



If there is no signal coming from the frequency fuel volume sensor for two sec. a message "FUEL" is displayed on the screen.

3. Testing workability and connection of CAN-bus to the Integrated Indicator with CAN-interface:

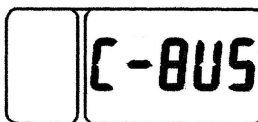

If there are no signals through CAN-bus of the integrated indicator a message "C-BUS" appears on the screen.

Each of the fault messages (**Example:** 0---, FUEL, C-BUS) is displayed in priority on the LCD-display irrespective of the information currently displayed. With sequential pushing the "Mode" button of the integrated indicator control module the messages shall be listed in turn. After the last message has been viewed and the "Mode" button has been repeatedly pressed the LCD- display changes into displaying the cyclic mode of the operating parameters specified before.

The fault messages are displayed on the LCD-screen every time the device is actuated until the cause is eliminated.

When the integrated indicator is powered-on the multifunctional display shows information in the indication mode which has been chosen before the moment of powering off the integrated indicator.

If there is no information on parameter values, which are received from ECU only, corresponding indication modes switch off automatically.

2.8.3 Pilot lamps of the integrated indicator

ATTENTION: PILOT SIGNALLING LAMS ARE ACTIVATED AND DEACTIVATED SYNCHRONOUSLY WITH CHANGING THE STATE OF SYSTEM SENSORS!

a) 5 (figure 2.8.1) - pilot lamp to indicate switching on the road lights upper beam lights up when switching on the upper beam;

b) 6, 7 (Figure 2.8.1) - indicators of tractor turns and trailer turns operate in a flashing mode when actuated with the underwheel multifunctional switch 10 (figure 2.8.1) or when the emergency button is pushed in;

c) 8 (Figure 2.8.1) pilot lamp to indicate the parking brake is enabled. 14 The pilot lamp "Parking brake" operates in a flashing mode with 1 Hz frequency when the parking brake sensor goes off;

d) 9 (Figure 2.8.1) –pilot lamp to indicate increased on-board voltage gets activated when the tractor on-board supply voltage goes up above 19V and goes out when the voltage falls below 17V;

In this case II switches off completely, and recovers its operational capability when the voltage goes down to rated value of on-board system voltage.

e) 10 (Figure 2.8.1) – pilot lamp to indicate low level of coolant (is not used).

2.8.4 Description of testing the indicator performance

Each time the power supply is on, performance testing of needle pointers and scale elements of the PTO indicator is carried out in the integrated indicator. Herewith the indicator needle pointers move away from initial marks and run over the first following digitized scale marks (over “5” for the speed and over “10” for revolutions), and all segments and indications “540” and “1000” of PTO scale are activated.

2.8.5 Programming panel of integrated indicator

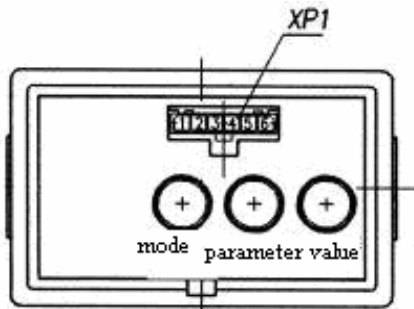

The programming panel 18 (figure 2.1.1) makes it possible to perform manual programming of the indicator by means of “Parameter” and “Value” buttons (figure 2.8.3) and to change the mode of displaying the parameters to be shown on the LCD.

Note - A diagnostic connector XP1, located on the front surface of the control panel, makes it possible to perform automatic programming (reprogramming) of the integrated indicator (II) by means of a special device (if provided). Should such a device be unavailable, the programming

shall be performed by means of the above mentioned buttons. On “BELARUS-1025.5” tractors, the XP1 connector is not enabled.

Figure 2.8.3 – Programming panel of integrated indicator

Algorithm of integrated indicator programming

1. When selecting a fixed value of programming parameter:

1.1 When the “Parameter” button is pressed for the first time (see Figure 2.8.3), the LCD switches to the mode of viewing the programmed parameter and its numerical value. When the button is pressed repeatedly, the parameters are alternated cyclically.

1.2 When the “Value” button is pressed repeatedly (see Figure 2.8.3), the numerical value of the set programmed parameter is changed.

1.3 When neither the “Parameter” nor “Value” button is pressed for 7.0 seconds, the mode is exited automatically.

When exiting the mode, the parameter values selected with the “Value” button are stored.

2. When inputting an unfixed value of programming parameter:

2.1 Press the “Parameter” button to select the parameter the value of which is to be set;

2.2 Twice press the “Mode” button, the low-order digit on the LCD screen will start blinking;

2.3 To change the blinking digit of the parameter, press the “Value” button;

2.4 To select the high-order digit, press the “Parameter” button;

2.5 To exit the programming mode of an unfixed value of any parameter, press the “Mode” button twice;

2.6 After the said mode is exited, the digits of the input value of the parameter stop blinking.

2.7 The newly set value is put the last in the list of allowed ones for programming the parameter values;

Notes:

- when the “Mode” button is pressed once in the programming mode, input of an arbitrary parameter value is not possible;

- when none of the “Mode”, “Parameter”, “Value” buttons is pressed for seven seconds in the mode of unfixed value input, the ID automatically switches to the main LCD mode, and all set parameter values are stored.

One unfixed value can be input in a range:

- for "Z" - 23 to 69;
- for "I" - 1,000 to 4,000;
- for "R" - 400 to 1000;
- for "K" - 2,360 to 4,000; (For an ID without a CAN interface)
- for "KV2" - 0.346 to 0.600;
- for "ZV" - 12 to 78;
- for "V" - 0 to 600;

List of programmed ratios (graphic examples of parameter presentations and their values in the programming mode):

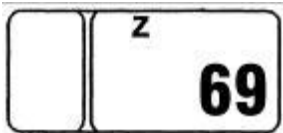

"Z" parameter

Z is the number of teeth of final shaft gears of the driving wheels (right and left), over which the travel speed (rotation speed) sensors are installed.



"I" parameter

I is the gear ratio multiplier of the wheel-hub drive.

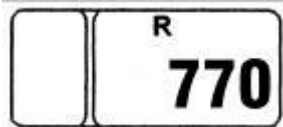

"K" parameter

R is the rear axle rolling radius, mm. When reprogramming, this parameter can be modified with a 5 mm step.

Note 770 is the value for tires 18.4R34. If other tire types are installed, set the "R" value corresponding to the rolling radius of the installed tires.



"KV2" parameter

KV2 is the PTO gear ratio.

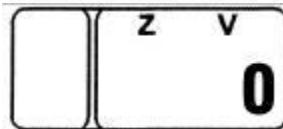

"ZV" parameter

ZV is the teeth number of the PTO speed sensor gear (Note – if a sensor is not installed, input "0").

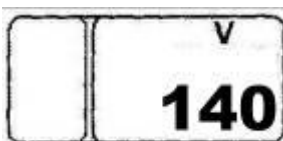

"V" parameter

V is the fuel tank volume, l.

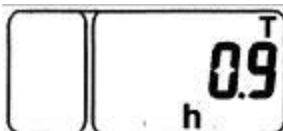

Also, when the "Parameter" button is pressed in the programming mode, the list of programmed parameters contains an independent "T" parameter of precise readout of the astronomic service hours of the engine. This parameter cannot be modified, it is the precise number (to 1/10 of hour) of engine service hours.

During operation, it is allowed to modify the failure of the parameter of wheel rolling radius "R", which is determined based on the tires installed on the tractor by measuring the distance from the wheel center to the reference surface.

DO NOT MODIFY THE ENTERED VALUES OF ALL OTHER PARAMETERS (FACTORY DEFAULTS).

When the instrument scale illumination is on, i.e. when the central light switch 22 (Figure 1.1) is switched to the position II "Instrument panel illumination, clearance lamps ON" and to the position III "Consumers of the position II and front headlights ON", the brightness of the display of the PTO indicator segments is automatically reduced.

2.9 Engine control panel

2.9.1 General information

The engine control panel 5 (Figure 2.9.1) includes a button switch of testing activation 1, a fault testing annunciator 2, a cigarette lighter 3, an information display 4, electrical receptacle 12V/25A 6, testing jack 7.

The button switch of testing activation 1 is intended to call up active errors from the memory of the engine electronic control unit by means of light codes, displayed by the fault testing annunciator 2. This way of testing is alternative in comparison with information display 4. Regarding reading and decoding light errors as well as fault elimination refer to the engine operation manual, attached to your tractor. The eliminated errors are to be eliminated. To eliminate the detected faults, please, contact your dealer.

After the key of the starter and instrument switch is turned from the position "Off" into the position "Instruments are on", the system is powered. After the system has been powered it carries out a self-check. If there are no errors in the operation of the system the fault testing annunciator 2 on the panel of engine control system shall turn on and go out, thus testifying of workability of the annunciator 2 lamp and its correct connection to the tractor on-board system.

A special testing jack 7 is intended for connection of system testing devices to carry out an extended service diagnostics of the engine under operation. The named system testing devices are recommended for dealer centers.

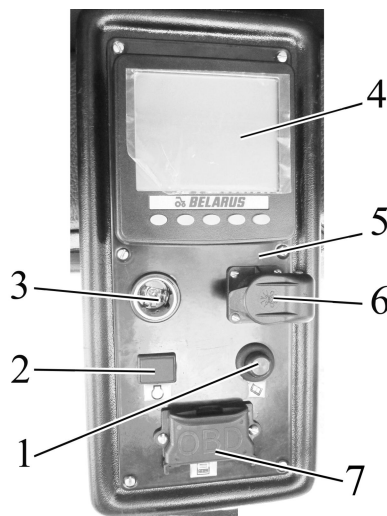

1 – button switch of testing activation; 2 – fault testing annunciator; 3 – cigarette lighter; 4 – information display; 5 – engine control panel; 6 – electrical receptacle 12 V/25 A; 7 – testing jack.

Figure 2.9.1 – Panel of engine control system

2.9.2 Information display

2.9.2.1 General information

The information display 4 (figure 2.9.1) is designed to display engine actual parameters and indication of the engine electronic control system (EECS) faults.

When the key of starter and instrument switch is set into "I" position supply voltage is delivered to the engine electronic control system. After the supply voltage is delivered the EECS constantly performs self-testing. If there are no faults in the EECS operation, the

information display functions in a working mode – it displays actual parameters of engine operation.

When the error is defined, the information display produces an acoustic signal and a brief description of the identified errors appears on the screen, also a fault testing annunciator lights up or flashes on the engine control panel 5. Interpretation of error codes as well as recommended actions to be taken to eliminate the identified faults are given in the engine operation book attached to your tractor.

ATTENTION: THE ERRORS IDENTIFIED ARE TO BE ELIMINATED! TO ELIMATE THE ERRORS CONTACT YOUR DEALER!

2.9.2.2 Adjustment of brightness and sharpness of the information display

To enter the mode of adjustment of screen brightness and sharpness 7 (figure 2.9.2) press button 5. In the screen lower part images of buttons are given. Pressing button 1 decreases brightness, pressing button 2 increases brightness, pressing button 3 decreases sharpness, pressing button 4 increases sharpness, and pressing buttons 1,2,3,4 simultaneously adjusts to an average value of sharpness and max. brightness. Repeated pressing button 5 exits the mode of brightness and sharpness adjustment.



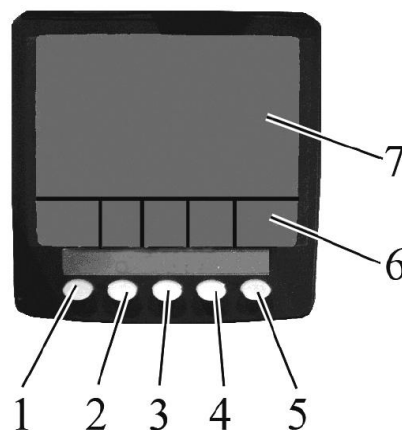











2.9.2.3 Call up of changeable images and parameters on the screen of the information display



1 – button to activate the main (three-segment) image and choose between displayed parameters; 2 – button to activate four-section image and choose between displayed parameters; 3 – button to activate graphic display and choose between displayed parameters; 4 – button to activate indication of error (fault) list and choose between displayed parameters; 5 – button to enter/exit the mode of adjustment of sharpness, brightness and configuration menu; 6 – changeable display of buttons functional purpose; 7 – screen.

Figure 2.9.2 – Information display

Table 2.4 – Lift of parameters of four-segment and graphic indication of engine operation

Parameters	Four-segment imaging	Graphic imaging	Symbol
Electric voltage directly on terminals of information monitor connection, V	✓	✓	
Voltage on the terminals of the accumulator battery, measured by the engine electronic control unit, V	✓	✓	
Fuel flow	✓	✓	
Engine oil temperature	✓	✓	
Fuel temperature	✓		
Inlet air pressure	✓	✓	
Engine oil pressure	✓	✓	
Temperature of coolant in the engine	✓	✓	
Air temperature at the inlet pipe	✓	✓	
Accelerator position, %	✓		
Use of turning torque, rpm	✓		
Engine speed, rpm	✓	✓	
Urea level in the tank, %	✓		
Urea temperature in the tank	✓		
Temperature of exhausts before the SCR catalyst	✓		

The monitor buttons 1, 2, 3, 4, 5 (figure 2.9.2) are of multifunctional purpose. When pushing any of the buttons 2, 3, 4 during the monitor operation, an image of the button panel 6 appears on the screen, the icons denoting the current functions of each button. Pressing the button 1 on the monitor activates the main three-segment image on the screen. Hereby an engine speed scale is displayed in the upper left corner, and a scale of oil pressure in the engine lubrication system in the upper right corner, cooling fluid temperature in the lower right corner, current fuel flow per hour in the lower left corner. When the three-segment imaging is indicated the displayed parameters in the lower left corner are chosen between with the button 1. To exit the mode of choosing between the displayed parameters in the upper right corner it is required to press button 5 after activation of the button panel 6. After that the parameters are chosen between with the buttons 1 and 2.

After the button panel 6 has been called up a four-segment imaging of parameters on the screen 7 is activated with the button 2. After the first pressing the button 2 four parameters are displayed in a digital mode on the screen:

- in the upper left corner – engine speed;
- in the upper right corner – coolant temperature;
- in the lower left corner – on-board voltage;
- in the lower right corner – oil pressure in the lubrication system.

When pressing the button 2 for the second and the third time, four parameters are displayed on the screen in an analog form.

Using the mode of choosing between displayed parameters the customer can activate, if necessary, displaying of various engine parameters on the screen as per table 2.4. The mode of parameter choosing is activated after calling up of the button panel with short-time pressing the button 5. Sequential pressing the button 1 changes the parameters displayed in the upper left corner, pressing the button 2 changes the parameters in the upper right corner, button 3 – in the lower left corner, button 4 – in the lower right corner. The parameter choosing mode is exited with short-time pressing the button 5.

As the button panel has been called up pressing the button 3 activates graphical displaying of parameters in the course of time (functions as parameter analogue recorder).

The required parameters are chosen with a sequential pressing the button 3 as per table 2.4.

A temporary net can be adjusted in a configuration menu from 2, 10 or 30 min. to 1, 2, 4 or 8 hours. To enter the configuration menu it is necessary to press the button 5 for more than 3 sec. Also it is possible to choose metric and British units of measurement in this menu, among available languages it is possible to choose English, Spanish, Swedish, French, German, Italian, Dutch, Portuguese and Russian.

ATTENTION: ONLY DEALERS ARE AUTHORIZED TO CHANGE SETTINGS OF CONFIGURATION MENU!

When errors (faults) are detected during operation the monitor produces a sound signal and a rhombic flashing window with an exclamation mark appears on the screen.

After the button panel has been called up a list of active errors (faults) is invoked with the button 4. Moving over the list is carried out with the button 1 and 2.

To exit displaying of the list of active errors it is necessary to confirm reception of all errors by pressing the button 3. After the errors stop to come into the display they are automatically deleted from the list.

2.10 Steering

2.10.1 General information

“BELARUS-1025.5” tractors are equipped with hydrostatic steering control (HSC). When the engine is stopped the HSC feed pump, driven by the engine crankshaft, does not feed the hydraulic system of the HSC and it is automatically shifted to a manual mode, which requires application of a greater effort on the steering wheel in order to turn the tractor.

2.10.2 Steering wheel adjustments

The steering wheel has the following adjustments:

- horizon tilt angle adjustment;
- height adjustment, along steering shaft axis.

To change height positioning of the steering wheel proceed as follows:

- unscrew the chuck 2 (figure 2.10.1) by 3-5 revolutions;
- set the wheel 1 to a position comfortable for work;
- screw in the chuck 2 with max. possible force of hand fingers.

The range of the steering wheel height adjustment is 100 mm, stepless.

To change the steering column tilt angle do the following:

- pull the handle 3.
- tilt the steering column to reach the position comfortable for work and releasing the handle 3 swing the steering column smoothly in longitudinal direction until fixed firmly.

The steering column can be tilted and fixed in four positions from 25° to 40° with 5° interval.

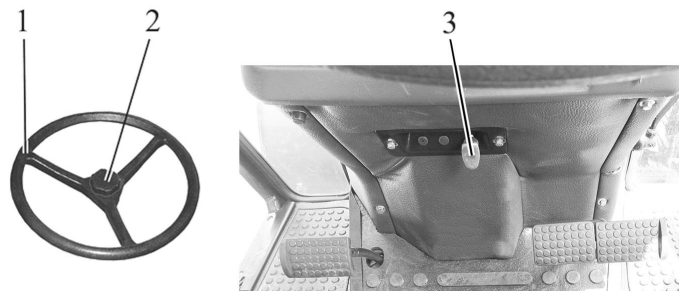

1 – steering wheel; 2 – chuck; 3 – handle to fix tilt of the steering column.

Figure 2.10.1 Steering wheel adjustment

2.11 Parking brake control

Upper position of the lever 37 (figure 2.1.1) – parking brake “On”;

Lower position of the lever 37 – parking brake “Off”.

To disengage the parking brake press the control lever button and let the lever 37 down against the stop.

2.12 Handle for fuel feed manual control

When the handle 42 (figure 2.1.1) is moved to the extreme front position, fuel is fed to the max, when the handle is moved to the extreme rear position – fuel is fed to the min. in accordance with the minimum idle speed.

2.13 Tractor pedals

2.13.1 Pressing the pedal 24 (figure 2.1.1) disengages the clutch.

2.13.2 Pressing the pedal 27 (figure 2.1.1) brakes the rear left wheel.

2.13.3 Pressing the pedal 28 (figure 2.1.1) brakes the rear right wheel. A joint plate of the brake pedals is intended for simultaneous braking with the right and left brakes.

2.13.4 Pressing the pedal 29 (figure 2.1.1) increases the engine speed.

2.14 Switching of ranges and gears of gearbox

2.14.1 General information

The gearbox is controlled with two levers: a range shifting lever 1 (Figure 2.14.1) and a gear shifting lever 3.

Select the required ranges and gears in accordance with shifting diagrams 2 and 4 as shown in figure 2.14.1.

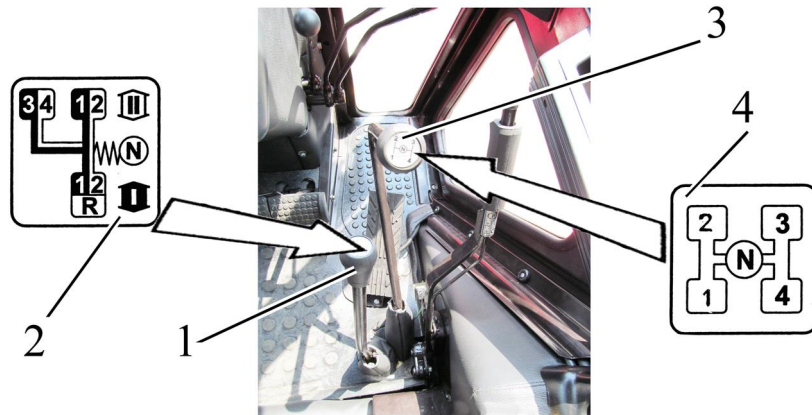

1 – lever to switch between ranges of gearbox; 2 – range shifting diagram; 3 – lever to switch between gears of gearbox; 4 – gear shifting diagram.

Figure 2.14.1 – Gearbox control

2.14.2 Tractor velocity diagram

The table of “BELARUS-1025.5” tractor velocity diagram on tyres of basic configuration is attached to the cab right window and is shown on figure 2.14.2.

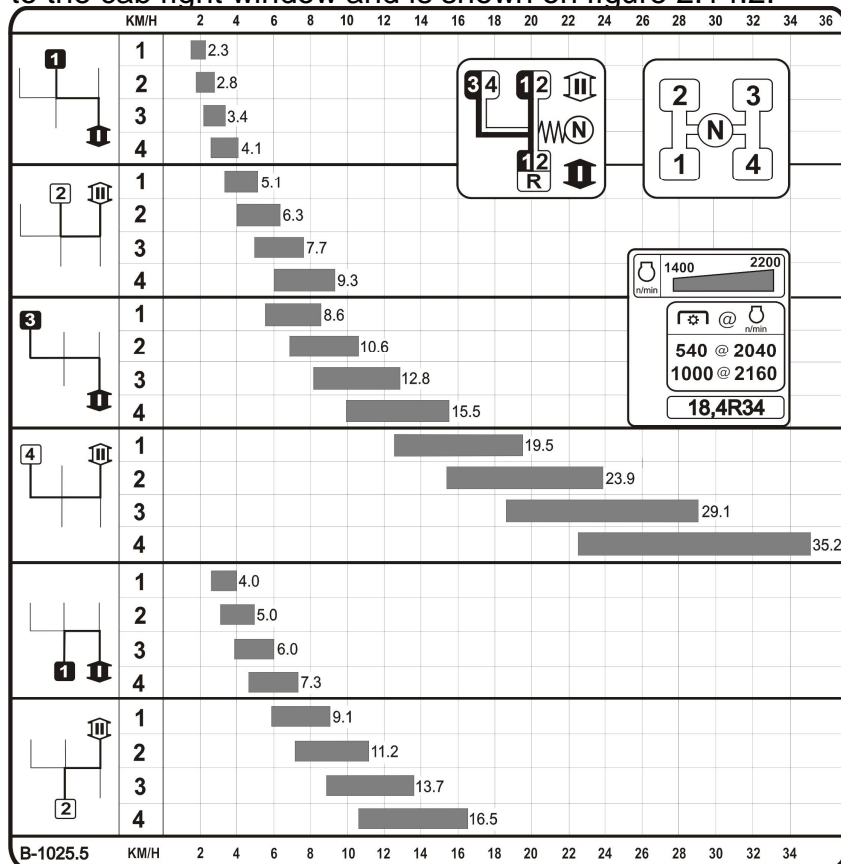
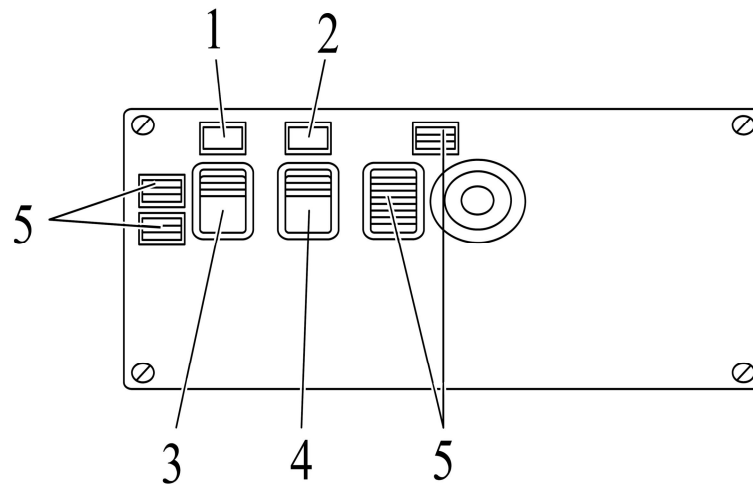

Figure 2.14.2 – “BELARUS-1025.5” tractor velocity diagram

2.15 Control panel for rear axle DL, FDA drive.

2.15.1 General information

Elements of control panel of rear axle DL, FDA drive are introduced in figure 2.15.1.



1 – FDA drive pilot lamp; 2 – rear axle DL pilot lamp; 3 – FDA drive control switch; 4 – rear axle DL control switch; 5 – blind plugs.

Figure 2.15.1 – Control panel for rear axle DL and FDA drive

2.15.2 Rear axle DL control

DL control is carried out by three-position switch 4 (Figure 2.15.1):

- “DL off” – middle fixed position. This position is used during hauling operations on hard-surface roads;
- “DL is automatically engaged” by pressing the upper part of switch 4. Fixed position. This position is used during operations with significant slipping of rear wheels. In the automated mode differential is locked during direct motion, and it is unlocked if wheels are turned through 13° to either side. When left and/or right brake pedal is pressed the differential is unlocked;
- “DL is positively activated” – by pressing the lower part of switch 4. Unfixed position. This position is used for short-term locking of differential during passage of obstacles. When switch is pressed and held in the lower position, differential is locked. When switch is released it comes back to the middle position and differential gets unlocked.

When DL is engaged, indicating lamp 2 lights up, which goes out again when DL is unlocked in an automated mode and with switch 4 is set in the middle position.

ATTENTION: ENGAGE DIFFERENTIAL LOCK WHEN SIGNIFICANT SLIPPING OCCURS DURING FIELD AND HAULING OPERATIONS!

ATTENTION: DISENGAGE DL WHEN TRACTOR DRIVING SPEED EXCEEDS 13 KM/H. OTHERWISE IT WILL RESULT IN POWER TRAIN OPERATING LIFE REDUCTION AND WILL MAKE IT DIFFICULT TO DRIVE THE TRACTOR. POSITIVE LOCKING SHALL BE USED ONLY FOR A SHORT PERIOD DURING PASSAGE OF OBSTRUCTIONS IN ROAD.

2.15.3 Front driving axle (FDA) drive control

FDA is controlled by switch 3 (Figure 2.15.1), having three positions:

- "FDA off" – middle fixed position. This position is used during hauling operations on hard-surface roads;
- "FDA is automatically engaged" by pressing the upper part of switch 3. Fixed position. This position is used during operations with significant slipping of rear wheels. FDA is automatically engaged when significant slipping of rear wheels occurs;
- "FDA is positively activated" by pressing the lower part of switch 3. Fixed position. It is used for short-term locking of FDA during passage of obstacles.

When FDA is engaged, indicating lamp 1 lights up, which goes out again when FDA is disengaged in an automated mode and when switch 3 is set in the middle position.

When synchronized brake pedals are pressed, FDA is automatically engaged not depending from switch 3 position.

ATTENTION: ENGAGE FDA WHEN SIGNIFICANT SLIPPING OCCURS DURING FIELD AND HAULING OPERATIONS!

ATTENTION: DISENGAGE FDA WHEN TRACTOR DRIVING SPEED EXCEEDS 13 KM/H. OTHERWISE IT WILL RESULT IN POWER TRAIN OPERATING LIFE REDUCTION AND WILL MAKE IT DIFFICULT TO DRIVE THE TRACTOR. POSITIVE ENGAGEMENT SHALL BE USED ONLY FOR A SHORT PERIOD DURING PASSAGE OF OBSTRUCTIONS IN ROAD.

2.16 Rear power take-off shaft control

2.16.1 Lever shifting rear PTO from continuous drive to ground-speed drive

When lever 44 (Figure 2.1.1) is shifted in the far left position (along tractor movement) ground-speed drive becomes engaged, and if it is shifted in far right position – continuous drive becomes engaged, and if it is placed in the middle – “neutral” position.

ATTENTION: ENGAGE GROUND-SPEED DRIVE OF REAR PTO ONLY FROM NEUTRAL POSITION WITH THE ENGINE IS RUNNING AT LAW GEAR OF THE FIRST OR SECOND RANGES OF GB ON THE MOVING TRACTOR. OTHERWISE POWER TRAIN DAMAGES ARE POSSIBLE! SHIFT PTO GROUND-SPEED DRIVE TO A NEUTRAL POSITION IN A SIMILAR WAY!

ATTENTION: SHIFT PTO CONTINUOUS DRIVE FROM NEUTRAL POSITION ONLY WITH ENGINE SHUT DOWN! SHIFT PTO CONTINUOUS DRIVE TO A NEUTRAL POSITION IN A SIMILAR WAY!

2.16.2 Rear power take-off shaft engagement

Engagement of rear PTO is possible only when lever 44 (Figure 2.1.1) is shifted in position “ground-speed drive of rear PTO is engaged” or in position “continuous drive of rear PTO is engaged”. Rear PTO shall not operate in “neutral” position.

Rear PTO switching rod 38 (Figure 2.1.1) has two positions:

- when rod 38 is shifted from lowermost position to uppermost position, rear PTO becomes engaged;
- when rod 38 is shifted from uppermost position to lowermost position, rear PTO becomes disengaged.

It is recommended to engage and disengage rear PTO with the engine running.

2.16.3 Two-speed continuous drive of rear PTO switch

Arm 1 (Figure 2.16.1) of the continuous drive has 2 positions:

- I — 540 min⁻¹ — full shift position, counterclockwise;
- II — 1000 min⁻¹ — full shift position clockwise.

In order to select the required PTO shaft rotation speed release the bolt 2, turn arm 1 and tighten the bolt 2.

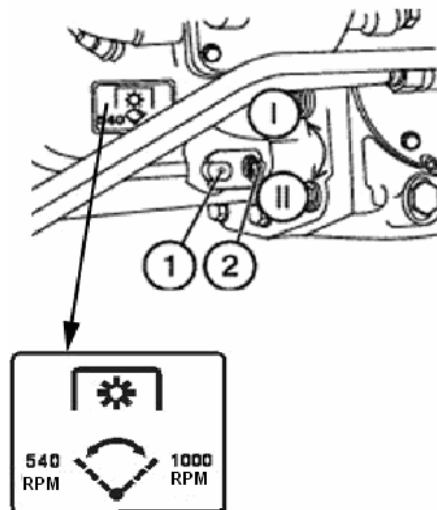

1 – arm; 2 – bolt;

Figure 2.16.1 – PTO shaft rotation speed selection

2.16.4 Tractor operation without use of rear PTO

When tractor is operated without rear PTO, the arm for shifting of continuous two-speed PTO drive must be set into position 540 min⁻¹, lever for shifting of rear PTO from continuous to ground-speed drive - must be set into “neutral” position, rod for engagement of rear PTO – must be set into position “PTO off”. Protective cap of rear PTO shaft guard must be mounted.

2.17 Rear lift linkage control

2.17.1 RLL control elements

RLL is controlled by two levers 1 and 2 (Figure 2.17.1), located in the cab on the right control console.

Draft control handle 2 is located first after operator's seat and has following positions:

- forward most position – maximum soil cultivation depth (“9”);
- rear most position – minimum soil cultivation depth (“1”).

Handle position range 2 is numbered from 1 to 9.

Position 1 control handle has the following positions:

- rear most position (“1”) – RLL transport position;
- forward most position (“9”) – minimum distance between an implement and ground.

Handle 1 position range is numbered from 1 to 9.

Maximum range of lifting of the implement by handle 1 is limited by adjustable detent 3.

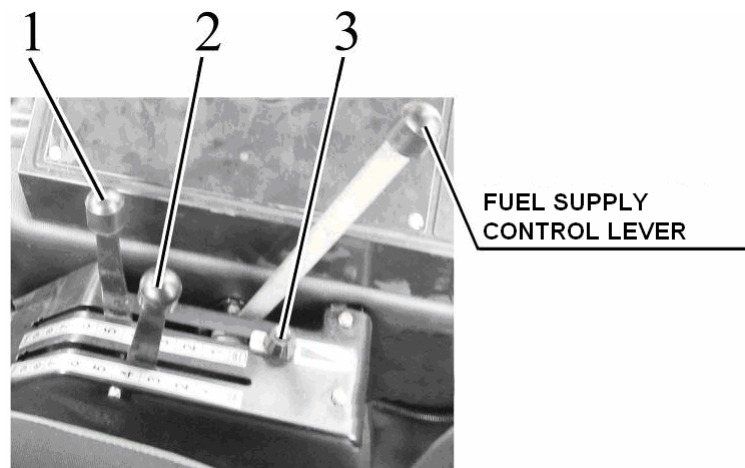

1 – position control handle; 2 – draft control handle; 3 – adjustable detent.

Figure 2.17.1 – RLL control elements

Combined control is carried out by way of implement penetration depth limiting by handle 1 during operation in the draft control mode.

2.17.2 General information about RLL control rules

Hydraulic lift linkage of your tractor is equipped with hydraulically operated lift and ensures operation of rear lift linkage in the following modes:

- lift of an attached implement and its lowering under self-weight;
- position control (automated holding of an attached implement at a specified position against the tractor);
- Draft control (adjustment of cultivation depth depending on the soil reaction);
- Combined control (adjustment of cultivation depth depending on the soil reaction with limitation of maximum depth by position control).

Position control allows accurate and sensitive control of position over the ground of an attached implement such as spraying machine, land smoother and other. Position control can be used with tillage implements on flat fields. Use of position control in the fields with an uneven surface is limited due to unavoidable vertical travel of the implement when the tractor is driven along the field undulations.

Draft control is the most appropriate mode of operation with mounted and semi-mounted implements, working attachment of which are sunk into the soil. The system is sensitive to changes of drawbar power (caused by change in soil reaction and processing depth soil) through upper link. Hydraulic system responds to these changes by lifting and lowering of an implement in order to maintain the intended drawbar power at a fixed level. The system responds to compressive force and extension force in the upper link i. e. it is double action system.

Combined control – if due to variations in soil density draft control does not allow reaching of constant processing depth, the predetermined depth should be limited by means of position control handle.

Position control shall be carried out as follows:

- set handle 2 of draft control to the forward most position in the direction of tractor travel;
- set the required height of the implement above the ground by means of handle 1 of position control.

Number “1” corresponds to transport position of RLL, and number “9” – to the minimum height of the implement above the ground. In case it is necessary to limit the maximum lifting range (for example, because of possibility of rear PTO shaft parts damage), set the maximum lifting range by handle 1 and bring an adjustable detent 3 to it.

Draft control shall be carried out as follows:

- set handle 2 of draft control to the forward most position in the direction of tractor travel (number “9” of the control desk);
- connect the implement with RLL by means of handle 1 of the position control;
- after entering the groove shift handle 1 to the forward most position and by means of handle 2 set the required soil processing depth;
- while leaving and entering the groove again (during tilling) use only handle 1 of position control, and do not touch handle 2 of the draft control.

If due to variations in soil density draft control does not allow reaching of constant processing depth, the predetermined depth should be limited by means of position control handle 1 (combined control mode), keeping in mind the corresponding number on the control desk.

When combined control is used the degree to which signals of the two sensors (force sensor and position sensor) are combined is controlled by handles 1 and 2.

ATTENTION: BEFORE LEAVING THE TRACTOR FOR ANY PERIOD OF TIME YOU MUST GROUND THE IMPLEMENT MACHINE!

2.18 HLL pump control

The HLL pump switching shaft 1 (figure 2.18.1) has two positions:

- “shaft on” – the shaft 1 is turned clockwise against the stop;
- “shaft off” – the shaft 1 is turned contraclockwise against the stop.

Before turning the shaft 1 to any of 2 two positions, loosen a bolt 2 by 1,5...2 revolutions and turn the shaft 1 together with a locking plate. Tighten the bolt 2.

The HLL pump activation diagram is given in fig. 2.18.1, as well as in the instruction shield on the lower part of the cab front wall.

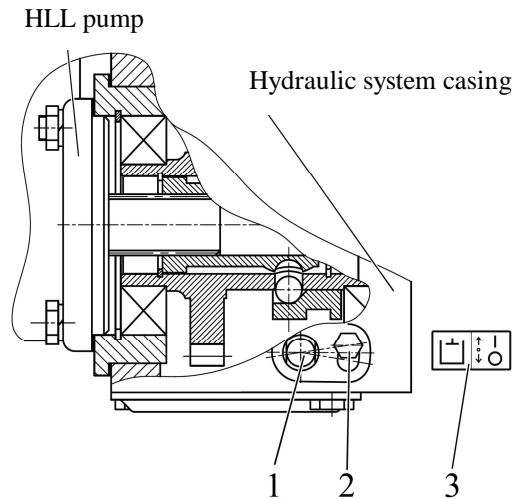

1 – HLL pump switching shaft; 2 – bolt; 3 – HLL pump activation diagram.

Figure 2.18.1 – HLL pump control

Note – The figure 2.18.1 shows the position “HLL pump on”.

ATTENTION: THE PUMP SHALL BE TURNED ON AND OFF ONLY WITH THE MIN. IDLE SPEED OF THE ENGINE!

In case failures in HLL occur that lead to oil leakage out of the hydraulic lift linkage, the pump shall be turned off when moving the tractor to repair facilities.

2.19 Hydraulic lift linkage distribution valve sections (remote cylinders) control

2.19.1 Control of remote hydraulic cylinders with distribution valve RP70-1221 or RP70-1221.1 or RS213Mita installed by means of levers.

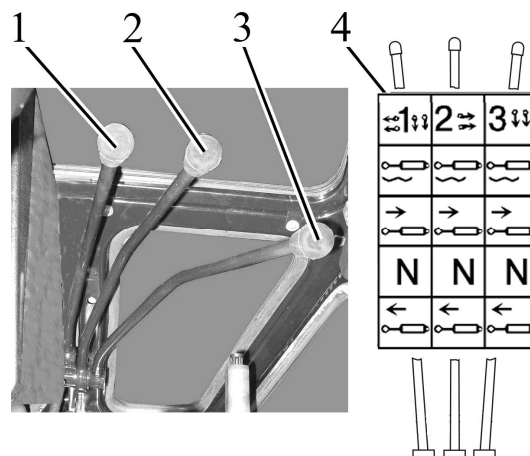

1, 2, 3, - hydraulic lift linkage distribution valve (remote cylinders) control levers; 4 - instruction plate containing distribution valve RP70-1221 or RP70-1221.1 or RS213Mita control diagram.

Figure 2.19.1: Remote hydraulic cylinders with distribution valve RP70-1221 or RP70-1221.1 or RS213Mita installed control by means of levers.

Each of the three remote hydraulic control levers 1, 2, 3 (Figure 2.19.1) of distribution valve RP70-1221 or RP70-1221.1 or RS213Mita has four positions:

"Float" – uppermost fixed position;

"Forced lowering" – middle upper non-fixed position between "Float" and "Neutral" positions. In "Forced lowering" position with the engine running the lever shall be kept in hand, because after releasing the handle it returns to "Neutral" position;

"Neutral" – bottom fixed middle position;

"Lift" – lowermost non-fixed position with distribution valve RP70-1221 or RP70-1221.1 or RS213Mita installed. In "Lift" position with the engine running the lever shall be kept in hand, because after releasing the handle it returns to "Neutral" position (in case if distribution valve RP70-1221.1 is installed, the lever 2 is fixed without automatic return into "Neutral" position. To avoid overheating of the hydraulic system and early breakdown of the pump and other units of the hydraulic lift linkage, do not forget to set the valve spool control lever into "Neutral" position after fulfillment of the operation).

Distribution valve RP70-1221 and RP70-1221.1 outputs positioning and connection to the external consumers on tractors "BELARUS-1025.5" diagram is presented on Figure 2.19.2.

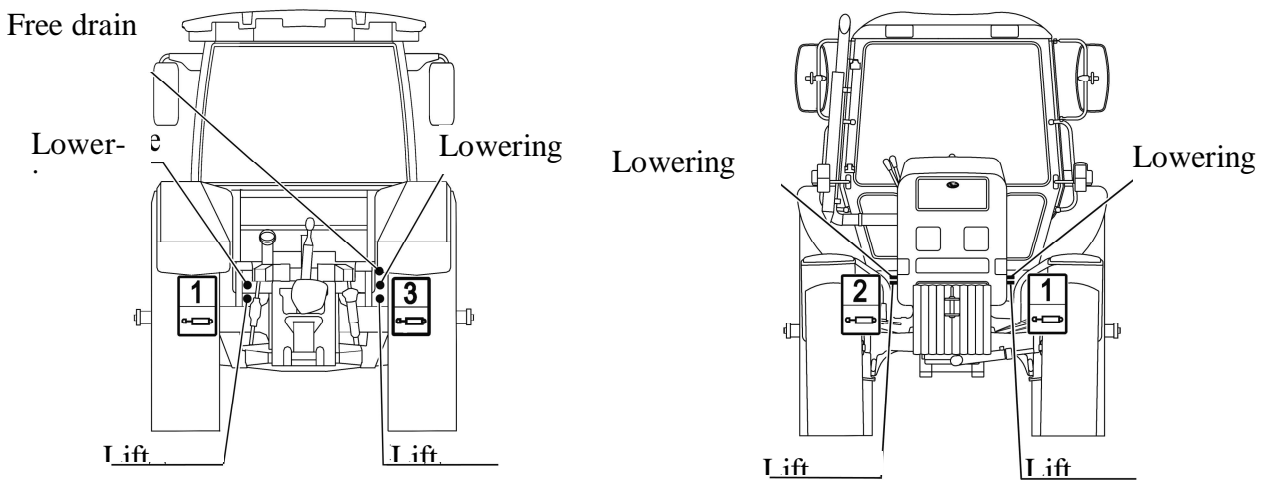

Figure 2.19.2 - Distribution valve RP70-1221 and RP70-1221.1 outputs positioning and connection to the external consumers diagram.

Distribution valve RS213Mita outputs positioning and connection to the external consumers on tractors "BELARUS-1025.5" diagram is presented on Figure 2.19.3.

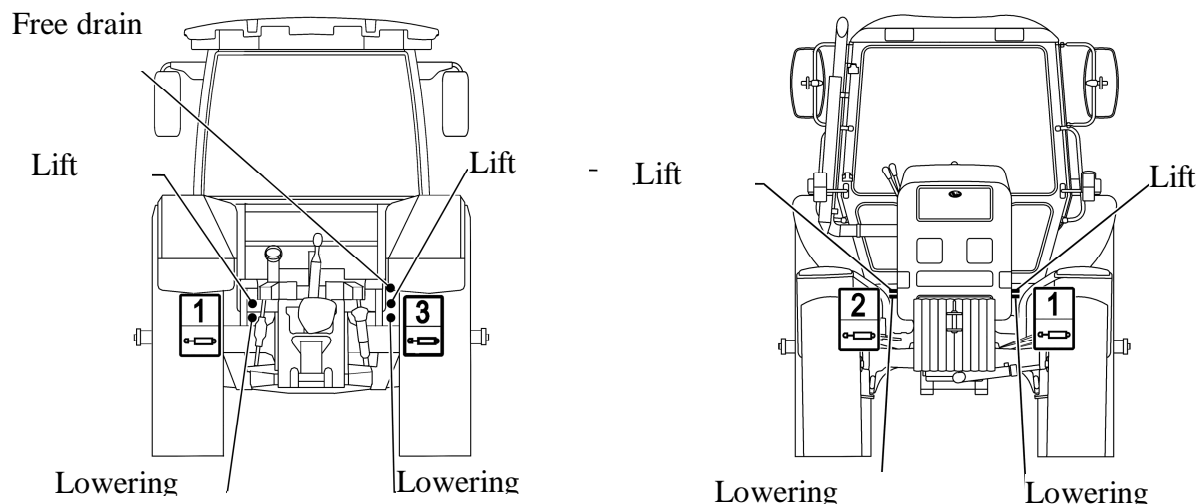

Figure 2.19.3. - Distribution valve RS213Mita outputs positioning and connection to the external consumers diagram.

2.19.2 Control of remote hydraulic cylinders with distribution valve RP70-622 or RP70-622.1 installed by means of joystick and lever

When distribution valve RP70-622 or RP70-622.1 are installed on the tractor the remote control of the distribution valve spool is possible, which is performed by means of joystick 1 (Figure 2.19.4) and lever 2 with two-way motion ropes. Joystick and lever are installed on the right control console in tractor cab instead of hydraulic system distribution valve outputs control levers.

Joystick 1 is designed for control of the two distribution valve spools (sections):

- when joystick lever 1 is moved lengthwise the spool connected to the left side hydraulic outputs is controlled.
- when joystick lever 1 is moved in cross direction the spool connected to the right side hydraulic outputs and rear right duplicated outputs is controlled.

The lever 2 may be shifted only lengthwise and is controlled by the middle spool, connected to the rear left hydraulic system outputs.

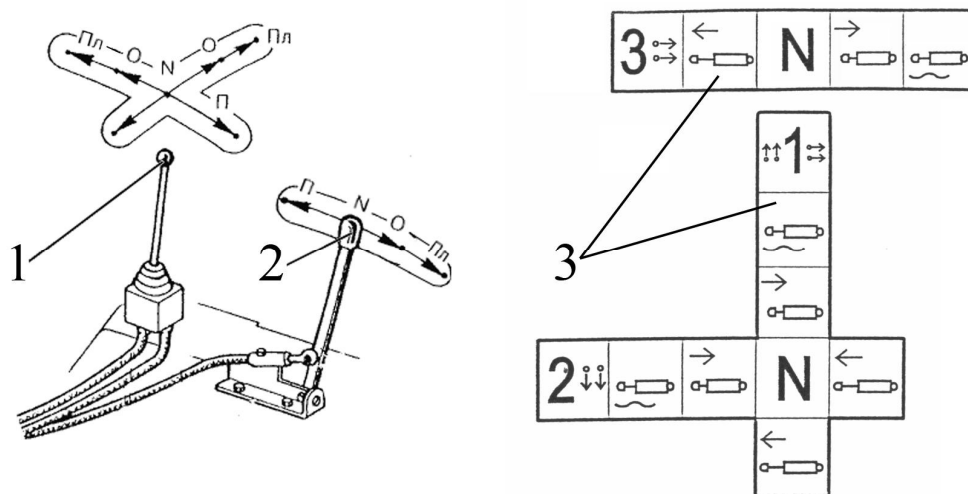

1 - joystick; 2 - lever; 3 - instruction plates for joystick and lever control.

Figure 2.19.4 Remote hydraulic cylinders with distribution valve RP70-622 or RP70-622.1 installed control by means of joystick and lever.

Distribution valve RP70-622 or RP70-622.1 outputs positioning and connection to external consumers on the tractors "BELARUS-1025.5" diagram is shown in Figure 2.19.5.

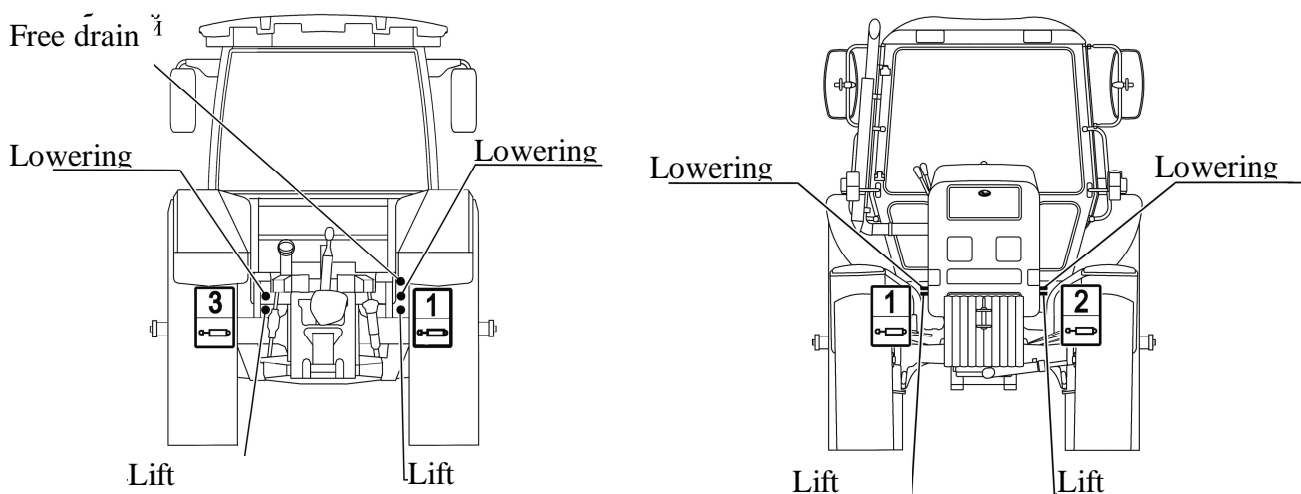

Figure 2.19.5. - Distribution valve RP70-622 or RP70-622.1 outputs positioning and connection to external consumers on the tractors "BELARUS-1025.5" diagram.

2.20 Cutout fuses

2.20.1 General information

Cutout fuses are intended for protection of electrical lines against overloads and short circuit.

WARNING: TO AVOID BURNING OF TRACTOR WIRING NEVER USE FUSES WITH CURRENT RATING HIGHER THAN RATING SPECIFIED IN THIS SECTION. IF A FUSE OFTEN BURNS OUT, FIND OUT THE CAUSE AND ELIMINATE THE FAULT!

2.20.2 Fuses for electrical equipment system

Three blocks of cutout fuses are built into the instrument board. To access the cutout fuses do two screws 2 out (Figure 2.20.1) and open the cover of the instrument board 1.

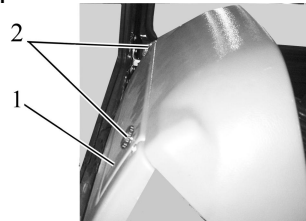

1 – cover of instrument board; 2 – screw.

Figure 2.20.1 – Arrangement of fuse blocks in the instrument board

Fuses, located in the instrument board, are shown in fig. 2.20.2.

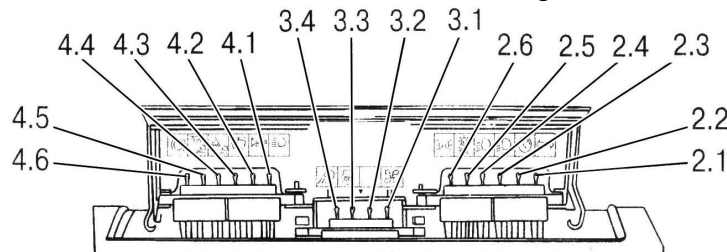
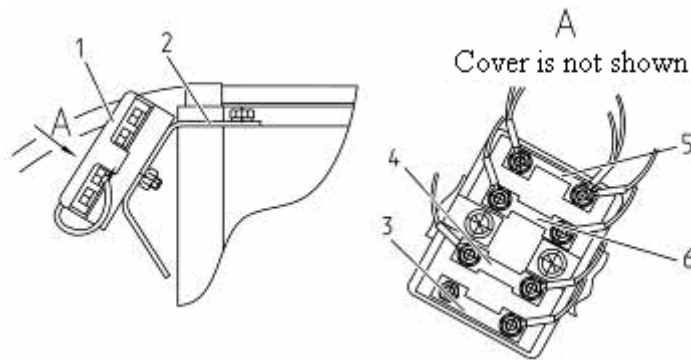

Figure 2.20.2 – Arrangement of fuses in the instrument board

Table 2.5 – Assignment of fuses in the instrument board

Number as per figure 2.20.2	Rated current	Name of protected circuit
Right fuse block		
2.1	15A	Power to turn flasher, power to heating plug controller
2.2	7,5 A	Gauges, pilot lamps unit, speed sensors, fuel sensor, relay coil of fuel filter heater, audible warning (buzzer)
2.3	7,5A	Lower beam of the right road light
2.4	7,5 A	Lower beam of the left road light
2.5	15A	Parking lights of the right side, terminal (5) of trailer socket, instrument illumination
2.6	7,5	Parking light of the left side, terminal (7) of trailer socket, number-plate light
Central fuse block		
3.1	25 A	Power to fan-heater or conditioner
3.2	25 A	Power to instruments, to side console before engine start-up, power to fuse 2.1, power to consumers of starter and instruments switch
3.3	25 A	Power to central light switch, to electronic control system of FDA and automatic DL (after engine start-up), fan-heater control
3.4	25 A	Front working lights, beacon, working lights on handgrips
Left fuse block		
4.1	25 A	Road lights upper beam, indicator lamp of upper beam activation
4.2	15 A	Audible beep
4.3	25 A	Front and rear window wipers, window washer
4.4	15 A	Warning light
4.5	15 A	Road-train lights, rear working lights, cab light
4.6	15 A	Braking lights, terminal (6) and terminal (8) of trailer socket

Apart from the fuses, located in the instrument board and shown in fig. 2.20.2 the on-board circuit of "BELARUS-1025.5" tractor has an additional block of fuses 1, located on the bracket 2 (Figure 2.20.3) of the HLL oil tank body and intended to protect power circuits of electrical equipment.



1 – fuse block, 2 – bracket; 3 – 80A fuse (power to on-board circuit before start-up, battery charging, positive side to starter relay leads, power to fuel filter heater); 4 – 80A fuse (power to heating plugs); 5 – 60A fuse (power to instrument board); 6 – 60A fuse (power to instrument board).

Figure 2.20.3 – Fuses, located on HLL oil tank body

Location of the fuse for a battery remote disconnect switch and a stereo-recorder is shown in figure 2.20.6. Besides a suspended 25A fuse is installed in the circuit of the battery remote disconnect switch.

2.20.3 Fuses for electronic systems to control DL and FDA

To access the cutout fuses for DL and FDA electronic control systems do the screws 2 out (Figure 2.20.4) on the cover of the side console 1 and open the cover.

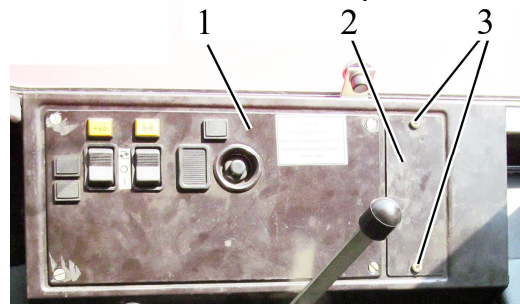

1 – side console; 2 – cover; 3 – screw.

Figure 2.20.4 – Access to fuses for electronic control system

The fuses for DL, FDA electronic control systems are shown in fig. 2.20.5/

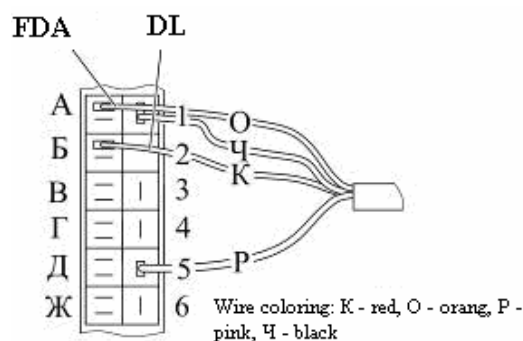

1 – 7.5A fuse for FDA drive control circuit;
2 – 7.5A fuse for rear axle DL control circuit.

Figure 2.20.5 – Fuses for DL and FDA electronic control systems

2.20.4 Fuse for engine electronic control system

The location of the fuses for the EECS 2 and 4 in the fuse block 3 is shown in fig. 2.20.6 (the fuse block 3 is located above the storage battery 1).

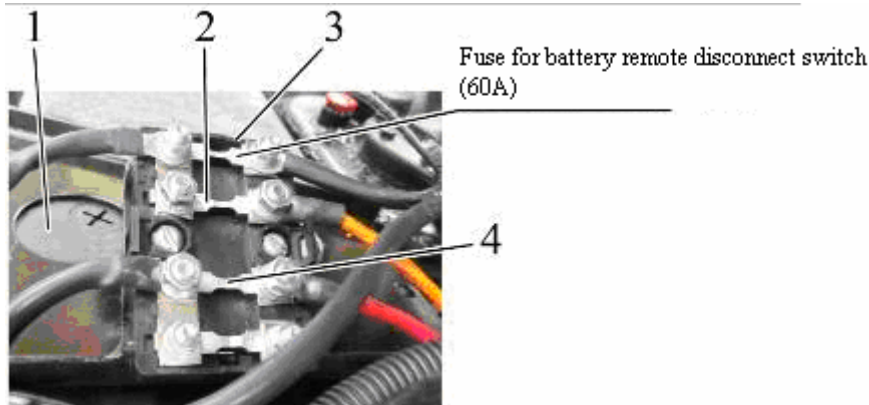

1 – storage battery; 2 – 60A fuse for EECS constant powering (at any position of the battery disconnect switch); 3 – fuse block; 4 – 80A fuse for EECS powering when the storage battery switch is in turned on position.

Figure 2.20.6 – Installation place of fuse for EECS powering

The other fuses for EECS are mounted in the protection and switching unit. switching and protection unit.

The protection and switching unit (PASU) of 1000 SCR series is intended to distribute power supply to tractor electronic control systems and to protect their electrical circuits against short circuit and current overload.

The PASU is installed in the rear part of the cab, at a special compartment behind the driver seat, as shown in figure 2.20.7.

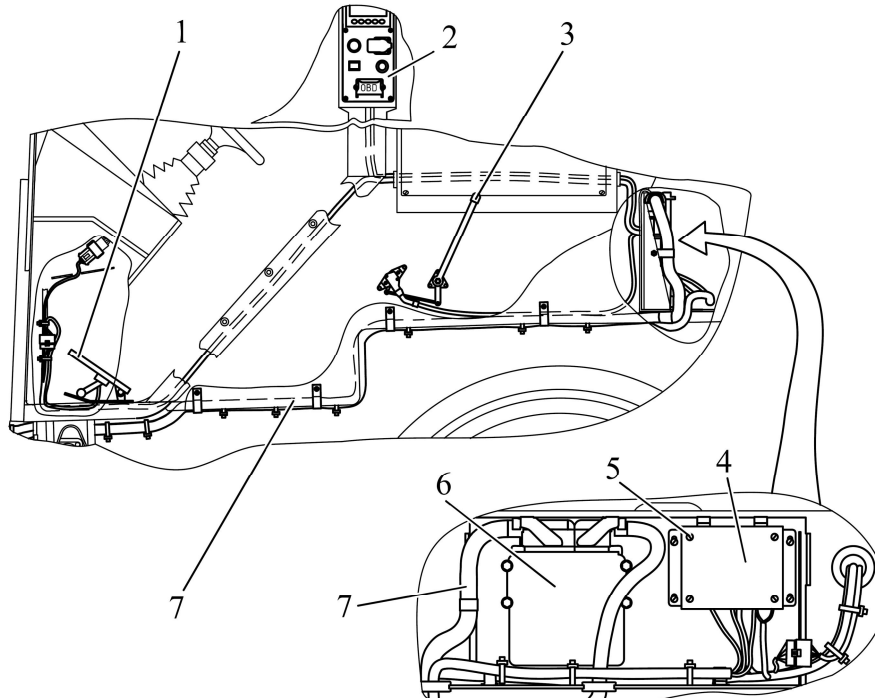

1 – electronic foot pedal to control fuel feed; 2 – console of engine control system; 3 – electronic handle to control fuel feed; 4 – protection and switching unit; 5 – screw; 6 – engine electronic control unit; 7 – connection bundles.

Figure 2.20.7 – Arrangement of EECS components in the cab

To access the PASU it is required to do four bolts out and open the cover of the special compartment. Then to access the relay and fuses of the PASU do four screws 5 out (Figure 2.20.7) and take the iron cover off.

The block includes ten fuses 1 (Figure 2.20.8) (F1...F10), seven electromagnetic relays 4 (K1...K7), commutating power supply for consumers. Each fuse has got warning LEDs of red color mounted on the front panel nearby which are intended to warn that the corresponding fuse blew out. Besides there are warning LEDs of yellow color 2 and 3. The LED 2 indicates continuous power supply to PASU, regardless of the position of the battery switch. The LED 3 indicates presence of continuous power, supplied to PASU only with the battery switch turned on.

The arrangement diagram of fuses, relays and other components of PASU is given in figure 2.20.8. .

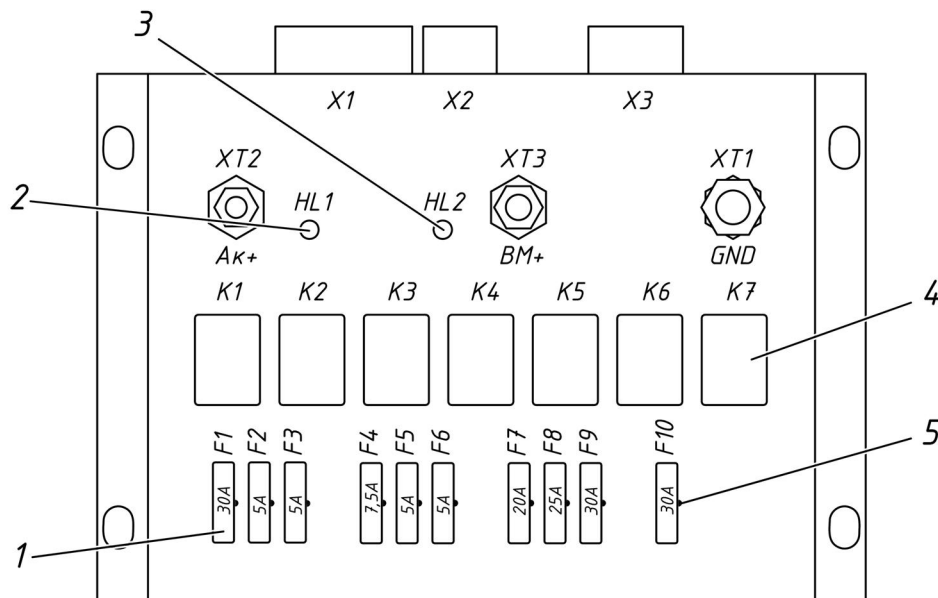

1 – fuse; 2, 3 – warning LED of yellow color; 4 – electromagnetic relay; 5 – warning LED of red color.

Figure 2.20.8 – Protection and switching unit

Information on assignment and rating of fuses and on assignment of relays is given in Tables 2.6 and 2.7 accordingly.

Electric connection of bundles of electronic control systems to connectors X1...X3 (Figure 2.20.8) and to leads XT1...XT3 of the PASU shall be carried out in accordance with table 2.8.

Table 2.6 – Assignment of PASU fuses

Fuse identification	Assignment of fuse (protected electric circuit)	Fuse rating
F1	Power to EECS (terminal 30)	30A
F2	Power to heavy-duty relay (not used)	5A
F3	Power to information display	5A
F4	Protection of circuit of power supply after the instruments are on (terminal 15)	7,5A
F5	Protection starter actuation control circuit (terminal 50) (not used)	5A
F6	Power to testing equipment	5A
F7	Power to cigar lighter	20A
F8	Power to electrical socket	25A
F9	Power to SCR heater	30A
F10	Protection of heater "ground" circuit	30A

Table 2.7 – Assignment of PASU relay

Relay identification	Assignment of relay
K1	Relay of power supply to engine electronic control unit EDC (not used)
K2	Relay of power supply after instruments are turned on
K3	Common power supply to SCR heaters
K7	Power supply to SCR heaters
K4	Activation of a heater for SCR charging hose
K5	Activation of a heater for SCR drain hose
K6	Activation of a heater for SCR intake hose
K7	Activation of a heater of SCR supply module

Table 2.8 – Connection of wire bundles to PASU

Connector (contact)	Component being connected
X1	Bundle of engine electronic control system
X2	Bundle of electric socket and heater, located on the engine control panel
X3	SCR bundle
XT1	Black wire or with “Ч” mark, with tag M8 – PASU ground
XT2	Yellow wire or with “Ж” mark, with tag M5 – constant DC supply to PASU (+12V) regardless of battery switch position
XT3	Red wire or with “K” mark, with tag M6 – power to PASU (+12V), supplied to PASU only with the battery switch turned on

2.21 Cab locks and handles

2.21.1 Cab door locks

Left and right doors of tractor cab are secured with locks 4 (figure 2.21.1). The lever 5 serves to open the left and right cab doors from inside the cab. Moving the lever 5 backward unlocks the door. The locks of the right and left doors can be blocked from inside the cab. To block the lock from inside the cab it is needed to shift the detent 3 into the lower extreme position.

With the lock 4 unblocked the left door is opened from outside by pushing the button 2 of the handle.

The lock of the cab left door can be opened and closed from outside. To close it from outside do the following:

- insert a key 1 into the hole of the cylinder mechanism, which is located in the button 2;

- without pushing the button 2 turn the key into position "closed".

To open the left door lock outside the cab, it is necessary to insert the key 1 into the hole of the cylinder mechanism, which is located in the button 2 and without pushing the button 2 turn the key into position "opened", then press the button 2.

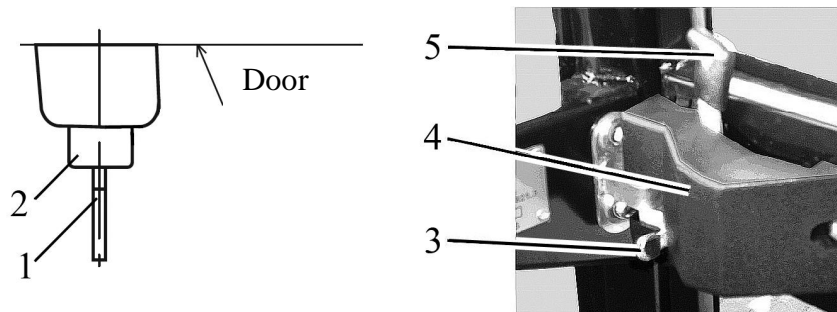

1 – key; 2 – button; 3 – detent, 4 – lock; 5 – lever.

Figure 2.21.1 – Cab door lock

2.21.2 Left-side window opening

To open the left-side window 1 (Figure 2.21.2) it is required to take a handle 2 up and push to secure the side window 1 in an opened position.

To close the left-side window 1 take the handle 2 up and pull to secure the side window 1 in a closed position.

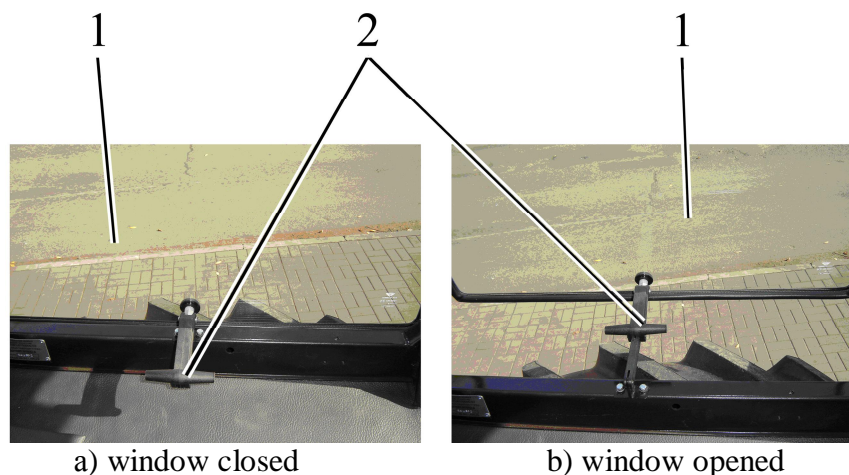

a) window closed

b) window opened

1 – left-side window; 2 – handle.

Figure 2.21.2 – Side window opening

2.21.3 Rear window opening

To open the rear window 2 (figure 2.21.3) turn a handle 1 upwards (counterclockwise) and push rear window away. Under the influence of airlifts 3 it will take tilt position.

To close the rear window pull the handgrip 4 on until the window is fixed in window aperture, turn handle 1 clockwise until handle detent planes into coincidence with bracket forming.

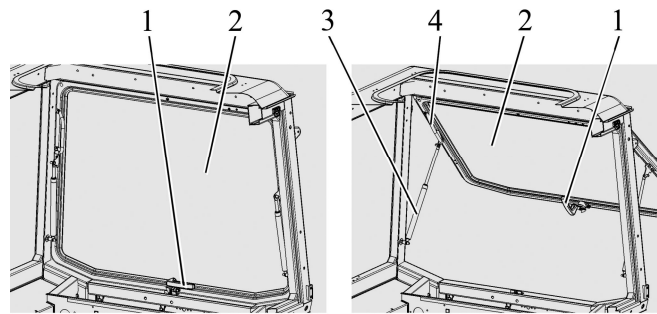

a) rear window closed
b) rear window opened
1 – handle; 2 – rear window; 3 – airlift; 4 – hand grip.

Figure 2.21.3 – Rear window opening

2.21.4 Cab roof opening

To open the roof 1 (figure 2.21.4) pull the hand grip 3 down, push detent 2 up and pressing it push hand grip 3 with the roof 1 up, until the roof is fixed in open position.

To close the roof 1 pull the hand grip 3 down until the roof 1 is fixed in a close position (the latch 5 shall be fixed in the bracket 4).

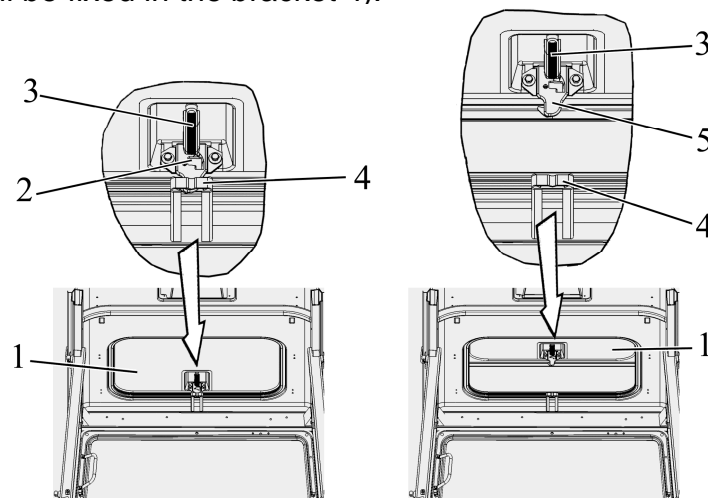

a) roof closed
b) roof opened
1 – roof; 2 – detent; 3 – hand grip; 4 – bracket; 5 – latch.

Figure 2.21.4 – Cab roof opening

2.21.5 Cab emergency exits

The cab has the following emergency exits:

- doors – left and right;
- rear window;
- roof.
- left-side window.

2.22 Seat and its adjustments

2.22.1 General information

The seat has a mechanical suspension, consisting of two spiral torsion springs and a gas charged shock absorber of bidirectional operation. A “scissors”-type guiding mechanism ensures a strictly vertical movement of the seat. A dynamic seat stroke is 100 mm.

ATTENTION: BEFORE STARTING TO OPERATE THE TRACTOR ADJUST THE SEAT TO REACH THE MOST COMFORTABLE POSITION. CARRY OUT ALL ADJUSTMENTS WHEN STAYING IN THE SEAT! THE SEAT IS CONSIDERED CORRECTLY ADJUSTED ACCORDING TO THE MASS IF IT MOVES HALF OF THE STROKE UNDER THE OPERATOR'S WEIGHT (THE SUSPENSION STROKE IS 100 MM)!

2.22.2 Adjustments of BELARUS seat

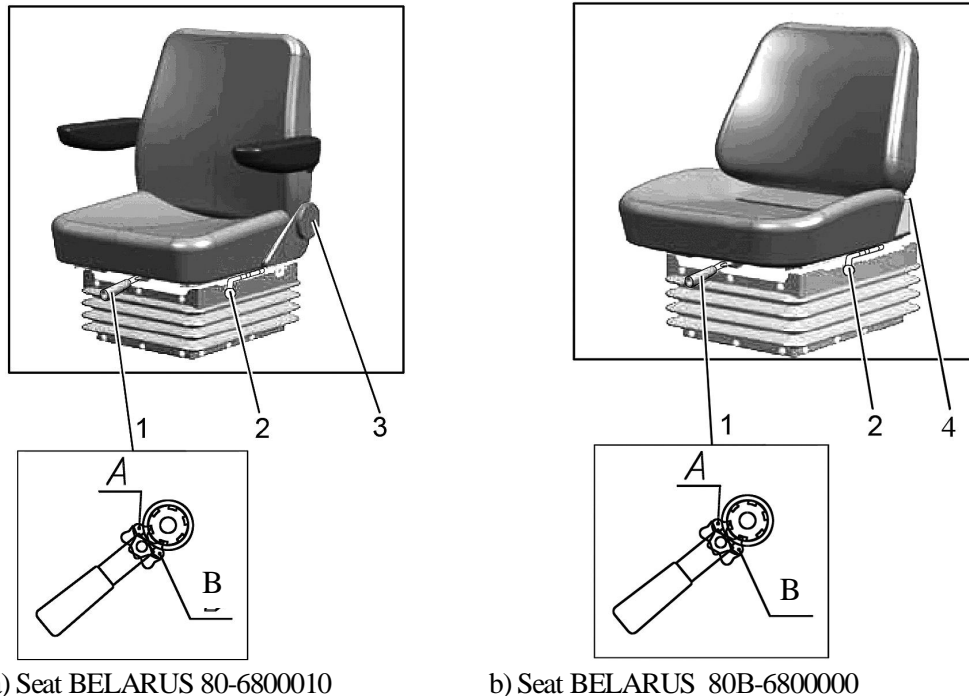

a) Seat BELARUS 80-6800010

b) Seat BELARUS 80B-6800000

1 – handle to adjust according to the weight; 2 – handle for longitudinal adjustment; 3 – hand wheel to adjust the backrest tilt. 4 – handle to adjust the backrest

Figure 2.22.1 BELARUS seat adjustments

The seat “BELARUS” has the following adjustments:

- adjustment according to the operator's weight. It is carried out by means of a handle 1 (figure 2.22.1) within the range from 50 to 120 kg. To adjust the seat for a bigger weight it is required to shift the pawl of the lever 1 into position “A” and tighten the springs with a reciprocal movement. To adjust the seat for a smaller weight it is required to shift the pawl into position “B” and release the springs with a reciprocal movement.

- longitudinal adjustment. It is carried out by means of a handle 2 within the range of ± 80 mm from the middle position. To move the seat forward-backward it is required to pull the handle 2 up, move the seat and then release the handle. The seat will automatically get locked in a required position.

- adjustment of the backrest angle:

- a) For the seat “BELARUS 80-6800010” the backrest tilt angle is adjusted by means of a hand wheel 3 within the range from minus 15° to plus 20° . To increase the backrest tilt angle it is necessary to turn the hand wheel clockwise, to decrease it – counterclockwise.

- b) For the seat “BELARUS 80B-6800000” the backrest tilt angle is adjusted by means of handle 4 within the range from plus 5° to plus 25° . To change backrest tilt angle it is required to pull the handle 4 up to the stop, move the backrest to the necessary direction to achieve the required angle and then release the handle. The seat will get locked in a required position.

- height adjustment is carried out within the range of ± 30 mm from the middle position. The seat has three height positions: “lower”, “middle” and “upper”. To move the seat from the “lower” position to the “middle” position or from the “middle” position to the “upper” one it is required to lift the seat up smoothly till the arresting stop goes off (a specific click is heard). To move the seat from the “upper” position into the “lower” one it is necessary to lift the seat up against the stop with an abrupt movement and let it down. It is impossible to move the seat from the “middle” position to the “lower” one.

2.22.3 Adjustments of Grammer seat

Your tractor can be equipped upon request with Grammer seat (Figure 2.22.2).

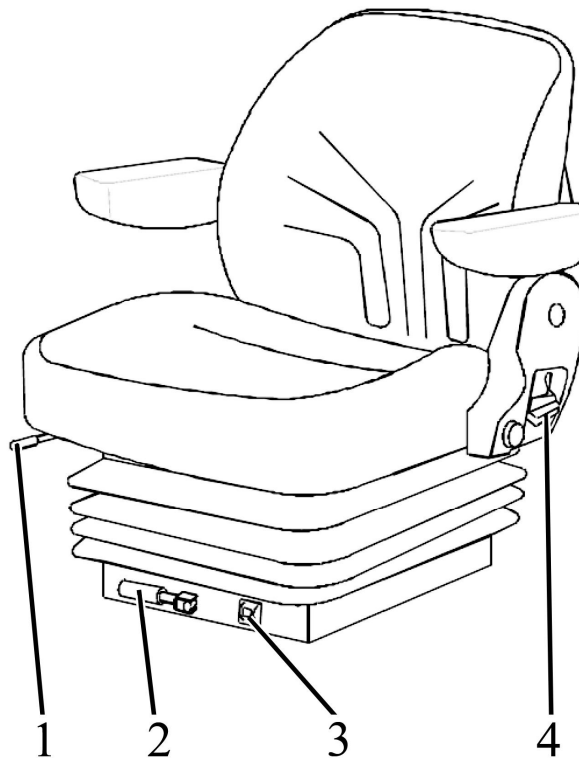

1 – handle for longitudinal adjustment; 2 – handle to adjust according to the weight; 3 – indicator of seat adjustment according to the weight; 4 – handle to adjust the backrest tilt.

Figure 2.22.2 – Grammer seat adjustments

The Grammer seat has the following adjustments:

- adjustment according to the operator's weight. It is carried out by means of a handle 2 (figure 2.22.2) within the range from 50 to 130 kg with weight indication in 10 kg. To adjust the seat for a bigger weight it is required to turn the handle clockwise, to adjust the seat for a smaller weight – turn it contraclockwise.
- longitudinal adjustment. It is carried out by means of a handle 1 within the range of ± 75 mm from the middle position. To move the seat forward-backward it is required to pull the handle 2 up, move the seat and then release the handle. The seat will automatically get fixed in a required position.
- adjustment of the backrest tilt angle. The backrest tilt angle is adjusted by means of a lever 4 within the range from minus 10° to plus 35° . To change the backrest tilt angle it is required to pull the handle 4 up to the stop, move the backrest to the necessary direction to achieve the required angle and then release the lever. The seat will get locked in a required position.
- height adjustment. It is carried out within the range of ± 30 mm from the middle position. The seat has three height positions: "lower", "middle" and "upper". To move the seat from the "lower" position to the "middle" position or from the "middle" position to the "upper" one it is required to lift the seat up smoothly till the arresting stop goes off (a specific click is heard). To move the seat from the "upper" position into the "lower" one it is necessary to lift the seat up against the stop with an abrupt movement and let it down. It is impossible to move the seat from the "middle" position to the "lower" one.

2.23 Controlling drive of transmission hydraulic system pump

The drive of the transmission hydraulic system pump is located on the left side of the gearbox body.

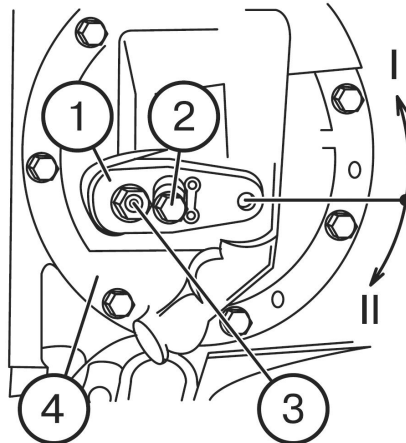

1 – lever; 2 – bolt; 3 – centre pin; 4 – gearbox pump drive assembly.

Figure 2.23.1 – Controlling drive of transmission hydraulic system pump

The lever 1 (Figure 2.23.1) of the transmission hydraulic pump drive can have two fixed positions:

- position I – “Pump drive on” (normal operating position) – the lever 1 is turned contraclockwise (when you look at gearbox from the tractor left) relative to the center pin 3 until the lower edge of the groove in the lever 1 stops and then locked with the bolt 2.
- position II – “Pump drive off” (inoperative) position.

Shift the lever 1 to position II if it is required to mount and to dismantle the gearbox pump drive assembly 4, and then lock the lever 1 in position I again.

Note – The figure 2.23.1 shows position “the transmission hydraulic system pump drive is on”.

ATTENTION: TURN THE TRANSMISSION HYDRAULIC SYSTEM PUMP DRIVE ON AND OFF ONLY WITH THE ENGINE NOT RUNNING OR WITH MIN. IDLE SPEED OF THE ENGINE!

2.24 Controlling pneumatic system compressor

Handle to turn the pneumatic system compressor 1 on (figure 2.24.1) has two positions:

- left (the arrow on the handle is directed forward as viewed along tractor movement) – “compressor off”,
- right (the arrow on the handle is directed backward to tractor cab) – “compressor on”.

ATTENTION: TURN THE PNEUMATIC SYSTEM COMPRESSOR ON AND OFF ONLY WITH THE ENGINE NOT RUNNING OR WITH MIN. IDLE SPEED OF THE ENGINE!

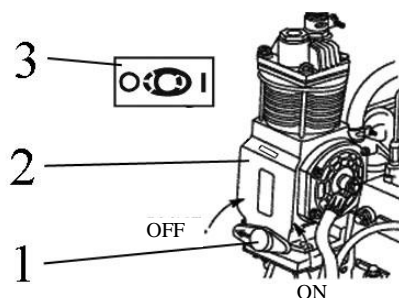

1 – handle to turn the pneumatic system compressor on; 2 – pneumatic system compressor; 3 – diagram of pneumatic system compressor control.

Figure 2.24.1 – Pneumatic system compressor control

Note – The figure 2.24.1 shows position “pneumatic system compressor off”.

2.25 Connector elements of the electrical equipment

2.25.1 Socket to connect coupled agricultural equipment

A standard seven-pin socket with an additional receiver to connect a portable lamp (figure 2.25.1) is intended to connect current consumers of a trailer or trailed agricultural implement. It is mounted on the rear cab support. A male plug of wire harness from a trailer or coupled agricultural implements is connected to the socket.

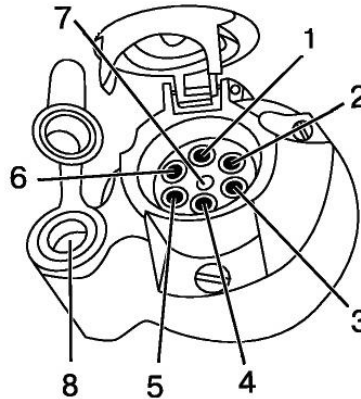

1 – left turn indicator; 2 – horn; 3 – ground; 4 – right turn indicator; 5 – right clearance lamp; 6 – brake light; 7 – left clearance lamp; 8 – receiver to connect a portable lamp or other electrical elements with useful current up to 8A.

Figure 2.25.1 – assignment of seven-pin socket terminals with an additional receiver to connect a portable lamp.

2.25.2 Connection of additional electrical equipment of coupled machines

To control the working process of coupled machines it is assumed to install control equipment (control consoles), which belongs to the coupled machine.

Coupled machines are equipped with various electrical and electronic units, the activity of which can influence readings of tractor instruments. Thus, the used electrical instruments shall have a certificate of electromagnetic compatibility as per international requirements.

Connect electrical equipment of coupled machines to the following elements of tractor electrical equipment:

1. Seven-pin socket (type 12N, GOST 9200, figure 2.25.1) – permissible input current is not higher than 10A, the electrical circuit is protected by a fuse in tractor electrical equipment:

- “+” to terminal No5 of the socket;
- “-“ to terminal No3 of the socket (it is possible to connect the coupled machine electrical consumer with the parking lights of this machine on).

2. Two-pin socket (ISO 4165:2001), located on the body of the seven-pin socket (figure 2.25.1).

- (terminal No8) – permissible input current is not higher than 12A, the electrical circuit is protected by a fuse in tractor electrical equipment;

3. Tractor alternator.

- “+” to terminal “B+” of the alternator (terminal diameter = 8mm).

- “-“ to engine housing.

4. Electric socket and cigar lighter, mounted in the engine control panel.

ATTENTION: WHEN CONNECTING THE ELECTRICAL EQUIPMENT OF IMPLEMENTS COUPLED WITH THE TRACTOR CONTACT YOUR DEALER AS WRONG CONNECTION OF ELECTRICAL EQUIPMENT OF IMPLEMENTS MAY RESULT IN TRACTOR ELECTRICAL EQUIPMENT BECOMING FAULTY!

2.26 Creeper control

Against order your tractor can be equipped with a creeper.

The creeper is intended to be mounted on tractors, coupled with implements, requiring low speeds of travel.

The creeper reduces each tractor speed at the gears of the first and second range for forward and reverse travel by 4.5 times.

If you need to use the gears of the first range for forward and reverse travel with their rated ratio it is enough to turn off the creeper.

The creeper is controlled by a double-lever mechanism with links 1 and 2 (Figure 2.26.1), brought into the cab to the left of the driver's seat.

The creeper shall be operated in the following way:

- to turn on the creeper it is required to depress the clutch pedal and to move the link 1 which is close to the driver's seat down with the idle speed of the engine;
 - then before starting to move engage the required gear with the gear levers and releasing the clutch pedal smoothly, shift the link 2 of the creeper, which is farthest from the driver's seat, up;
 - to change the gear depress the clutch pedal, engage the required gear with the gear levers and release the clutch pedal smoothly;
 - to turn off the creeper force the link 2 in, and pull the link 1 out until pushers of both links get secured by the securing mechanism, located in the creeper body.
- The design of the securing mechanism excludes the possibility of simultaneous shifting of both links as well as their engagement one by one.

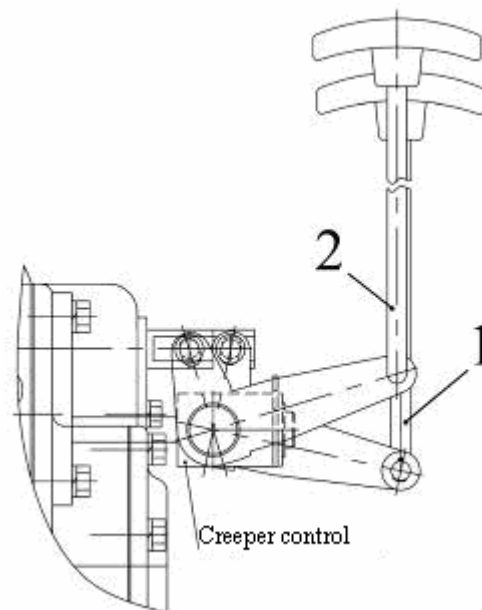

1, 2 – creeper control links.

Figure 2.26.1 – Creeper control elements

ATTENTION: IT IS TECHNICALLY POSSIBLE TO TURN ON THE CREEPER AT GEARS OF THE SECOND RANGE FOR FORWARD TRAVEL AND FOR REVERSE. BUT IN ORDER TO AVOID FAILURE OF THE TRANSMISSION AND OVERHEATING OF OIL IT IS FORBIDDEN TO OPERATE THE TRACTOR WITH THE CREEPER TURNED ON AT GEARS OF THE SECOND RANGE FOR FORWARD TRAVEL AND FOR REVERSE!

ATTENTION: TO OBTAIN ADDITIONAL INFORMATION ON PECULIARITIES OF OPERATION AND MAINTENANCE OF TRACTORS EQUIPPED WITH THE CREEPER, CONTACT YOUR DEALER!

3 INTENDED USE OF TRACTOR

3.1 Safety measures to be taken preparing tractor for operation

Strict observance of safety requirements ensures safe operation of the tractor and improves its reliability and durability.

Only persons not younger than 17, holders of a tractor driving license, who have been briefed on accident and fire prevention, may be admitted to operate the tractor of drawbar category 1.4.

Prior to operating the tractor, scrutinize the Operator's Manual and the Engine operation manual. Insufficient knowledge of tractor controls and servicing is a potential of likely accidents.

When performing depreservation of the tractor and optional equipment, follow the fire prevention instructions and sanitary requirements when dealing with chemicals, rag wastes and oiled paper.

Before starting to operate the tractor replace special nuts of rear wheel hubs (one at each hub), used for tractor fastening on the vehicle platform, with the nuts of basic hub configuration, attached in a set of spare parts, tools and accessories. Tighten the nuts with a torque of 300...350 Nm. Replace special nuts of front wheels (one at each wheel), used for tractor fastening on the vehicle platform, with the nuts of basic wheel configuration, attached in a set of spare parts, tools and accessories. Tighten the nuts with a torque of 200...250 Nm.

The tractor should be run in, in accordance with the requirements under subsection 3.4 "Tractor final assembly and run in".

The tractor should be completely outfitted and in good working order.

DO NOT allow dismantling of design-stipulated protective enclosures or safeguards from the tractor, as well as other parts and assembly units which affect its safe operation (protective guard of the fan, rear PTO enclosure, etc.)

The technical condition of the braking system, steering controls, lighting and indication devices and the drive system should conform to safety requirements of relevant standards and the present Manual.

The trailed agricultural machines and harvest trailers shall be fitted with rigid coupling which excludes swaying and colliding thereof with the tractor during the transportation.

The tractor controls shall be provided with reliable locking in their operative positions.

Keep all the warning tabs of the tractor clean and readable. If damaged or lost, replace them with new ones.

Tractor use without availability of the accumulator battery in the electrical equipment system is not allowed.

The first aid kit shall be completed as per regulations, adopted in the territory of the state, where the tractor is used.

3.2 Tractor use

3.2.1 Boarding the tractor

The tractor is boarded through the cab left door. To make tractor boarding easier there is a foot step.

3.2.2 Preparing for start and starting the engine

To start the engine of tractor "BELARUS-1025.5" perform the following actions:

- engage the tractor parking brake;
- if required, fill in fuel and bleed the fuel delivery system to remove air;
- set the fuel feed control handle into the position that corresponds to the minimum fuel supply;
 - make sure that the electronic pedal of fuel feed control is in its initial position and it is not affected by physical influence. Do not press the fuel feed control pedal when starting the engine;
 - FDA drive control switch shall be set in "off" position
 - set the rear PTO drive handle into position "PTO drive off", and the rear PTO actuating link into position "PTO is off".
 - the handles of the hydraulic system valve group control (or joystick with lever) shall stay in "neutral" position, the switches of the rear axle DL, shall stay in "off" position;
 - set the levers shifting the GB ranges and speeds into a neutral position;
 - turn on the accumulator battery switch;
 - turn the key of the starter and instruments switch from "0" position into position "I".

Herewith:

1) On the integrated indicator both RPTO scale range annunciators as well as all RPTO scale segments will turn on for not more than one second, and the needles of engine speed and rpm indicators deviate from their initial positions (or the needles "shake" on indicator zero marks for not more than one second) – thus confirming workability of LED annunciators and needle indicators.

2) The engine control system panel carries out a self-check. If there are no errors in the system operation, the fault testing annunciator on the engine control system panel shall light up and go out, thus confirming workability of the annunciator lamp and its correct connection to the tractor on-board system. If the errors are detected, the testing annunciator provides a light code of the fault. The detected faults shall be eliminated before the engine is started.

3) The information screen displays a company logo for several seconds – thus confirming workability of the screen. Then in case there are no failures with the EECS operation, the information screen functions in operation mode – it displays actually measured parameters of the engine. If failures are detected, the information screen produces an acoustic signal, and a brief description of the detected failures emerges on the screen. The failures detected shall be eliminated before the engine is started.

4) On the pilot lamp unit a pilot lamp of emergency oil pressure in HSC will light up. On the dashboard a signal lamp of oil emergency pressure in engine lubrication system (and a buzzer sounds), a signal lamp of air emergency pressure in the pneumatic system (if it is below the accepted value), a signal lamp of fuel reserve capacity in the tank (when reserve volume of fuel remains in the tank). On the integrated indicator a pilot signal annunciator of engaged parking brake will turn on in a flashing mode with 1 Hz frequency.

5) On the pilot lamp unit a pilot lamp that indicates heating plug operation will light up.

- after the heating plug pilot lamp goes out, start the engine, to do this depress the clutch pedal and turn the key of starter and instruments switch from "I" position ("instruments on") into position "II" (engine start);
- hold the key of the starter switch turned until the engine is started, but not longer than 15...20 seconds; if the engine has not started, a repeated start-up shall be carried out not earlier than after one minute;
- after the engine is started, release the clutch pedal, check function of all signal lamps and gauge indications (coolant temperature, oil pressure in the engine, on-board

circuit voltage, etc.). Let the engine run at low rpm until pressure stabilizes within gauge operation range. Actually measured parameters and operation states of tractor systems and units are displayed on the integrated indicator, on the dashboard, on the pilot lamp unit, on the control panel of the rear axle DL, of FDA drive, on the engine control system panel and on the information screen. On RLL control panel the annunciator of testing electronic systems controlling RLL, lights up, thus indicating the workability and blocking of the RLL control system;

IT IS FORBIDDEN TO OPERATE THE TRACTOR IN CLOSED ROOMS WITHOUT A REQUIRED VENTILATION (AIR EXCHANGE). EXHAUST GASES MAY LEAD TO A LETHAL OUTCOME!

IT IS FORBIDDEN TO RUN THE ENGINE WITH THE SYSTEMS OF COOLING AND ENGINE LUBRICATION UNFILLED!

ATTENTION: THE TRACTOR CAB IS EQUIPPED WITH A SINGLE-OCCUPANCY SEAT AND THE OPERATOR IS THE ONLY PERSON TO STAY IN!

ATTENTION: START THE ENGINE AND INSPECT GAUGES ONLY WHEN STAYING IN THE OPERATOR'S SEAT!

ATTENTION: KEEP IN MIND THAT THE ENGINE START IS POSSIBLE ONLY WHEN THE RANGE SHIFTING LEVER IS SET INTO A NEUTRAL POSITION!

ATTENTION: THERE MUST BE NO PEOPLE UNDER BEFORE AND BEHIND THE TRACTOR, AND BETWEEN THE TRACTOR AND AN IMPLEMENT COUPLED TO IT!

IT IS FORBIDDEN TO START THE ENGINE TAKING THE TRACTOR IN TOW, AS IT MAY RESULT IN ENGINE BREAKDOWN. START THE ENGINE ONLY WHEN YOU STAY IN THE OPERATOR'S SEAT!

3.2.3 Tractor motion start, GB shifting

ATTENTION: YOUR TRACTOR IS EQUIPPED WITH TURBOCHARGED ENGINE. HIGH SPEED OF THE TURBOCHARGER REQUIRES GOOD LUBRICATION AT ENGINE START. AFTER STARTED WARM UP THE ENGINE TO ACHIEVE STABLE RUNNING UNDER THE CRANKSHAFT SPEED OF 1000-1300 RPM (FOR 2-3 MIN), AND THEN LET IT RUN AT HIGHER SPEED, GRADUALLY INCREASING THE SPEED UP TO 1600 RPM (NOT MORE) UNTIL THE COOLANT TEMPERATURE REACHES 40°C.

TRACTOR OPERATION IS FORBIDDEN, IF THE ENGINE EMERGENCY OIL PRESSURE LAMP IS ON WITH THE ENGINE RUNNING, STOP THE ENGINE IMMEDIATELY!

Before starting to move define a necessary speed of tractor movement. The speed diagram of the tractor "BELARUS-1025.5" with tires of basic configuration is given in the instruction table attached to the right glass of the cab and also in subsection 2.14.2. "Tractor velocity diagram".

To put the tractor in motion the following shall be done:

- reduce engine speed;
- depress the clutch pedal;
- set a required gearbox range using the range shifting lever as per the range shifting diagram;
- set a desired speed, for this shift the speed and pass shifting lever from neutral ("N") into any of positions, as per the speed shifting diagram;
- disengage the parking break, slowly release the clutch pedal, increasing at the same time fuel feed. The tractor will start moving.

IT IS FORBIDDEN TO START MOVEMENT WITH BIG TRACTION LOAD!

IT IS FORBIDDEN TO MOVE THE TRACTOR WITH THE DOOR OPEN!

ATTENTION: SHIFT RANGES AND SPEEDS ONLY WITH THE TRACTOR STOPPED AND THE CLUTCH PEDAL FULLY DEPRESSED! PERFORMING TRANSPORT OPERATIONS IT IS PERMITTED TO SHIFT SPEEDS WITHIN A RANGE. THE SHIFTING SHALL BE CARRIED OUT AS THE TRACTOR COASTS AND THE CLUTCH PEDAL FULLY DEPRESSED!

ATTENTION: DON'T HOLD THE FOOT ON THE CLUTCH PEDAL DURING TRACTOR OPERATION, BECAUSE IT CAN LEAD TO CLUTCH SLIPPING, ITS OVERHEATING AND FAILURE!

ATTENTION: TO ENGAGE THE SPEED SMOOTHLY, WITHOUT SHARP PUSHES, MOVE THE SPEED LEVER ACCORDING TO THE DIAGRAM AND HOLD IT PRESSED UNTIL THE SPEED IS FULLY ENGAGED!

ATTENTION: STARTING TO MOVE, MAKE SURE THE PARKING BRAKE IS DISENGAGED!

ATTENTION: WITH THE DIFFERENTIAL LOCK ENGAGED THE TRACTOR MOVEMENT SHALL NOT EXCEED 13 KM/H!

ATTENTION: OPERATING ON ROADS WITH HARD SURFACE IT IS NECESSARY TO SWITCH THE FDA DRIVE OFF TO AVOID INCREASE WEAR OF FRONT WHEELS!

ATTENTION: IT IS ALLOWED TO USE THE ENGINE AT ITS FULL POWER ONLY AS THE COOLANT TEMPERATURE REACHES 70°C.

ATTENTION: TRACTOR OPERATION WITH EMPTY ADBLUE (UREA) TANK IS NOT ALLOWED! WHEN INFORMATION ABOUT CRITICAL LEVEL OF ADBLUE AGENT (UREA) IN THE TANK APPEARS ON MONITOR, IT IS NECESSARY TO FILL THE TANK WITH ADBLUE AGENT.

3.2.4 Tractor stop

To stop the tractor do the following:

- decrease engine speed;
- fully press the clutch pedal;
- set the range switching lever and the speed lever into neutral position;
- release the clutch pedal;
- stop the tractor by means of service brakes;
- engage the parking brake.

ATTENTION: FOR TRACTOR EMERGENCY STOP SHARPLY PRESS THE CLUTCH AND BREAK PEDALS TOGETHER!

3.2.5 Engine stop

ATTENTION: BEFORE STOPPING THE ENGINE, MOVE DOWN THE LIFT LINKAGES UNTIL THEY REACH GROUND, IF THEY ARE UPLIFTED; LET THE ENGINE RUN AT (1000±100) RPM FOR 3 TO 5 MINUTES. THIS WILL ALLOW TO REDUCE ENGINE COOLANT TEMPERATURE!

To stop the engine do the following:

- set the rear PTO control link into position “off” and the rear PTO lever changing the drive from continuous to ground-speed one (the ground-speed drive is on) set into “Neutral” position;
- disengage the rear axle differential lock, the FDA drive;
- shift the hydraulic lift linkage distribution valve group control lever into neutral position;
- turn the conditioner or heater fan off;
- turn the key of the starter and instruments switch from the position “I” into the position “0”;
- in case the rear PTO continuous drive is off, set the rear PTO lever changing the drive from continuous to ground-speed one into “Neutral” position;
- deactivate the accumulator battery when the engine is stopped for a long time.

ATTENTION: FOR ENGINE EMERGENCY STOP TURN THE KEY OF THE STARTER AND INSTRUMENTS SWITCH FROM THE POSITION “I” INTO THE POSITION “0”!

3.2.6 Leaving the tractor

Leaving the tractor is carried out through the cab left door, except for emergency situations. Rules on leaving the tractor at emergency situations are given in clause 3.5.3 of subsection 3.5 “Emergency actions”.

Leaving the tractor, make sure that all actions, listed in subsection 3.2.5 “Engine stop” have been performed, lift linkages of the tractor and of coupled implements have been lowered.

3.2.7 PTO use

The rules on engagement and disengagement of rear power take off shaft are described in subsection 2.16 “Rear power takeoff control”.

The rear power take off shaft operation is controlled by means of the integrated indicator as described in subsection 2.8.2 “Assignment and operation principle of integrated indicator gauges”.

The rules of RPTO coupling with different types of agricultural machines and implements are described in section 4 “Coupling of implements”.

ATTENTION: OPERATING WITH PTO OBSERVE ALL SAFETY MEASURES OF PTO OPERATION, WHICH ARE LISTED IN THE THIS OPERATION MANUAL!

ATTENTION: TO EXCLUDE IMPACT LOADS ENGAGE THE REAR PTO AT ENGINE SPEED CLOSE TO MINIMUM (BETWEEN 1000 AND 1100 RPM), THEN ENGINE SPEED SHOULD BE INCREASED.

The rear PTO of the tractor has a PTO end 1 (6 splines, 540 rpm) installed. Against order a PTO end 1c (8 splines, 540 rpm) and a PTO end 2 (21 splines, 1000 rpm) can be attached to the spare parts, tools and accessories kit of the tractor.

In their design and arrangement the rear PTO ends of "BELARUS-1025.5" tractor correspond to regulations and standards, applicable to PTO shafts of agricultural tractors.

ATTENTION: POWER TAKE OFF THROUGH REAR PTO AT 540 RPM MODE SHOULD NOT EXCEED 60 kW!

ATTENTION: POWER TAKE OFF THROUGH REAR PTO AT 1000 RPM MODE SHOULD NOT EXCEED 83 kW!

Table 3.1 – Operating modes of rear power take-off shaft

PTO drive	Shaft end extension	Rotation speed, min ⁻¹	
		PTO	of engine cardan shaft
Independent	PTO 1C	540	2037
	PTO 1	540	2037
	PTO 2	1000	2157
Synchronous with mounted rear tires 18.4R34	PTO 1C PTO 1 PTO 2	- 3,5 rotation/meter of track	

PTO shaft end rotation speed when the rated frequency of the engine crankshaft is 2200 min⁻¹, (when independent drive is on) is as follows:

- PTO 1C - 583 min⁻¹
- PTO 1 - 583 min⁻¹
- PTO 2 - 1020 min⁻¹

At operation with rear power take-off shaft in ground-speed mode the following shall be taken into account:

- PTO shaft end extension can rotate only when the tractor moves;
- operating tractor speed in structure of machine-tractor unit shall not exceed 8 km/h;
- the direction of rotation of PTO shaft end extension (on looking at PTO shaft end extension) is different at forward and back motion: at forward motion is clockwise, at back motion is counterclockwise.

For operation with PTO, remove the protective cap 2 (figure 3.2.1), that protects shaft end extension 6. For this it is necessary to squeeze the protective cap at its bottom and pull down. After finishing to operate with PTO it is obligatory that you put the protective cap back, to do this it is required to put the cap on the shaft end extension and to press it length way till the cap is securely fixed in the aperture of the plate 1.

If the cap is fixed by bolts, for operation with PTO, take off a protective cap that protects a shaft end extension, for this unscrew two fixing bolts. After finishing to operate with PTO it is obligatory that you put the protective cap back, by screwing of two bolts.



1 – plate; 2 – cap; 3 – bolt; 4 – bolt 5 – plate; 6 – shaft end extension

Figure 3.2.1 –Protective cap removal and exchange of PTO shaft end extension.

To exchange the shaft end extension proceed as follows:

- unscrew four bolts 3 and remove plate 1 with cap 2;
- unscrew sex bolts 4 remove plate 5 and shaft end extension 6;
- mount the other shaft end extension into spline opening, mount plate and other removed parts in reverse order.

3.2.8 Selection of optimal inner pressure in tires depending on operational conditions and load on tractor axles

3.2.8.1 Selection of optimal inner pressure in tires depending on operational conditions and load on tractor axles.

Selection of optimal air pressure in tires of wheeled tractors and rate of its influence on gripping abilities depend on soil type and load, applied to tractor axles. Air pressure in tires influences the wheel point being in contact with soil, and affects its gripping abilities as well as tractor operational performance depending on soil conditions. Rates of loads on tires to select operation mode at various inner pressures and speeds are set forth by a tire manufacturer and are provided in table 3.2.

The pressure value depends on travel speed and weight loads on tractor axles, created by weight of coupled implements with due account for tractor own weight and ballast weight and also operation conditions.

Inner pressure in tires for each specific case of tractor coupling with implements is different. Therefore if tractor operational conditions are changed it is required to check and if necessary adjust pressure value in tires. Failure to comply with pressure rates decreases tire life significantly.

Tractor operation with tire pressure set below the required rate results in the following wheel failures:

- tire turning on rims;
- wearing of tire bead against rim edge;
- occurrence of cracks on tire sides;
- ply separation or rupture of a tire;
- tear-out of tire valve (for tubed tires);

Operation with tire pressure higher than the rated pressure results in the following wheel failures:

- noticeable increased wear of tires;
- stretching of carcass layers and decrease of tire flexibility;
- increased skidding of wheels;
- increased sensitivity to impacts and cuts.

Extra duty operation resulting in excess of max. load capacity (for given pressure and speed) of tires and tractor axles is a reason for failures and damages not only to the undercarriage (tire carcass rupture, etc.) but also to other units and parts of the tractor, which can lead to accidents and decrease of the tractor life span in general.

ATTENTION: ALWAYS SET TIRE PRESSURE WITH DUE ACCOUNT FOR LOADS AND SPEEDS EFFECTIVE FOR THE KIND OF OPERATION BEING CARRIED OUT!

Correct choosing tire pressure as well as identifying if it is necessary to mount ballast weights, their mass and type is possible only after defining a load value on tractor axles.

The exact load value for a specific case of tractor use, which is applied to front and rear wheels of the tractor, can be determined only by way of practical weighing the tractor with the implement coupled.

The method of identifying load on front and rear wheels of the tractor by way of weighing is presented in section 4 "Coupling of implements".

To check tire pressure use properly-functioning devices with scale interval not more than 10 kPa. This will ensure adequacy of measurements. The permissible limit deviations for tire pressure are ± 10 kPa according to pressure gage readings.

Rates of loads on single tires of tractors “BELARUS-1025.5” to select operation mode at various inner pressures and speeds are provided in table 3.2.

Table 3.2

Tire	Load index**	Speed symbol**	Speed, km/h	Loading of tire, kg, at inner pressure, kPa					
				80	100	120	140	160	180
360/70R24	122	A8	10	1500	1635	1775	1910	2045	2250 (190 kPa)
			20	1340	1450	1580	1720	1845	
			30	1165	1265	1375	1500	1605	
			40	1090	1180	1285	1400	1500	
18.4R34	144	A8	10*	3030	3330	3615	3915	4200	
			20	2480	2730	2960	3210	3440	
			30	2160	2375	2575	2790	2995	
			40	2020	2220	2410	2610	2800	

* - inner pressure shall be increased by 25 %

** Load index and speed symbol (see on tire sidewall).

Rates of loads are provided for tires with indicated load index and speed symbol.

Pressure shall be set in “cold” tires.

Performing operations, requiring large pulling force on the hook, set the pressure as for the speed of 30 km/h. When performing transport operations on roads with solid surface increase the pressure by 30 kPa.

Tractor operation with twinned tires is permitted only at the speed of 20 km/h.

Total loading capacity of twinned tires shall not exceed the loading capacity of a single tire by more than 1,7 times;

When twinning, make sure the pressure of outer tires is 1,2 – 1,25 times lower, than the pressure of inner tires.

3.2.8.2 Tire inflation

Inflate tires through an air bleed valve of a pressure regulator 1 (figure 3.2.2), for this do the following:

- let air out of a balloon 3 of the pneumatic system through a condensate removing valve;
- unscrew a winged nut 2 of the air bleed valve cap;
- connect a pipe to inflate tires to the air bleed valve cap and to a tire valve;
- start the engine and inflate the tire to reach a required pressure, controlling it with a pressure gage;
- detach the pipe from the tire valve and from the air bleed valve cap;
- screw the winged nut back on the air bleed valve cap.

ATTENTION: AS PRESSURE IN THE BALLON GOES UP TO 0.77 MPA, THE COMPRESSOR IS SWITCHED TO IDLE RUNNING BY THE PRESSURE REGULATOR AND TIRE INFLATION STOPS AUTOMATICALLY. FOR THIS REASON CHECK THE PRESSURE OVER THE INDICATOR ON THE DASHBOARD FROM TIME TO TIME AND, IF NECESSARY, REDUCE IT THROUGH THE CONDENSATE REMOVING VALVE!

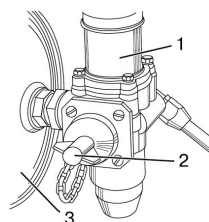

1 – pressure regulator; 2 – winged nut; 3 – balloon of the pneumatic system.

Figure 3.2.2 – Tire inflation

3.2.9 Rear wheel track formation

The rear wheel track with the wheels of basic configuration 18.4R34 is changed by moving the hub together with the wheel over the axle shaft and by replacing the wheels from one sideboard to the other one as shown in figure 3.2.3.

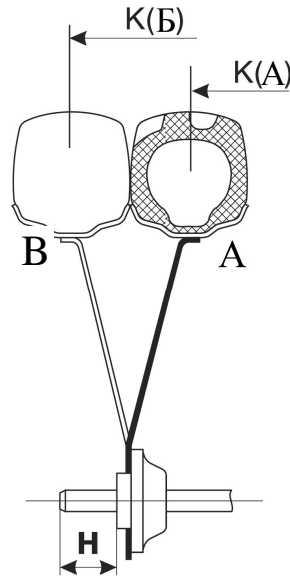

Figure 3.2.3 – Variants of rear wheel track settings by replacing the wheels from one sideboard to the other

Table 3.3 – Variant of rear wheel track setting (terminal hubs)

Tire size	Variant (Figure 3.2.3)	“K” track dimensions, mm	The installation dimension from the hub end face to the axle shaft end “H”, mm
18.4R34	A	K(A) 1500...1600	50...0
	B	K(B) 1800...2100	164...14

ATTENTION: EX-WORKS DELIVERED REAR WHEELS ARE SET TO A TRACK UNDER THE VARIANT A (FIGURE 3.2.3)!

To change the rear wheel track perform the following operations:

- put the tractor on a level ground, put the stops under the front and rear wheels, clean the axle shafts from dirt;
- jack up the corresponding axle tube;
- undo the nuts 1 (Figure 3.2.4) attaching the wheels and remove the wheels;
- release four bolts 2 of the rear wheel hubs by 3 to 5 turns;
- move the hub to one or other side to obtain the required width;
- tighten the four bolts 2 attaching the hub with a torque of 300 to 400 Nm;
- mount the wheel and tighten the nuts 1 with a torque of 300 to 350 Nm;
- repeat the operations on the opposite wheel.

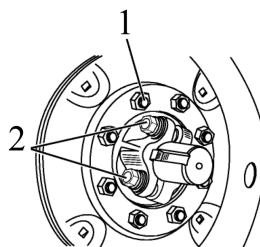

1 – nuts attaching the wheel to the hub; 2 – bolts attaching the hub to the axle shaft.

Figure 3.2.4 – Rear wheel track setting

Check tightening of the wheel attaching nuts and the hub attaching nuts after the first hour of operation, after the first eight-ten hours of operation and every subsequent 125 hours of operation.

Use table 3.4 and figure 3.2.5 to define the track width by changing the distance "A" from the axle shaft end to the hub face.

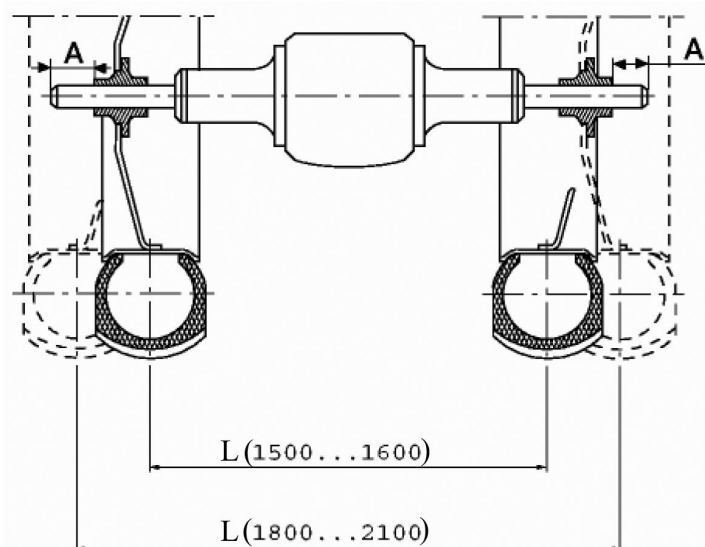

Figure 3.2.5 – Rear wheel track

Table 3.4 – Rear wheel track installation variants (terminal hubs)

Track width L, mm	Distance "A", mm
1440	80
1500	50
1600	0
1800	164
1900	114
2000	64
2100	14

Against order your tractor may be equipped with taper hubs of rear wheels. To get information on the rules of rear wheel track setting contact your dealer.

Table 3.4a – Rear wheel track installation variants (taper hubs)

Standard size of tires	Variant (Figure 3.2.3)	Dimension of track "K", mm	Mounting dimension from the hub end face to the axle shaft end "H", mm
18.4R34	A	K(A) 1500...1600	69...19
	B	K(B) 1800...2100	183...33

ATTENTION: EX-WORKS DELIVERED REAR WHEELS ARE SET TO A TRACK UNDER THE VARIANT A (FIGURE 3.2.3)!

3.2.10 Rear wheel twinning

With an aim to improve gripping properties of the tractor when coupled with heavy agricultural implements on soils with low bearing capacity, rear wheel twinning with use of spacers is provided.

To receive information on the rules of rear wheel twinning and operating restrictions for the tractors with rear wheels twinned, please, contact your dealer!

3.2.11 Front wheel track formation

The front wheel track is adjusted stepwise both by displacing the wheels from one sideboard to the other, and by changing a position of the wheel disk relative to the rim.

The front wheel track may have the following dimensions: 1415, 1515, 1585, 1685, 1735, 1835, 1900, 2000 (for short beam), и 1535, 1635, 1705, 1805, 1855, 1955, 2020, 2120 (for long beam).

Installation diagrams and track dimensions for tires 360/70R24 (basic configuration) are given in table 3.5.

Table 3.5 – Front wheel track adjustment

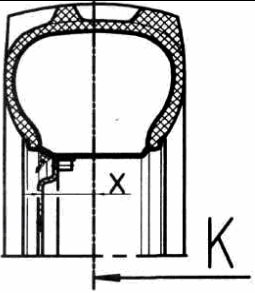
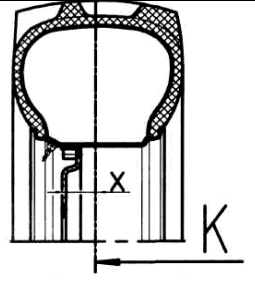
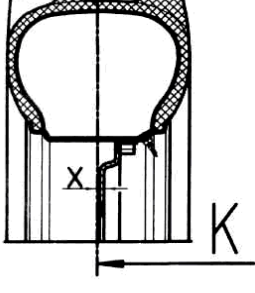
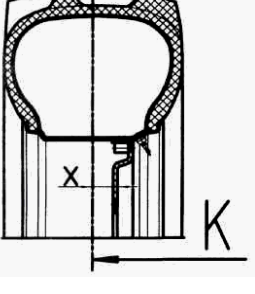
Variants of mounting the disk and the rim	Disk offset X, mm	Tractor track K, mm (tire 360/70R24)		Description of mounting method	
		Short beam	Long beam		
Standard disk mounting with rim displacement		+140	1415	1535	Main position. The inner surface of the disk mates with the gear group flange, and the disk is located from the outer side of the wheel support
		+90	1515	1635	Ex-works condition. The rim is displaced relating to the disk. The inner surface of the support mates with the disk.
		-18	1735	1855	The rim is turned by 180°. The disk mates with the support inner surface.
		-68	1835	1955	The rim is turned by 180°. The disk mates with the support outer surface.

End of table 3.5

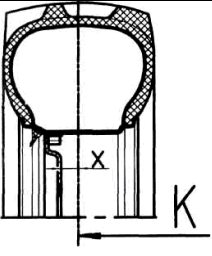
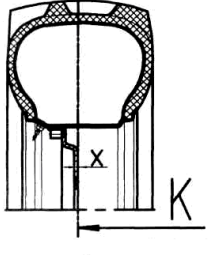
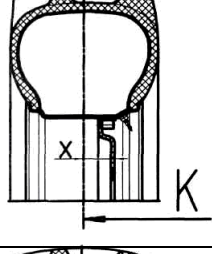
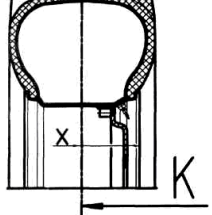
Variants of mounting the disk and the rim	Disk offset X, mm	Tractor track K, mm (tire 360/70R24)		Description of mounting method	
		Short beam	Long beam		
Displacement of the disk and the rim		+56	1585	1705	The disk mates with the support outer surface.
		+6	1685	1805	The disk mates with the support inner surface.
		-102	1900	2020	The rim is turned by 180°. The disk mates with the support inner surface.
		-152	2000	2120	The rim is turned by 180°. The disk mates with the support outer surface.

To set a required track proceed as follows:

- brake the tractor using the parking brake. Put stop members at the front and at the back of the rear wheels;
- jack up the tractor front part (or front wheels one by one), ensuring clearance between the wheels and the ground;
- to obtain the track by displacing the wheel from one sideboard to the other one without changing disk position with respect to the rim, unscrew the nuts fastening the wheel disk to the gear group flange, take the wheels off and change from one sideboard to the other one,
- to obtain the track by changing disk position relative to the rim with the wheels taken off the tractor, unscrew the nuts fastening the wheel rim to the disk and depending on the track required, set mutual arrangement of the rim and the disk as shown in the diagram in table 3.5.

Mounting the wheels make sure the wheel rotation direction coincides with the direction of an arrow on tire side.

The tightening torque for the nuts attaching plates to the gear group flanges shall make 200 to 250 Nm;

The tightening torque for the nuts attaching plates to the rim brackets shall make 180 to 240 Nm.

ATTENTION: AFTER YOU HAVE MOUNTED THE WHEELS CHECK NUTS FOR TIGHTENING AFTER THE FIRST OPERATION HOUR, AFTER 10 OPERATION HOURS AND EVERY 125 HOURS OF OPERATION!

ATTENTION: AFTER YOU HAVE CHANGED THE FRONT WHEEL TRACK CARRY OUT CHECK AND ADJUSTMENT OF FRONT WHEEL TOE-IN. BEFORE CHECKING THE TOE-IN MAKE SURE TO CHECK AND, IF NECESSARY, ADJUST PLAY IN STEERING JOINTS!

3.3 Safety measures to be taken when operating the tractor

3.3.1 General safety measures to be taken when operating the tractor

The cab complies with category 2 under EN 15695-1:2009. This category cab ensures protection against dust, but not against sprays and vapor – the tractor shall not be used under conditions, requiring protection against sprays and vapor.

Do not operate the tractor in a closed room without required ventilation. Exhaust gas may result in lethal outcome.

Tractor start-up and operation with the hood opened is not allowed.

It is forbidden to open the hood when the engine is running.

Do not start the engine when staying outside the operator's seat. Starting the engine and manipulating the controls, always stay inside the cab in the operator's seat.

Do not start the engine by way of towing.

Before starting the engine, engage the parking brake, the rear PTO shall be disengaged, the range shifting lever shall be in "Neutral" position.

During tractor start there shall be no people under the tractor, in front of it or behind, as well as between the tractor and the coupled implement or trailer.

Before setting on the move warn people around including those operating the coupled implements using the horn, make sure the parking brake is off and start moving slowly.

Use safety harnesses (supplied against order) at hauling operations.

Passenger staying in the cab during tractor operation is strictly forbidden. (Passenger may stay in the cab only when an additional seat is installed and hauling operations are carried out).

Do not leave the tractor on the move.

Performing hauling operations observe traffic regulations, adopted in your country.

Hauling operations may be carried out by operators with not less than two years of tractor operation experience and those who have passed exams in traffic regulations.

Drive the tractor on slippery roads with automatic DL engaged only at a speed not higher than 10 km/h.

Using the tractor for hauling operations do the following:

- set a track (1530±20) for front wheels and (1800±20) for rear wheels mm.
- check operation of brakes; interlock brake pedals, check and if necessary adjust the brakes for simultaneity of operation;
- check operation of the parking brake;
- check a condition of devices for light and sound annunciation; hauling trailers shall have rigid hitches and be linked with a safety chain or a cable;
- never move downhill with the gear disengaged. Move uphill and downhill at the same gear;

It is forbidden to operate with a trailer without independent brakes, if its weight exceeds a half of a total actual weight of the tractor. The faster you move and the more weight you tow, the bigger safety distance shall be.

It is forbidden to drive the tractor with twinned wheels on public roads!

Hauling people inside trailers is forbidden.

Before getting down to work with a trailer turn the compressor on, check the condition of the trailer brake pneumatic drive and air pressure in the system. Remove the failures detected. Make sure to connect the trailer brake pneumatic drive. Carry out connection of the trailer connecting head to the tractor connecting head with the parking brake engaged.

Do not work under raised agricultural implements. Do not leave implements uplifted when stopping for a long time.

Trailers attached to the tractor shall have a braking system, ensuring:

- trailer brake on movement;
- brake engagement in case of trailer detachment from the tractor;
- holding the trailer when staying on slopes;
- prevention of trailer from pushing the tractor when the travel speed is changed abruptly.

The trailer shall be linked to the tractor by means of a safety chain.

It is required to check operation of the braking system of tractor-trailer train at a speed of 3 to 5 km/h.

The travel speed at access ways and at passways shall not exceed 10 km/h.

Loading (unloading) the trailer engage the parking brake of the tractor.

Driving on public roads turn on a flashing beacon, if available.

Do not stop the tractor on slopes. If there is a necessity to stop the tractor engage the parking brake.

Working on the slopes increase the tractor track to the max.

Working on the slopes with an angle of more than 20° set the max. rear wheel track.

Before exiting the cab disengage the rear PTO, stop the engine, engage the parking brake and remove the key from the starter switch.

If the engine or the steering are broken down, immediately stop the tractor. Keep in mind that with the engine stopped it is required to apply much greater force to the steering wheel to operate the tractor.

In case a failure occurs, immediately stop the tractor and eliminate the fault.

Avoid leakage of electrolyte, coolant, fuel, oil and braking fluid.

Use summer and winter grades of fuel correctly. Fill in the fuel tank at the end of each day to decrease night condensation of moisture. Fill the tractor only with grades of oil and lubricants recommended by the manufacturer. It is strictly forbidden to use other lubricants.

It is forbidden to turn off the system of electrical equipment by means of the battery disconnect switch with the engine running.

Operate the tractor at night-time with lighting devices on and being in good order.

If put to a wrong use, your tractor can be dangerous for you as well as for third persons. Avoid using equipment not intended for installation on the tractor.

Make sure any additional equipment or auxiliary units are mounted correctly and that they are intended to be used with your tractor.

To prevent the tractor from turning over, keep up with the following precaution measures when operating the tractor:

- choose safe speed, corresponding to road conditions, especially when moving cross-country, when crossing ditches, slopes and by sharp turns;
- turn round corners with a speed not higher than 5 km/h, on a slippery road – not higher than 3 km/h.
- move down the hill with first or second gear engaged.

Note – This list of precaution measures is not exhaustive. To avoid turning over, be always careful when operating the tractor.

It is forbidden to use the tractor at works where there is a possibility for the tractor to turn over.

Do not operate the tractor with gauges out of order.

It is not admitted to inflate tires without pressure control.

Coupling the tractor with agricultural implements comply additionally with safety measures concerning use of these implements.

Before coupling the tractor with agricultural implements make sure the automatic grips of the lower and upper links of the RLL are clean and faultless. It is forbidden to operate with the automatic grips out of order, their inner cavities stuffed with dirt and foreign particles.

If the tractor front part rises off the ground when heavy implements are hinged on the mechanism of the rear lift linkage, mount front ballast weights.

Do not work under raised agricultural implements. Do not leave implements uplifted when stopping for a long time.

Before lifting and lowering a hinged agricultural implement and also when turning the tractor make sure there is no danger of catching somebody or stumbling on the hurdle.

The mounted and semi-mounted machine is to be lowered into its operating position and up lifted into the hauling position only with a straight-line motion of the assembly unit.

To avoid breakdown of the tractor or the agricultural implement, drive and turn the tractor assembly with the agricultural implement uplifted only after you make sure the rear PTO are disengaged.

Linking and hinging the agricultural machines and implements on the tractor the rear operator shall stay at a safety distance until the operation is fully stopped. The linkage (hinge) shall be started only after the tractor operator gives a command.

Engaging the rear PTO move the control rod smoothly from "off" position to "on" position, in order to avoid breakdown of the drive shaft, gears of the gear group and the rear PTO end extension.

Linking the machine cardan shaft to the RPTO, disengage the RPTO, stop the tractor by means of the parking brake and stop the engine.

After disconnecting the machines driven by the RPTO, remove cardan drives and cover the PTO end extensions with protective caps.

Cardan shafts, transferring torque from the RPTO of the tractor to the implement working units shall be safeguarded.

Operating with stationary machines, driven by the RPTO, always engage the parking brake and lock the rear wheels at the front and at the back. Make sure the machine is securely fixed.

Make sure the safeguards of the RPTO is mounted and, if the PTO is not used, put back the cap of the PTO shaft end extension.

Do not wear loose clothes when working with the RPTO or near rotating equipment.

To avoid breakdown of the tractor or the agricultural machine, turning the tractor assembly is possible only after the working units of the machine have been fully raised from the ground.

When the tractor assemblies are operating in a column, they shall have an interval not less than 30 m between each other.

Depending on operation conditions use natural ventilation of the cab or the unit of air cooling and heating.

During tractor operation the operator shall use standard means of protection for hearing organs.

In case the tractor assembly is operated or is driven in an area of power transmission lines, a distance between the top of the tractor assembly and wires shall conform to table 3.6.

Table 3.6

Line voltage, kV, up to	11	20-25	110	154-220	330-500
Horizontal distance, m, not less than	1,5	2	4	6	9
Vertical distance, m, not less than	1	2	3	4	6

3.3.2 Fire safety measures

The tractor shall be equipped with fire fighting equipment, i.e. a shovel and a fire extinguisher. Operating the tractor without fire fighting equipment is forbidden.

Never fuel the tractor with the engine running.

Do not smoke when fueling in the tractor.

Do not fuel the tank to the max. Leave some volume for fuel to expand.

Never add petrol or mixtures to engine fuel. This combination may create increased danger of inflammation or explosion.

Places for tractor parking, storing of fuel and lubricants shall have a plowed around band of not less than 3 m width and also be provided with fire extinguishing means.

The tractor must be filled with fuel and lubricants by a mechanic way and with the engine stopped. Use lighting at night time. It is not recommended to fill in tanks using buckets. Carrying out repair operations in field conditions using electric/gas welding, clean parts and assembly units from plant remains.

Prevent the manifold and muffler from getting dirty with fuel, thatch, etc.

Avoid thatch winding around rotating parts of the implements coupled with the tractor.

Washing parts and assembly units with kerosene or gasoline take care to exclude a possibility of inflammation of flushing fluid vapor.

Do not operate the tractor in places subjected to fire risk with the hood and other protective units removed from hot parts of the engine.

Do not use open fire to warm up oil in the engine sump, to fill in fuel tanks, to burn out dirt in a radiator cell.

In case a fire bed occurs, pour some sand onto it, cover with canvas cloth, sack-cloth or other dense texture. Use a dry-powder fire extinguisher. Do not pour water over burning fuel and oil.

Make sure there are no flammable materials near the exhaust manifold and the muffler during engine running.

Harvesting hay and thatch, operating at places with enhanced danger of fire, avoid amassment of inflammable materials on a muffler guard and on gas links.

Performing daily maintenance be sure to do the following operations:

- check the condition of the wiring, wire bundles in the engine compartment, in the cab front area, and the condition of visible parts for abrasion, melt or damage of outer insulation. Should the above faults be discovered, restore the damaged areas using insulation tape and eliminate the cause that has lead to insulation damage;

- review the hydraulic components. If there is steaming and leakage, it shall be eliminated by way of tightening of threaded connections. Faulty high-pressure hoses and pipes shall be replaced.

To avoid burning of tractor wiring never use fuses with current rating higher than rating specified in this subsection 2.20 "Cutout fuses".

It is forbidden to mount wire bridges and other current-conductive components, manufactured by rule of thumb instead of cutout fuses.

Turn the power disconnect switch off when finishing to operate the tractor.

3.4 Tractor final assembly and run-in

3.4.1 Tractor final assembly

The "BELARUS-1025.5" tractors are supplied to a consumer ready assembled, final assembly is not required.

3.4.2 Technical maintenance before tractor run-in

Before placing a new tractor in operation do the following:

- wash the tractor, remove preservative lubricant (if any on the tractor);
- carefully inspect the tractor, check it for completeness and availability of instruction manuals;
- remove accumulator battery, set it into working condition and mount back;
- check outer threaded joints for tightness and tighten if necessary;
- check oil level in the engine oil sump, in the transmission, in FDA case, in cases of FDA wheel gear groups, in HLL and HSC oil tanks and, if necessary, add as per section 5 "Maintenance";
- drain the available fuel from the fuel tank and fill the fuel tank with new settled fuel: in winter – winter grade, in summer – summer grade;
- fill the engine cooling system with coolant up the upper edge of the radiator filler neck, fill the expansion tank with coolant till it occupies half of the tank volume.
- check and if necessary adjust the tire pressure to a desired value in accordance with subsection "Selection of optimal inner pressure in tires depending on operational conditions and load on tractor axles".
- make sure there are protective guard shields (for RPTO etc.);
- check engine running, operability of lighting and warning devices, action of brakes and steering control, and also check functioning of the other systems and units of the tractor over on-board control gauges;

Before starting to run in, check tightness of bolts attaching the hubs (the tightening torque for the bolts attaching terminal hubs of rear wheels shall make 300 to 400 Nm, the tightening torque for the bolts attaching taper hubs shall make 360 to 400 Nm), tightness of the nuts attaching rear wheels to the hub (the tightening torque shall make 300 to 350 Nm), the nuts attaching front wheel plates to FDA gear group flanges (the tightening torque shall make 200 to 250 Nm) and the nuts attaching front wheel plates to rim brackets (the tightening torque shall make 180 to 240 N·m).

3.4.3 Tractor run-in

ATTENTION: THE FIRST 30 HOURS OF TRACTOR OPERATION HAVE GREAT INFLUENCE ON OPERATIONAL PARAMETERS AND LIFE SPAN OF THE TRACTOR. YOUR TRACTOR WILL FUNCTION PROPERLY FOR A LONG TIME PROVIDING YOU CARRY OUT THE RUN-IN CORRECTLY AND PERFORM OPERATIONS IN TECHNICAL MAINTENANCE IN TERMS SPECIFIED IN SECTION 5 "MAINTENANCE SERVICES"!

ATTENTION: IT IS OBLIGATORY THAT YOU CARRY OUT TRACTOR RUN-IN FOR 30 HOURS! LOAD THE TRACTOR UP TO 80 % OF ITS RATED POWER BEFORE THE FIRST TECHNICAL MAINTENANCE (TM-1) (125 HOURS)!

Start the engine. Let the engine run at idle speed for five minutes with gradual increase of the rotation speed up to 1600 rpm, then run in under the load for 30 operation hours.

Carrying out the 30-hour run-in follow the below instructions:

- constantly inspect gauge indications, operation of lubrication system, cooling system and power supply system. Control levels of oil and fluids in refill capacities;
- check outer fastening links for tightness and tighten them;
- do not overload the engine, avoid engine smoking and speed decrease. The features of overload are sharp decrease of speed, smoking and absence of engine reaction to increase of fuel feed. Operation at high gear under load results in excessive wear of friction parts of the engine;
- tractor operation at lower gear under small load and with increased speed of the engine will result in fuel overconsumption. Right selection of the gear for each specific condition of operation ensures fuel economy and reduces engine wear-out;
- avoid prolonged engine operation without load in a mode of max. or min. speed of the engine;
- for correct break-in of the clutch friction parts during the run-in process engage the clutch more often and more smoothly.

3.4.4 Technical maintenance during tractor run-in

After the first operation hour check tightening of nuts attaching rear wheels to the hub, nuts attaching front wheels to FDA gear group flanges and nuts attaching the front wheel disks to the rim brackets. Then inspect the wheel tightening every eight hours during the run-in.

In the run-in process regularly carry out operations in shift-time technical maintenance according to the instructions, set forth in section 5 "Maintenance services" of this manual.

3.4.5 Technical maintenance after tractor run-in

After the tractor run-in do the following:

- perform shift-time maintenance operations;
- inspect and wash the tractor, clean the cab;
- listen to the operation of all tractor constituents;
- check tightening of nuts attaching rear wheels to the hub, nuts attaching front wheels to FDA gear group flanges and nuts attaching the front wheel disks to the rim brackets;
 - tighten two lock nuts M27x1,5 (with left and right thread) of the steering link tube with a torque of 100 to 140 N·m and two crown nuts M20x1,5 of the steering link ball pins. To tighten the crown nuts, remove the cotter pin first, tighten each crown nut with a torque of 100 to 140 N·m, then turn each crown nut until the nearest notch on the nut coincides with a hole in the ball pin and then fasten with a cotter pin.
- check and if necessary tighten outer threaded links;
- drain condensate from the pneumatic system receivers;
- drain sediment from fuel tanks and the engine coarse filter;
- check the state of accumulator batteries, clean terminal connections and ventilation holes;
- check and if required adjust free movement of the clutch pedal, of the working and parking brakes control and brake valve drive of pneumatic system;
- drain oil from the transmission. Then clean the rotor of the gearbox centrifugal oil filter and the gearbox net filter. Fill the transmission with new oil;
- replace oil in the housings of wheel-hub drives and FDA housing;
- replace oil in the engine crankcase;
- replace oil filter of the engine;
- check and if required tighten the bolts attaching cylinder heads;

- check and if required adjust clearance between the valves and rockers arms;
- replace oil in the housings of the wheel gear groups and in the FDA housing;
- check lubrication in all assembly units according to clause 3 of table 5.4. Where required lubricate or replace the lubricant;
- check and if necessary restore hermiticity of the air cleaner and inlet line;
- control engine running, steering, brakes, operation controls, lighting and warning systems;

3.5 Emergency actions

3.5.1 To stop the tractor immediately, sharply depress clutch and brake pedals.

3.5.2 For emergency stop of the engine turn the key of the starter and instrument switch from “I” position to “0” position according to the diagram provided in figure 2.2.2.

3.5.3. In case of an accident immediately stop the engine, engage tractor brakes, deactivate accumulator batteries and get off the tractor through one of emergency exits, having opened left or right cab door, depending on the tractor position, or rear screen, or one of lateral screens. To open the lateral screens it is required to move the screen opening handle to an operating condition (operating condition – screen opened), then press this handle in the direction, which is contrary to the tractor forward motion, until the guide pin fully comes out from the handle, and then open the screen completely. If it is not possible to open the emergency exits, break the screen of one of the emergency exits with a heavy subject at hand and leave the tractor cab.

Note – Emergency exit allocation is given in subsection 2.21 “Cab locks and handles”.

3.5.4 In case the engine crankshaft speeds up excessively, kill the engine and brake the tractor immediately.

3.5.5 In case a fire bed occurs, stop the engine, brake the tractor, turn off the accumulator battery switch. Pour some sand onto the fire bed, cover with canvas cloth, sack-cloth or other dense texture. Use a carbon-dioxide fire extinguisher. Do not pour water over burning fuel and oil.

4 COUPLING OF IMPLEMENTS

4.1 General information

In section 4 "Coupling of implements" necessary instructions and data on features of application of tractor "BELARUS -1025.5" are given.

Permitted field of application of tractor "BELARUS-1025.5" includes places with unrestricted air exchange, sufficient flotation and overall passing ability.

Tractors "BELARUS-1025.5" are designed for performance of the mechanized works in plant growing and fodder production.

Tractors "BELARUS-1025.5" are packaged with necessary work equipment for coupling of implements i.e. lift linkage and drawbar hitches, PTO, hydraulic feed-outs, pneumatic heads and electrical outlet receptacles. The tractor implements listed above allow coupling of implements of various machines in structure of MTU (machine and tractor unit or tractor-mounted units).

ATTENTION: TRACTORS "BELARUS-1025.5" ARE DESIGNED FOR COUPLING OF MOUNTED, SEMI-MOUNTED, SEMI-TRAILED AND TRAILED IMPLEMENTS IN STRUCTURE OF MTU ONLY, TECHNICAL CHARACTERISTICS OF WHICH, RELATED TO ABILITY TO BE COUPLED, ARE COMPARABLE TO TRACTOR SPECIFICATIONS! OTHER APPLICATION OF TRACTOR IS NOT ALLOWED!

Selection and buying of agricultural implements (fertilizer distributors, plungers, motor cultivators, harrows, seeding machines, rotary tooling and other implements) for tractors "BELARUS-1025.5" is carried out by the customer itself according to its needs, and with consideration of the implement and tractor performance specifications, and also local conditions i.e. agrotechnical requirements, soil conditions, personal experience, guidelines of corresponding regional advisory centers and institutions for agricultural industry.

ATTENTION: GUIDELINES AND DATA ON SPECIFIC ASPECTS OF USAGE OF IMPLEMENTS WITH A TRACTOR AND DATA ON THE RECOMMENDED TRACTOR PERFORMANCE SPECIFICATIONS ARE PRESENTED IN OPERATIONAL DOCUMENTATION FOR IMPLEMENTS COUPLED!

Possibilities of agricultural tractors applications in the specified use environment are limited by tolerance range of force, exerted on hook rating and engine power, tractor maximum permissible load, roadhold of chassis, frictional sliding, operation driving speed, size power take-off value and operating weight of the implements coupled.

ATTENTION: WHILE OPERATING TRACTOR IN STRUCTURE OF MTU IT IS REQUIRED TO STUDY AND FOLLOW THE INSTRUCTIONS SET FORTH IN THE OPERATIONAL DOCUMENTATION OF IMPLEMENTS COUPLED WITH A TRACTOR CAREFULLY! PERSONNEL NOT HAVING STUDIED DOCUMENTATION AND SAFE MACHINE OPERATING PROCEDURES, AND HAVING NO DOCUMENTS ON-SITE, IS NOT ALLOWED!

ATTENTION: WHEN COUPLING OF MOUNTED, SEMI-MOUNTED, SEMI-TRAILED AND TRAILED IMPLEMENTS WITH TRACTORS "BELARUS-1025.5", INSTALLATION OF AUTOMATED CONTROL SYSTEMS, BEING THE PART OF THE MACHINE KIT, FOR TRACING OF OPERATIONS SEQUENCE IN THE CABIN, AND ITS CONNECTION TO THE BOARD NETWORK IS ALLOWED IF IT IS PROVIDED FOR IN THE OPERATIONAL DOCUMENTS FOR THE IMPLEMENTS.

Tractors "BELARUS-1025.5" belong to the category of motor vehicles covered by traffic regulations proceedings and other regulatory documents on the operation of off-track vehicles.

Tractor operator is personally liable for abidance by traffic regulations and safe operation requirements, and safety measures and correctness of tractor "BELARUS-1025.5" operation, set forth in this operation manual.

Service staff qualification requirements for tractor “BELARUS-1025.5” operation:

- only qualified personnel that is aware of safety arrangement and precautions matters, having license documents of due form, determined by the legislation for tractor driving and having got admission to operate certain tractor, is allowed.
- if tractor owner (or any person liable for tractor operation) does not operates tractor himself, he must ensure that before starting operations all persons related to the tractor have been duly instructed on safety operation requirements and on correct coupling of implements with the tractor, and have studied the operation manual for the tractor enclosed.

ATTENTION: OWNERS AND OFFICIALS OR OTHER PERSONS MUST NOT ALLOW THE TRACTOR FOR ROAD TRAFFIC AND COUPLING WITH IMPLEMENTS, OR ADMIT OPERATORS FOR DRIVING THE TRACTOR IN CONTRAVENTION OF CURRENT TRAFFIC REGULATIONS AND THE PRESENT OPERATION MANUAL!

ATTENTION: BEFORE STARTING THE TRACTOR IN STRUCTURE OF MTU ENSURE THAT THERE IS NO PEOPLE IN CLOSE VICINITY TO THE TRACTOR INCLUDING THE AREA BETWEEN THE TRACTOR AND IMPLEMENTS OR TRAILERS (SEMI-TRAILERS) COUPLED!

4.2 Types of implements coupled with tractor “BELARUS-1025.5”

According to the type of coupling with tractors «BELARUS-1025.5» the implements are divided into the following types:

- mounted implement is fixed in three points to the upper and lower draft arms of LL. The tractor can carry weight of an implement in full. Implement structural components at carry is not in touch with ground contact area. While changing the implement position from operating to transport the point in which the implement is connected to the tractor is forcedly displaced to the new point along the full vertical extent;

- semi-mounted implement is fixed in three points to the upper and lower draft arms of LL or just in two points to the upper and lower draft arms of LL only. The tractor can carry weight of an implement in part and mostly by its traveling wheels (usually by one or two wheels). While changing the implement position from operating to transport, the point in which the implement is connected to the tractor is forcedly displaced to the new point along the full vertical extent. Two-point articulated linkage is effected by way of connection of suspension axis link pin to the lower draft arms hinges of LL (upper draft arm is not used). It is also possible to use a cross arm from the tractor or implement kit.

- semi-trailed implement is usually fixed in one point by means of tractor drawbar clevis to the DH. It is also possible to use a two-point connection with lift linkage (upper draft arm is not used). The tractor can carry weight of an implement in part and mostly by its traveling wheels (usually not less than by two). While changing the implement position from operating to transport, position of the point in which the implement is connected to the tractor remains unchanged. Semi-trailed implements include various vehicles for general and special purposes: general purpose semi-trailers, tank semi-trailers and dampers, and special purpose semi-trailed vehicles for mechanizing of technological process in the agricultural sector.

- traileed implement is usually fixed in one point by means of tractor drawbar clevis to the DH. It is also possible to use a two-point connection with lift linkage (upper draft arm is not used). The chassis can carry weight of an implement in full, hitch mechanism (DH or LL) is loaded only by weight of implement connector. While changing the implement position from operating to transport, position of the point in which the implement is connected to the tractor remains unchanged. Semi-trailed implements include various vehicles for general and special purposes: general purpose semi-trailers, tank semi-trailers, and dampers, and special purpose semi-trailed vehicles for mechanizing of technological process in the agricultural sector.

4.3 Rear lift linkage

4.3.1 General information

ATTENTION: BEFORE LEAVING THE TRACTOR FOR ANY TIME PERIOD, THE LINKED IMPLEMENT SHALL BE PUT ON THE GROUND INDISPENSABLY!

ATTENTION: MAXIMUM LIFTING POWER VALUE OF LIFT LINKAGE AT THE SUSPENSION AXIS DETERMINATES TECHNICAL OPERABILITY OF THE LIFT LINKAGE, BUT NOT PERMISSIBLE MASS OF THE IMPLEMENT COUPLED THROUGH IT. PERMISSIBLE MASS OF THE IMPLEMENT DEPENDS ON THE CENTROID OVERHANGING LENGTH AGAINST THE SUSPENSION AXIS, AND IT IS LIMITED BY PERMISSIBLE LOADS ON THE TRACTOR AND BY CONTROLLABILITY CRITERION!

Rear lift linkage corresponds to the requirements of ISO 4254-3.

4.3.2 Three-point rear lift linkage

Three-point rear lift linkage of "BEARUS-1025.5" is made according to State Standard GOST 10677 and ISO 730. Basic parameters of RLL, specified in Table 4.1 and in Figure 4.3.1, parameters are given with standard rear tires (18.4R34 both single and doubled), mounted to the tractor and with standard static radius, specified by the manufacturer.

Rear lift linkage consists of three links (upper one and two lower links) with front ends articulated via hinged joint with the tractor, and with rear ends articulated with free hinged joint for the purpose of connection to the attachment pins of the implements coupled. RLL is designed for connection of implements for tail positioning to a tractor, for link power transfer during operation and adjustment of their position during operation, or run at transport position. RLL provides for coupling of the following types of implements and instruments:

- mounted implement fixed in three points (upper one and lower links);
- semi-mounted (lower links);
- semi-mounted with a cross arm to the suspension axis of lower links.

ATTENTION: MOUNTING OF A CROSS ARM OR TRAILING SUSPENSION AXIS, BEING THE PART OF IMPLEMENTS SET FOR COUPLING OF SEMI-MOUNTED, SEMI-TRAILED AND TRAILED IMPLEMENTS FOR FULFILLMENT OF DIFFERENT WORKS WHEN SPEED DOES NOT EXCEEDS 15 KM/H, TO THE ENDS OF LOWER LINKS OF REAR LIFT LINKAGE!

Sizes and structure of RLL of tractors "BELARUS-2022.5" make it possible to couple all implements, having the corresponding dimensions of attachment elements of connection triangle shown in RLL diagram

Rear lift linkage diagram of type "LL-2" is shown in Figure 4.3.1.

For protection of coupled implements from rocking length adjustable limit external rods are used.

To ensure the implement is in the right position the following adjustments of RLL by means of upper link, crossbeams and limit rods are provided in vertical and horizontal plane:

1 Modification of length of upper link

It is carried out in order to ensure penetration of operative parts (alignment of running depth of operative parts located one after another along the tractor run). If mounted plough carriage reaches forward along the tractor run and the front plough body cuts deeper than the rear one, extend the upper link; and if the front plough body cuts for the more shallow depth than the rear one, the upper link shall be shortened.

2 Modification of length of left or right crossbeam.

The modification is carried out in the following cases:

- to ensure the implement is in the horizontal plane;

- to ensure the even depth processing with operative parts of tractor-mounted machine across the width of cut;

3 Modification of length of both crossbeams, upper link for transport position of the implement.

The modification is carried out in the following cases:

- to ensure the necessary road clearance;
- to ensure the sufficient safe clearance between the elements of the tractor and the implement, excluding the contact of parts of the tractor implements (clearance is not less than 100 mm).

4. Modification of length of both tension rods.

The modification is carried out in the following cases:

- during transportation of the implement, tension rods shall be blocked for the limitation of the implement rocking at run for the avoidance of the tractor elements damaging in case of an incidence;

- during operation of mounted, semi-mounted tilling machines with passively operated parts for the full processing (share and chisel ploughs, shallow ploughs, rippers and other implements), free movement in horizontal plane (rocking) shall be ensured, and the fasteners shall be unblocked”;

IT IS FORBIDDEN TO OFFSET THE LONGITUDINAL AXIS OF THE IMPLEMENT, CONCERNING THE LONGITUDINAL AXIS OF THE TRACTOR BY MEANS OF ADJUSTMENT OF TENSION RODS.

ATTENTION: LENGTH OF THE LEFT CROSSBEAM OF THE REAR LIFT LINKAGE MAKES 585 MM, WHICH SHALL NOT BE CHANGED WITHOUT PARTICULAR NEED. IT IS USUALLY THE RIGHT CROSSBEAM THAT IS LENGTH ADJUSTABLE. WHEN THE CROSSBEAM IS USED ON THE SUSPENSION AXIS AND WHEN REVERSIBLE PLOUGH IS USED THE LENGTH OF CROSSBEAMS SHALL BE ALL THE SAME!

ATTENTION: NONCOMPLIANCE WITH THE REQUIREMENTS FOR ADJUSTMENT OF FASTENERS AND CROSSBEAMS MAY RESULT IN FASTENERS OR SUPPORT BRACKET BREAK OR OTHER BREAKAGE!

ATTENTION: ESSENTIAL FEATURES AND WAYS OF ADJUSTMENT OF POSITION OF THE IMPLEMENT COUPLED WITH MOUNTED DEVICES ACCORDING TO THE PECULIARITIES OF TECHNOLOGICAL PROCESS EXECUTION AND AGRO-TECHNICAL REQUIREMENTS ARE SPECIFIED IN OPERATIONAL DOCUMENTATION OF SUCH IMPLEMENTS. IF THERE IS NO INFORMATION IN OPERATIONAL DOCUMENTATION, YOU SHALL OBTAIN IT FROM THE MANUFACTURER OR SELLER OF THE IMPLEMENT!

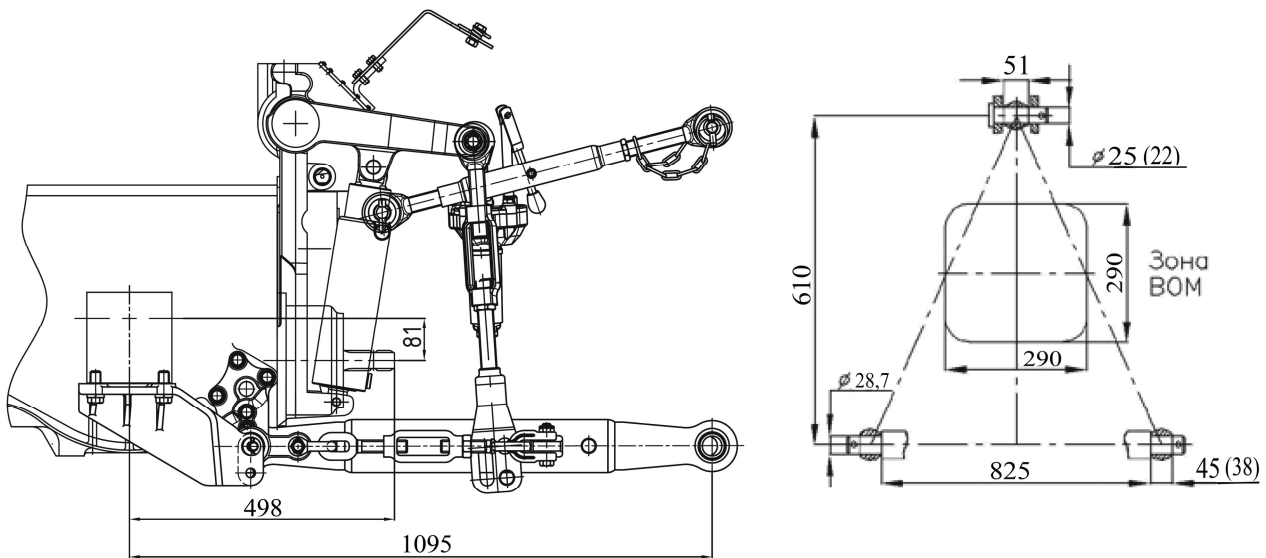

Figure 4.3.1 – Rear lift linkage diagram of “LL-2” type

Table 4.1 – Basic parameters and coupling dimensions of RLL

Standard size (configuration) of the device	LL-2 (Figure 4.3.1)
1 Category (acc. to ISO 730-1)	Category 2
2 Design features	Device consisting of three links (upper one and two lower ones), pivot-connected with the tractor; coupling elements of the implement during operation free ends of links with hinge pivots are coupled during implement coupling with the implement's elements coupled
3 Purpose	To connect (mount) or coupling of mounted, semi-mounted implements
4 Lower links	Solid
5 Length of lower links, mm	885
6 Hinged joint width of the upper (lower) link, mm	51 (45) acc.to ISO 730-1 51 (38) acc.to GOST 10677
7 Diameter of a pin of a rear-end hinged joint of the upper link, mm	25 acc.to ISO 730-1 22 acc.to GOST 10677
8 Diameter of holes in rear hinge joints of lower links, mm	28,7
9 Distance between PTO shaft end extension face and suspension axis, mm	597
10 Column height 1), mm	610
11 Length of the suspension axis along the shoulders 1), mm	825
12 Lifting power of the device, kN: a) on the suspension axis; b) at overhang of 610 mm from the suspension axis	42 27
1) Dimension refers to the implement coupled. 2) It is not allowed to give RLL load exceeding loading of tires specified by loading instructions set forth in subsection "Selection of optimal inner pressure in tires depending on operational conditions and load on tractor axles"	

4.3.3 RLL components adjustment rules

4.3.3.1 Buckles

4.3.3.1.1 General information

Buckles are used to limit side sway of lower links of the lift linkage both in transport and in operating position. Your tractor can be equipped with telescopic buckles or outer turnbuckles.

ATTENTION: IN CASE OF CHANGE OF LENGTH OF A LIFTING ROD IT IS NECESSARY TO ADJUST BUCKLE LOCKS AGAIN IN TRANSPORT AND OPERATING POSITIONS. NON-FULFILLMENT OF THIS REQUIREMENT MAY RESULT IN BREAK OF LIMIT BUCKLES OR OTHER DAMAGE!

4.3.3.1.2 Telescopic buckles

Back end of telescopic buckle 1 (Figure 4.3.2) is connected to the lower link 2, and front end – is connected to bracket 3.

ATTENTION: IN ORDER TO AVOID DAMAGE TELESCOPIC BUCKLES OF TRACTORS “BELARUS-1025.5” SHALL BE MOUNTED ONLY ON THE SECOND-FROM-THE-BOTTOM BORES IN BRACKETS (POSITION 2 IN FIGURE 4.3.3)! USE OF POSITIONS 1, 3 AND 4 ON THE BRACKET SHOWN IN FIGURE 4.3.3 IS FORBIDDEN!

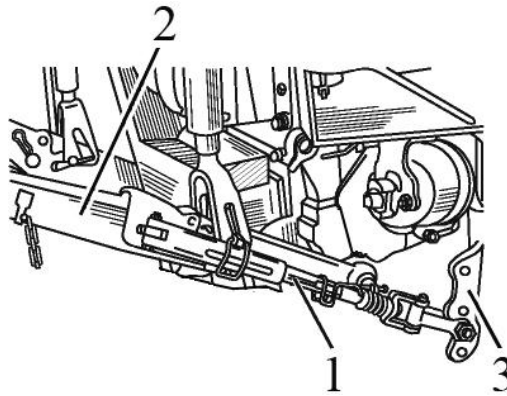

1 – telescopic buckle; 2 – lower link; 3 – bracket.

Figure 4.3.2 – Telescopic buckles assembly

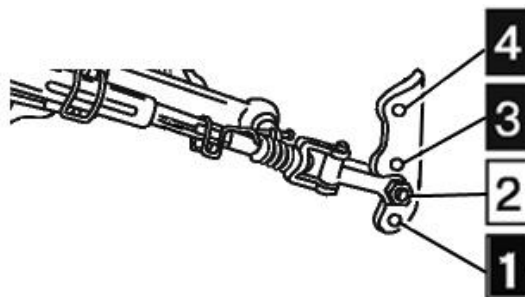

Figure 4.3.3 – Mounting of buckle back end into the bracket

During tractor operation the telescopic buckles must always be blocked in one of the three available positions:

- partial blocking of buckles in operating position;
- full blocking of buckles in operating position;
- full blocking of buckles in transport position.

During operation with some implements it is necessary to provide swaying of the implement in each side for not less than 125 mm or other interval in compliance with the machine (implement) operation manual. For this purpose, buckles should be partially blocked.

Partial blocking of buckles in operating position should be made in the following way:

- turning screw 2 (Figure 4.3.4), set handle 3 in the middle of flattened surface "A";
- derive forelock key 5 from the buckle;
- attach the machine (implement) to the lower links 7 and lift it a little bit until it takes off from the ground;
- set the machine (implement) symmetrically to the tractor longitudinal axis;
- match the bores in the inner pipe 4 with a nearest hole in the outer pipe 6, insert forelock key 5 into the nearest bore to the middle of the bore in the inner pipe 4;
- adjust forelock key 5 position by turning screw 2 with handle 3 so that the forelock key comes to the middle of the hole in the outer pipe 6.

ATTENTION: MOUNT FORELOCK KEY 5 (FIGURE 4.3.4) IN SUCH WAY AS IT IS POSITIONED IN THE MIDDLE OF THE HOLE OR WITH MINIMUM DISPLACEMENT TOWARDS THE TRACTOR. OTHERWISE, BUCKLES CAN BE DAMAGED!

During interspace cultivation, seeding time and other types of operations, lower links of the lift linkage must be totally blocked against cross-travel to avoid damages of plants by swinging implement. To do this block buckles in operating position.

Full blocking of buckles in operating position shall be made as follows:

- turning screw 2 (Figure 4.3.4), set handle 3 in the middle of flattened surface "A";
- derive forelock key 5 from the buckle;
- attach the machine (implement) to the lower link 7 and lift it a little bit until it takes off from the ground;
- set the machine (implement) symmetrically to the tractor longitudinal axis;
- turn inner pipe 4 by hand to place its bores in the upper part of the pipe;
- match the bores in the inner pipe 4 with a nearest hole in the outer pipe 6 and insert forelock key 5 into them;
- check side-sway range of the machine (implement), it shall not exceed 20 mm in each side;
- adjust side-sway range of the machine (implement), when necessary, by turning screw 2.

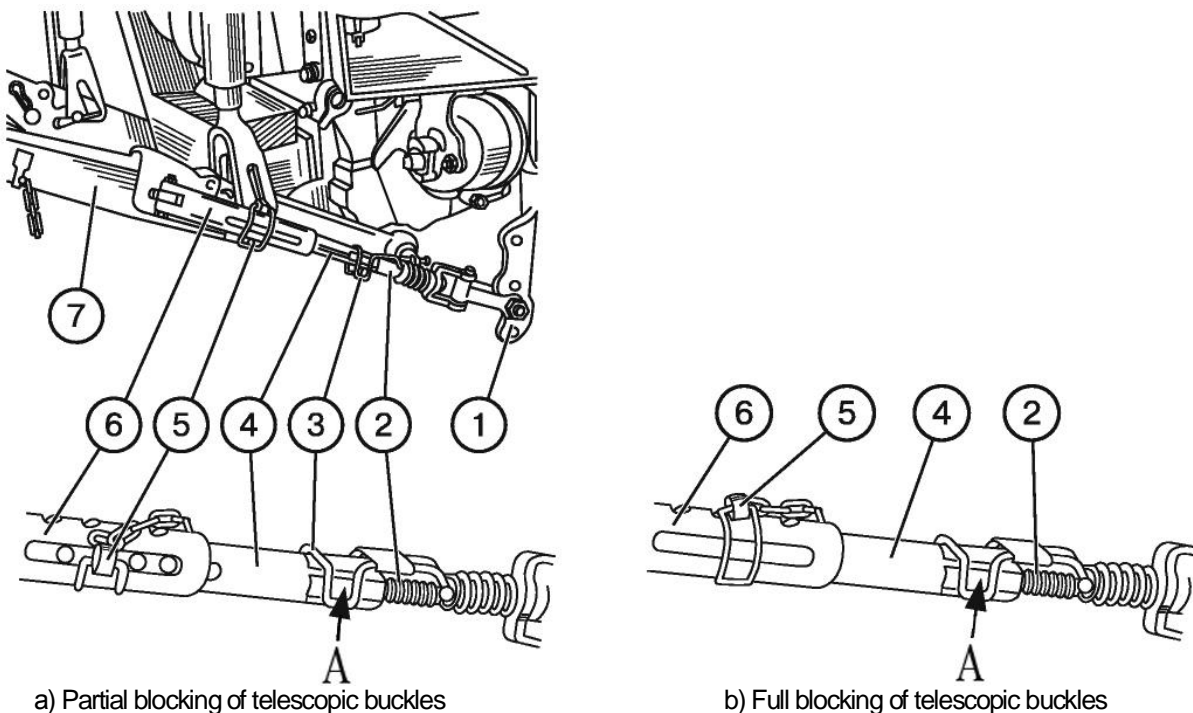

1 – bracket; 2 – screw; 3 – handle; 4 – inner pipe; 5 – forelock key; 6 – outer pipe; 7 – lower link.

Figure 4.3.4 – Partial or full blocking of telescopic buckles

When mounting the RLL in transport position it is necessary to make full blocking of buckles in transport position.

Full blocking of buckles in transport position shall be made as follows:

- if buckles were fully blocked in operating position, you should check side-sway range of the machine (implement) while it is lifted in up position, which shall not exceed 20 mm in each side. Adjust buckle length when necessary, by turning screw 2 with handle 3;
- if buckles were partially blocked in operating position, you should make full blocking first as stated above. After doing so, check side-sway range of the machine (implement) while it is lifted in up position, which shall not exceed 20 mm in each side. Adjust buckle length when necessary by turning screw 2 with handle 3.

4.3.3.1.3 Turnbuckles

During tractor operation outer turnbuckles must always be blocked in one of the three available positions:

- partial blocking of turnbuckles in operating position;
- full blocking of turnbuckles in operating position;
- full blocking of turnbuckles in transport position.

Partial blocking of turnbuckles in operating position shall be made as follows:

- attach the machine (implement) to the lower links and lift it a little bit until it takes off from the ground;
- set the machine (implement) symmetrically to the tractor longitudinal axis;
- turnbuckles must be attached to the lower bores of brackets 1, as is shown in view a) of Figure 4.3.5;
- to achieve swinging of the implement for not less than 125 mm in each side or in accordance with machine operation manual, adjust turnbuckles 2 length by turning central element A of the brace rods.

ATTENTION: ADHERE STRICTLY TO MACHINE SWING RATE OF NOT LESS THAN 125 MM IN ORDER TO AVOID TURNBUCKLES TENSION FRACTURE WHEN THE MACHINE IS LIFTED TO TRANSPORT POSITION!

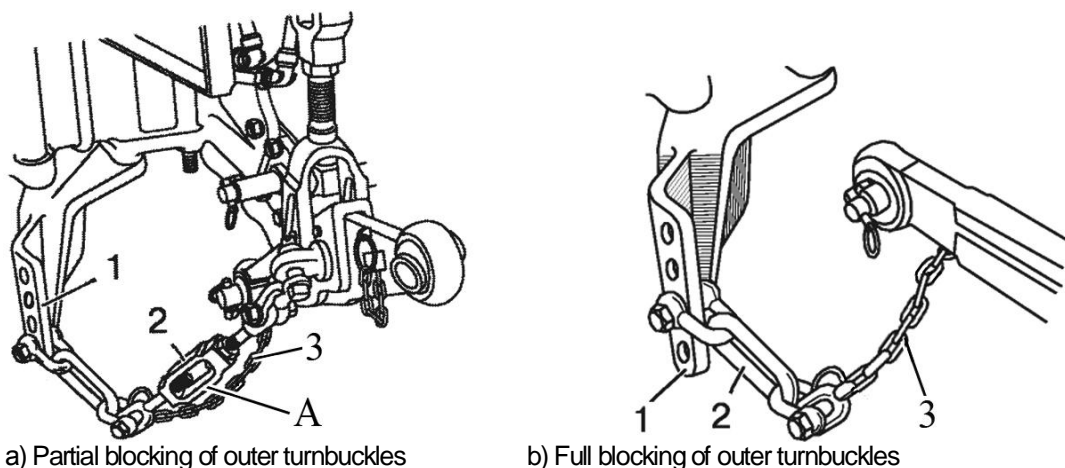

1 – bracket; 2 – turnbuckle; 3 – limiting chain.

Figure 4.3.5 – Partial and full blocking of outer turnbuckles

Full blocking of turnbuckles in operating position shall be made as follows:

- attach the machine (implement) to the lower links and lift it a little bit until it takes off the ground;
- set the machine (implement) symmetrically to the tractor longitudinal axis;
- the turnbuckles must be attached to the second lower bores of brackets 1, as is shown in view b) of Figure 4.3.5;
- check side-sway range of the machine (implement), it shall not exceed 20 mm in each side;
- to limit swinging of the implement in each side for not more than 20 mm, adjust the turnbuckles length 2 by turning central element A of the turnbuckles.

During mounting of RLL in transport position it is necessary to make full blocking of the turnbuckles in transport position.

- if the turnbuckles were partially blocked in operating position, than in up position of the machine (implement) it is required to shorten the turnbuckles 2 length as much as possible by turning of the central element A. After doing so, check side-sway range of the machine (implement) while it is lifted in up position, which shall not exceed 20 mm in each side. Adjust the turnbuckles 2 length when necessary, by turning central element A of the turnbuckles;

- if the turnbuckles were fully blocked in operating position, than in up position of the machine (implement) turnbuckles blocking is provided automatically.

ATTENTION: IF OUTER TURNBUCKLES ARE INSTALLED ON A TRACTOR YOU MUST NOT USE TWO UPPER BORES OF BRACKET 1 (FIGURE 4.3.5).

4.3.3.2 Lifting rod

The tractor can be equipped with two types of lifting rods: screw lifting rod and gear lifting rod.

One of the three configurations of lifting rod pairs can be installed on order:

- two gear lifting rods;
- one gear lifting rod (on the right side in the direction of tractor travel) and one screw lifting rod;
- two screw lifting rods.

The screw lifting rod is shown in Figure 4.3.6.

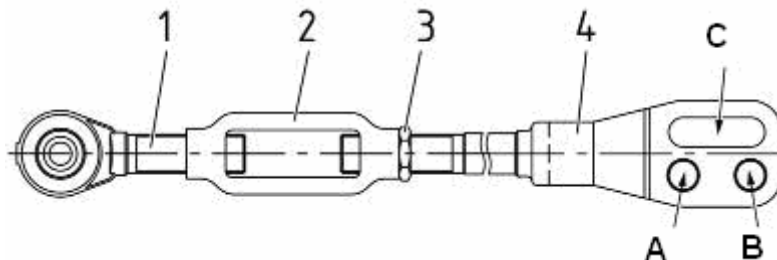

1 – screw with hinge pivot assembly; 2 – buckle; 3 – check nut; 4 – yoke.

Figure 4.3.6 – Screw lifting rod

Adjustment of screw lifting rod length shall be made as follows:

- turn back check nut 3;
- turning buckle 2 clockwise or counterclockwise change the lifting rod length;
- having adjusted the lifting rod length, locknut screw coupling by check nut 3.

The gear lifting rod is shown in Figure 4.3.7.

Adjustment of gear lifting rod length shall be made by turning handle 5 clockwise or counterclockwise.

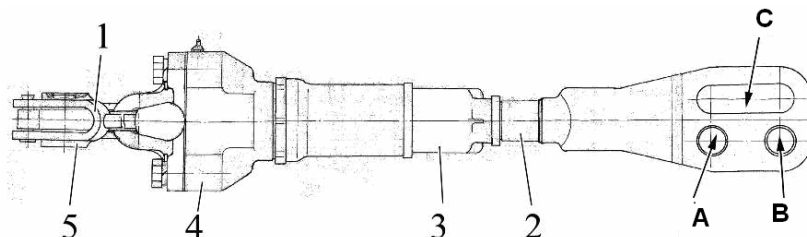

1 – handle; 2 – yoke; 3 – pipe; 4 – case; 5 – clevis.

Figure 4.3.7 – Gear brace

The lifting rod length (both screw lifting rod and gear lifting rod) may be adjusted in the range from 540 to 625 mm. During ex-works dispatch the lifting rods are adjusted to the length of 585 mm.

To accelerate adjustment of the lifting rod length two bores (A and B in Figures 4.3.6 and 4.3.7) are provided on its yoke for pin installation. To copy the contour of processed field during operation with wide-cut implements and to avoid lifting rod damage, connect the lifting rods with lower links using holes (B in Figures 4.3.6 and 4.3.7). The lifting rod yoke holes must be located behind the bore as to the direction of tractor travel in order to avoid lifting rod damage.

During implements operation adjust length of the right lifting rod according to the processing depth.

4.3.3.3 Upper link

Upper link is shown in Figure 4.3.8.

Length of the upper link may be adjusted in the range from 500 to 740 mm.

Adjustment of the upper link length shall be made as follows:

- turn back check nut 4 (Figure 4.3.8);
- turning handle 3 of pipe 2 clockwise or counterclockwise change the upper link length;
- having adjusted the link length, locknut screw coupling by check nut 4.

Use pin 6 of rear hinge pivot for connection of upper link with the implement, fix the pin by forelock key with ring 7.

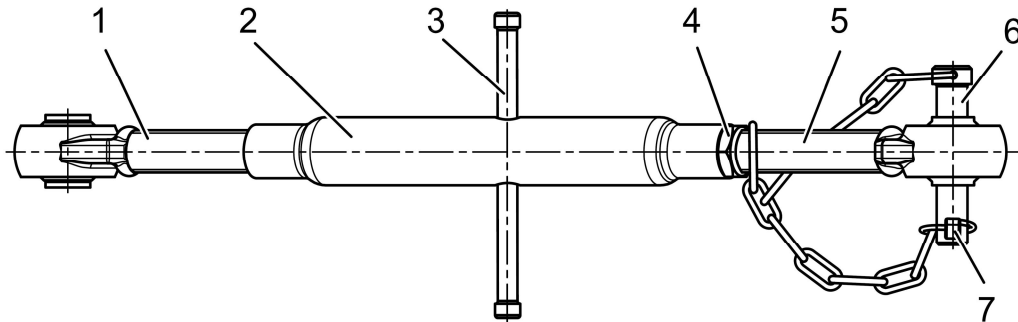

1 – front screw with hinge pivot assembly; 2 – pipe; 3 – handle; 4 – check nut, 5 – rear screw with hinge pivot assembly; 6 – pin; 7 – forelock key with ring.

Figure 4.3.8 – Upper link

4.3.4 Attachment of implements to a tractor

During attachment of implements to a tractor, ensure that there are no people in the area of implement attachment. Using RLL controls put down lower links up to the required level and connect lower links hinge pivots with the implement and then connect upper link hinge pivot by means of a pin. Use right lifting rod to adjust the implement position in transverse plane. To make adjustments in fore-and-aft plane for alignment of depth of front and rear working attachments of the implement change upper link length by turning link pipe to the corresponding direction.

Final adjustment of the machine shall be made in the field.

Before starting operation, ensure that:

- tractor parts are not in dangerous closeness to implement components;
- upper link does not touch PTO guard with the implement in lower position;
- cardan drive from PTO is not abnormally long, with bigger joint angles and that there is no thrust force;
- PTO guard does not touch machine cardan drive guard;
- lift the implement slowly and check availability of clearances between tractor and implement in up position;
- check availability of the required side oscillation of lower links and adjust by means of buckles, when necessary.

WARNING: SOME TYPES OF MOUNTED OR SEMI-MOUNTED IMPLEMENTS CAN TOUCH THE CAB AND DAMAGE IT. IT CAN RESULT IN DAMAGE OF THE CAB WINDOWS AND CAUSE INJURY TO THE OPERATOR. CHECK AVAILABILITY OF CLEARANCES (NOT LESS THAN 100 MM) BETWEEN UPLIFTED IMPLEMENT AND OPERATOR'S CAB!

Mount machines (implements) on a tractor by means of automatic coupler CA-1, connected to the tractor lift linkage in three points (two rear hinge pivots of lower links and rear hinge pivot of upper link).

4.4 Drawbar hitches

4.4.1 General information

Drawbar hitches of "BELARUS-1025.5" can be packaged with drawbar hitches DH-2V (short towing yoke), DH -3V (long towing yoke), DH -2R (python), DH -1 (cross-beam) and DH -1M-01(draw bar), ensuring coupling and transporting of trailed and semi-trailed implements coupling devices of which correspond to the following requirements:

- compatibility according to the coupling dimensions;
- implements are equipped with rigid drawbar hitch;
- draft poles are equipped with a device making the procedure of coupling/uncoupling with drawbar hitch of a tractor easier;
- drawbar hitches of semitrailers have an adjustable support.

Tractor "BELARUS - 1025.5" has special-purpose rear mounting device of lift type in the form of guide plates with several borings fixed to the rear joint face of a rear axis body. The device is meant for mounting of drawbar hitches and allows height adjustment of DH-2V (short towing yoke), DH-2R (python) and DH-3V (long towing yoke).

Installation variants scheme of DH-2V (short towing yoke) is shown in Figure 4.4.1.

Installation variants scheme of DH-3V (long towing yoke) is shown in Figure 4.4.2.

Installation variants scheme of DH-2R (python) is shown in Figure 4.4.3.

Installation scheme of DH-1M-01(draw bar) is shown in Figure 4.4.4.

Installation scheme of DH -1 (crossbeam) is shown in Figure 4.4.5.

Basic parameters of drawbar hitches shown in Tables 4.2, 4.3, 4.4, 4,5, 4.6 and in Figures 4.4.1, 4.4.2, 4.4.3, 4.4.4, 4.4.5 are given with standard rear tires (18.4R34 – both single and dual mounted to the tractor and with standard static radius, specified by the manufacturer.

4.4.2 Drawbar hitch DH-2V (short towing yoke)

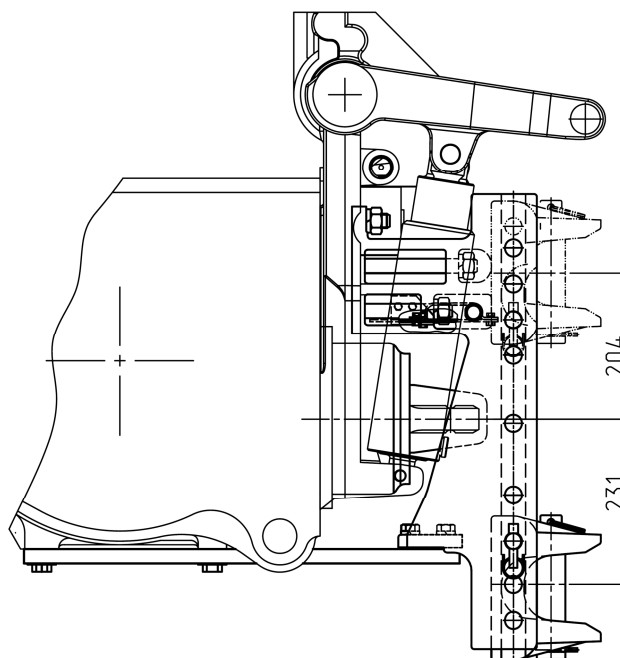

Figure 4.4.1 – Installation variants scheme of DH-2V (short towing yoke)

Table 4.2 – Basic parameters and coupling dimensions of DH-2V (short towing yoke)

Standard size (configuration)	DH-2V (short towing yoke)	
1 Variant	Yoke acc. to ISO	1 Variant
2 Mounting location	Rear lifting device	
3 Design features	Nonrotational, height adjustable	
4 Purpose	For connection and coupling of trailed, semi-trailed implements with traveling wheels including of tractor semi-trailer type	
5 DH yoke dimensions, mm:		
a) connecting pin diameter	40	
b) yoke gap height	85	
c) yoke gap width	70	
d) yoke position ¹ for the implements driven by rear PTO shaft	Lowermost position, as shown in figure 4.4.1	
e) distance between PTO shaft end extension and connection pin axis, mm	110	160
6 Trailing appliance for connection to DH:		
a) type	Rigid, with tractor drawbar clevis	
b) vertical load in hitch point, kN, not more than	20	
c) trailing appliance steering angle in horizontal plane, degrees, not less than	±60	
d) protective mean type	Safety chain (rope) ²⁾	
e) connection point of protective mean to the tractor	Lifting device bore	
¹⁾ Recommended. ²⁾ Implement accessories		

ATTENTION: IT IS FORBIDDEN TO PUT DH-2V YOKE TO A POSITION WHERE ITS BODY OVERHANGS THE DH SUPPORTING BRACKET END FOR MORE THAN 15 MM!

4.4.3 Drawbar hitch DH-3V (long towing yoke)

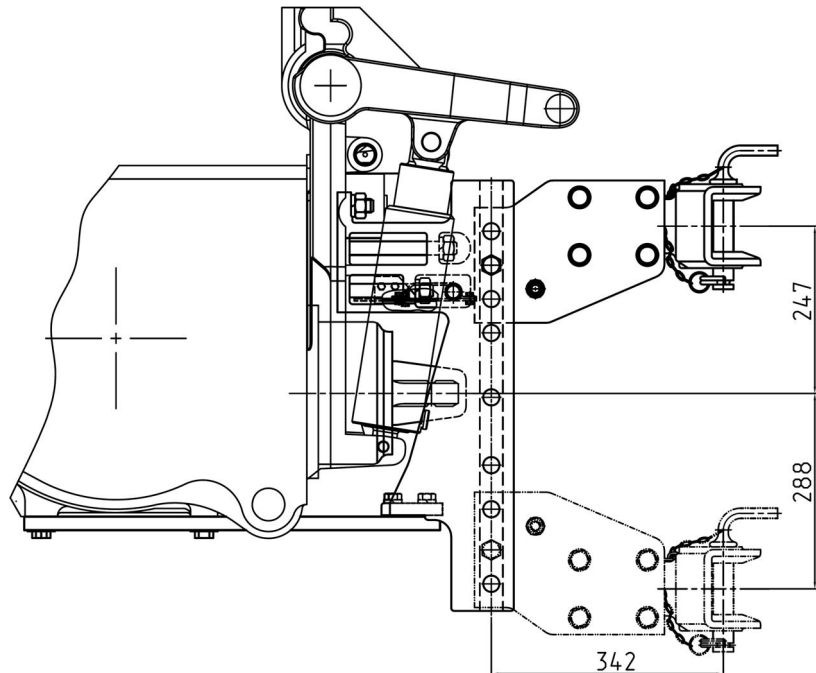

Figure 4.4.2 – Installation variants scheme of DH-3V (long towing yoke)

Table 4.3 – Basic parameters and coupling dimensions of DH-3V (long towing yoke)

Standard size (configuration)	DH-3V (long towing yoke)
1 Mounting location	Rear lifting device
2 Design features	Rotational, height adjustable
3 Purpose	For connection and coupling of trailed implements, including of tractor trailers equipped with drawbar clevises
4 DH yoke dimensions, mm: a) connecting pin diameter b) yoke position ¹ for the implements driven by rear PTO shaft c) distance between PTO shaft end extension and connection pin axis	30 Lowermost position as it is shown in Figure 4.4.2 400
5 Trailing appliance for connection to DH: a) type b) vertical load in hitch point, kN, not more than c) trailing appliance steering angle in horizontal plane, degrees, not less than d) protective mean type e) connection point of a protective mean to the tractor	Rigid, with tractor drawbar clevis 12 ±60 Safety chain (rope) ²⁾ Lifting device bores
¹⁾ Recommended. ²⁾ Implement accessories.	

ATTENTION: IT IS FORBIDDEN TO PUT DH-3V YOKE TO A POSITION WHERE ITS BODY OVERHANGS THE DH SUPPORTING BRACKET END FOR MORE THAN 15 MM!

4.4.4 Drawbar hitch DH-2R (python)

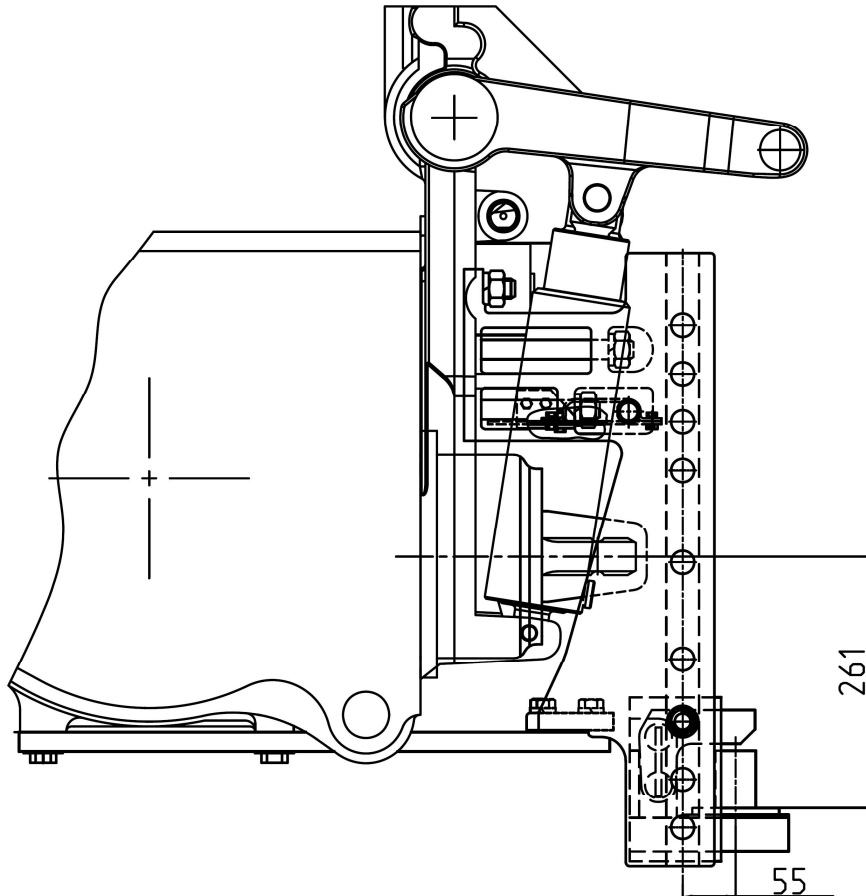

Figure 4.4.3 – Installation variants scheme of DH -2R (python)

Table 4.4 – Basic parameters and coupling dimensions of DH-2R (drawbar hitch “python”)

Standard size (configuration)	DH-2R (drawbar hitch “python”)
1 Mounting location	Rear lifting device
2 Design features	Cantilever fitted connection pin, vertically adjustable
3 Purpose	For coupling of semi-trailed implements, and implements of tractors semi-trailers types having also hitch clevis
4 Distance between PTO shaft end extension and connection pin axis, mm	108
5 Connecting pin diameter, mm	40
6 Vertical load on DH in hitch point, kN, not more than	20
7 Protective mean type	Securing chain (cable) ¹⁾
8 Connection point of a protective mean to the tractor	Holes in lifting device

¹⁾ Implement accessory.

ATTENTION: IT IS FORBIDDEN TO PUT THE DEVICE TO A LOWERMOST POSITION, WHERE IT OVERHANGS THE DH SUPPORTING BRACKET END!

4.4.5 Drawbar hitch DH-1M-01 (draw bar)

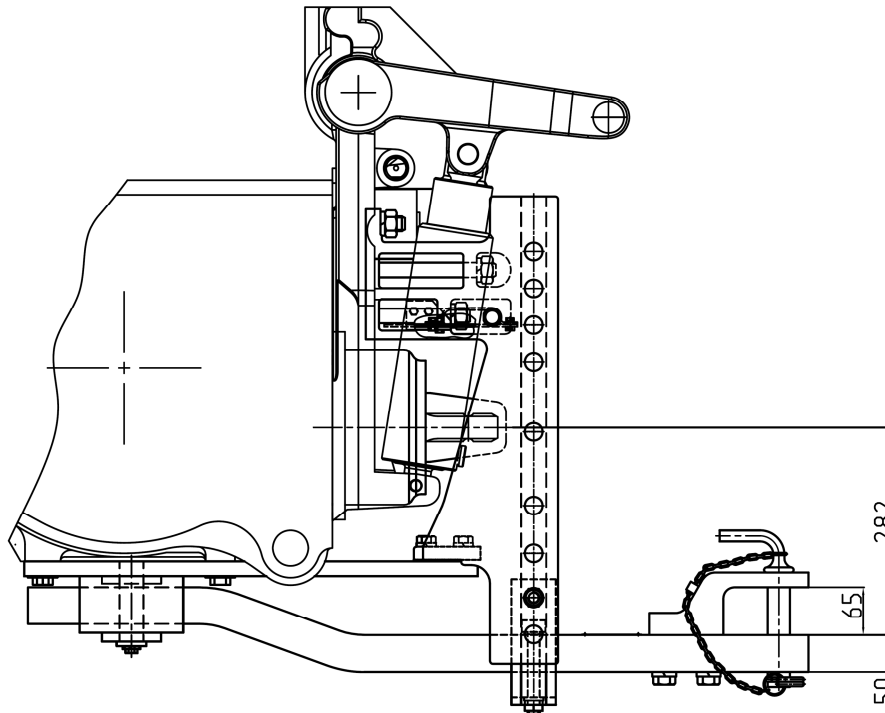

Figure 4.4.4 – Installation variants scheme of DH-1M-01 (draw bar)

Table 4.5 – Basic parameters and coupling dimensions of DH-1M-01 (draw bar)

Standard size (configuration)	DH-1M-01 (draw bar)	
1 Variant	First position	1 Variant
2 Mounting location	At the bottom of rear axis body and rear lifting device	
3 Purpose	For connection and coupling of trailed, semi-trailed implements with traveling wheels excluding tractor trailers and semi-trailers	
4 Design features	Draw bar with possibility to change its horizontal position against PTO shaft end butt	
5 Distance between PTO shaft end extension and connection pin axis, mm	400	500
6 Vertical load on DH in hitch point, kN, not more than	12	8
7 Trailing appliance steering angle in horizontal plane, degrees, not less than	±60	
8 Connecting pin diameter, mm	30	
9 Protective mean type	Safety chain (rope) ¹⁾	
10 Connection point of a protective mean to the tractor	Lifting device bore	

¹⁾ Implement accessory.

ATTENTION: MOUNTING OF COVER PLATE TO DRAW BAR BOTTOM (WITH OVERTURN) TO REDUCE HEIGHT OF YOKE POSITIONING AGAINST SUPPORTING SURFACE IS NOT ALLOWED!

4.4.6 Drawbar hitch DH -1 (crossbeam)

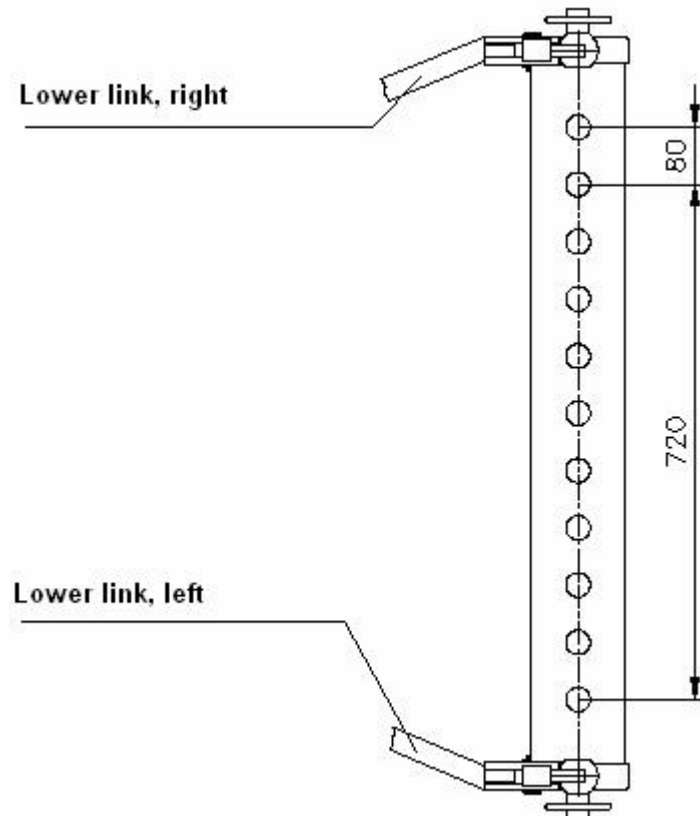

Figure 4.4.5 – Installation scheme of DH -1 (crossbeam)

Table 4.6 – Basic parameters and coupling dimensions of DH-1 (crossbeam)

Standard size (configuration)	DH-1 (crossbeam)
1 Mounting location	On a suspension axis of rear lift linkage
2 Design features	Draw crossbeam on suspension axis of rear lift linkage
3 Purpose	For connection and coupling of trailed, semi-trailed and semi-mounted implements, equipped with towing yokes
4 Distance between PTO shaft end extension and connection pin axis, mm	595
5 Diameter of crossbeam holes for connecting pin, mm	32,5
6 Vertical load on DH in hitch point, kN, not more than	3,5
7 Protective mean type	Safety chain (rope) ¹⁾
8 Connection point of a protective mean to the tractor	Lifting device bore
¹⁾ Implement accessory.	

On order your tractor can be equipped with a double crossbar (TSU-1ZH-01). Vertical load on the double crossbar in the coupling point shall not exceed 12 kN.

4.5 Usage patterns of tractor hydraulic system for driving of operated parts and other elements of unitized hydraulically operated machines and aggregates

Hydraulic control system for implements mounted on tractor "BELARUS-1025.5" provides means for oil extraction for operation of the implements coupled. Meanwhile the following variants are possible:

- oil extraction by unilateral and bidirectional hydraulic cylinders (hereinafter referred to as hydraulic cylinders);
- replenishment of oil volume in a tank caused by flooding of cylinder and fittings chambers shall be assured after trial of performance of the hydraulic system of the tractor with an implement;
- oil extraction for hydraulic motors drives (hereinafter referred to as hydromotors), in this case the implement applicability shall be obligatory agreed with tractor manufacturer's work.

While operating hydraulically operated machines with hydraulic motor its drain pipe must be connected to a special tractor output to ensure free oil drain into the tank by-passing distributor. In case of its absence, connect the drain pipe to oil tank through fill plug.

ATTENTION: FOR ENSURING OF THE REQUIRED ROTATIONAL SPEED OF THE HYDRO MOTOR OF THE IMPLEMENTS COUPLED CERTAIN OIL SUPPLY IS NECESSARY. HYDRAULIC FLUID FEEDING ON THE TRACTOR "BELARUS-1025.5" DEPENDS ON THE ENGINE RPM, THEREFORE IMPLEMENT HYDRAULIC DRIVE MUST BE EQUIPPED WITH ITS OWN FLOW ADJUSTING VALVE!

In case of use of outputs of tractor hydraulic system for maintenance of the implement coupled, it is necessary to ensure the required volume of oil in a tank. Extraction of oil by cylinders of the implement coupled should not exceed 8 liters.

Excessive oil extraction during coupling causes load increase on hydraulic system of a tractor. At long-term use of a hydraulic drive it is necessary to track a temperature range in a hydraulic system.

Level check in a tractor hydraulic tank and its refill shall be carried out with retracted cylinder rods (plungers) of the tractor as well as implement coupled. You must not fill in the oil when cylinder rods (plungers) are pulled out as it can result in the tank overflow and blow-out of elements of a hydraulic drive by the excessive oil being displaced from cylinders at the subsequent lowering (raising) of the working attachments.

Major characteristics of tractor "BELARUS-1025.5" HLL for working attachments drive of other components of the hydraulically operated implements and units coupled are shown in Table 4.7.

Table 4.7 – Characteristics of tractors "BELARUS-1025.5" hydraulic drive

Parameter description	Parameter Value (characteristic)	
	Side	Rear
1 Paired hydraulic outputs (free)	Two pairs	Two pairs ²⁾
2 Oil pipe for free draining into tank (free drain line)	-	One
3 Total oil consumption through hydraulic outputs, l/min	Up to 56 ¹⁾	

4 Rated minimum diameter of oil pipeline, mm: - oil pressure pipeline - oil drain pipeline - free-drain	16,0 25,0 12,0
5 Hydraulic system working pressure, MPa	16,0
6 Pressure relief cracking pressure, MPa	20 ₋₂
7 Allowable extraction of hydraulic fluid from a tank, l, not more than	8,0
8 Allowable hydrostatic power take-off (GSPTO) kW, not more than	12,0
9 Coupling thread of fast-coupling joint sleeves, mm: - oil pressure pipeline and oil drain pipeline - free-drain oil pipeline	M20×1,5 M20×1,5
<p>1) At rated engine speed</p> <p>2) Left output is duplicated with left side output if distributor valve is controlled by means of three hand levers; the right output is duplicated with the right side output if distributor valve is controlled by means of joystick and lever</p>	

ATTENTION: INSTALLATION OF ADDITIONAL COMPONENTS AND CHANGE OF HYDRAULIC LIFT LINKAGE PIPELINES ROUTE IS ALLOWED ONLY AFTER CONSULTATION WITH THE PLANT OR THE DEALER!

Note – Scheme of connection of hydraulic lift linkage outputs to an external consuming system is given in section 2 “Controls and instruments”.

4.6 Front ballast weight installation

When operating with heavy coupled implements and tools mount supplementary weights 1 (Figure 4.6.1) to retain normal steerability of the tractor under conditions of considerable unloading of the front axle. The ballast weights 1 are mounted on a special bracket 6, which is attached to the front bar 5 of the tractor and is fastened by a pin 4 and a nut 7.

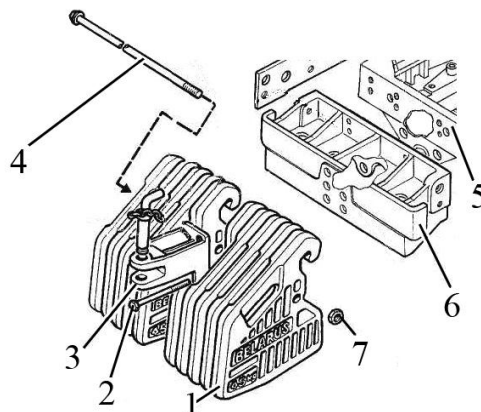

1 – supplementary ballast weights; 2 – bolt for fastening supplementary ballast weights and towing device; 3 – towing device; 4 – pin; 5 – front bar; 6 – bracket; 7 – nut.

Figure 4.6.1 – Front ballast weight installation

Installation of two types of supplementary ballast weights is possible:

- 450 kg ballast weights (10 pieces 45 kg each);
- 360 kg ballast weights (8 pieces 45 kg each).

The basic configuration includes mounting of 450 kg ballast weights.

4.7 Trailer brake actuator

4.7.1 General information

Your tractor can be equipped with a double-line pneumatic actuator for trailer brakes or a hydraulic actuator for trailer brakes. Brief data on the structure of the double-line pneumatic actuator for trailer brakes is given in subsection 4.7.2. Brief data on the structure of the hydraulic actuator for trailer brakes is given in subsection 4.7.3.

ATTENTION: ALL ADJUSTMENT OPERATIONS OF THE BRAKING SYSTEM AND THE ACTUATOR OF TRAILER BRAKES AS WELL AS FAULTS ELIMINATION SHALL BE CARRIED OUT WITH THE ENGINE KILLED AND THE TRACTOR STAYING IN A HORIZONTAL POSITION, WHICH SHALL BE SECURED BY STOP BLOCKS PUT BEHIND THE WHEELS AND PREVENTING THE TRACTOR FROM SELF-MOVEMENT!

4.7.2 Double-line pneumatic drive of trailer brakes

Tractors BELARUS-1025.5 in base-line configuration are equipped with double line pneumatic drive providing brake control of trailers and agricultural machines, equipped with two-line pneumatic brake drive. The pneumatic drive is used also for tires charging and other purposes where energy of compressed air is required. The configuration of two-line pneumatic drive is shown in figure 4.7.1.

In the pneumatic drive are installed the connecting heads 11, 12 (figure 4.7.1) of valve type. The valves of connecting heads prevent air outlet, if pneumatic drive is used without trailer (for example, tire charging) and at emergency trailer disconnection. At connection of the trailer brake lines with tractor lines the valves of connecting heads open, providing passage of the compressed air from tractor pneumatic drive to the trailer. It is necessary to connect pneumatic lines, if there is no pressure in tank 4 of the tractor.

ATTENTION: BEFORE CONNECT OR DISCONNECT TRACTOR AND TRAILER PNEUMATIC LINES, ENGAGE PARKING BRAKE! IT IS NECESSARY TO CONNECT TRACTOR AND TRAILER PNEUMATIC LINES WHEN THERE IS NO PRESSURE IN PNEUMATIC SYSTEM OF THE TRACTOR!

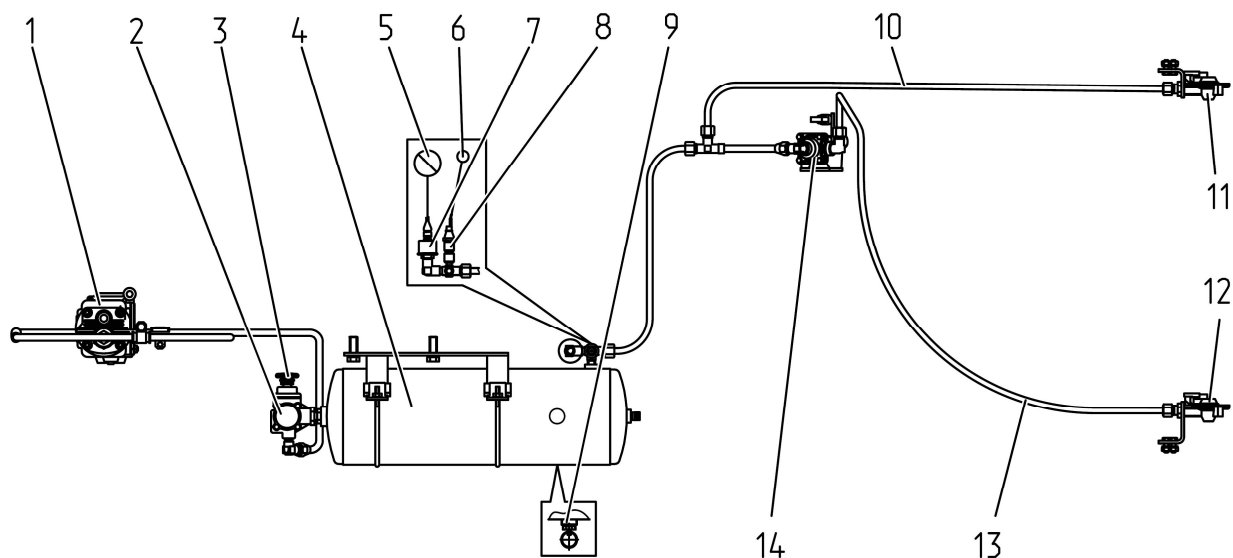

1 – compressor; 2 – pressure regulator; 3 – air bleed valve; 4 – tank; 5 – air pressure indicator; 6 – alarm lamp of emergency air pressure; 7 – air pressure sensor; 8 – emergency air pressure sensor; 9 – condensate drain valve; 10 – feed line; 11 – connecting head of feed line (with red cap); 12 – connecting head of control line (with yellow cap); 13 – control line; 14 – brake valve.

Figure 4.7.1 – Configuration of double-line pneumatic drive of trailer brakes

4.7.3 Hydraulic drive of trailer brakes

4.7.3.1 General information

Tractors "BELARUS-1025.5" can be optional equipped with hydraulic drive of trailer brakes.

The hydraulic drive of trailer brakes is interlocked with tractor working brakes control and insures actuation of wheel brakes of trailer or semi-trailer, equipped with the system of hydraulic drive of trailer brakes. The hydraulic connecting line is fed from the HLL pump that provides pressure between 10 ...15 MPa and is made as single-line brake system. The connection of hydraulic drive corresponds to the standard ISO/5676 of 1983.

The hydraulic drive of trailer brakes consists of brake valve 3 (figure 4.7.2) with mechanical control activated with a help of the rod 2 connected to the pedals of tractor working brakes and coupling 1 that connects brake drive system of trailer or semi-trailer with hydraulic drive of tractor brakes. The hydraulic drive of trailer brakes is subsequently fed from pump 6 of tractor hydraulic lift linkage with a help of high-pressure hoses 4 and 5.

The coupling 1 prevent oil run-out when hydraulic drive is used without the trailer. When brake line of the trailer is connected with brake line of the tractor the coupling insures oil passing to the trailer.

ATTENTION: TRACTOR EQUIPPED WITH HYDRAULIC DRIVE OF TRAILER BRAKES CAN NOT BE COUPLED WITH TRAILER WITHOUT HYDRAULIC DRIVE OF THE BRAKES!

ATTENTION: CONNECT AND DISCONNECT BRAKE HYDRAULIC LINE OF THE TRACTOR AND TRAILER ONLY IF THE ENGINE IS NOT RUNNING AND PARKING BRAKE IS ACTUATED.

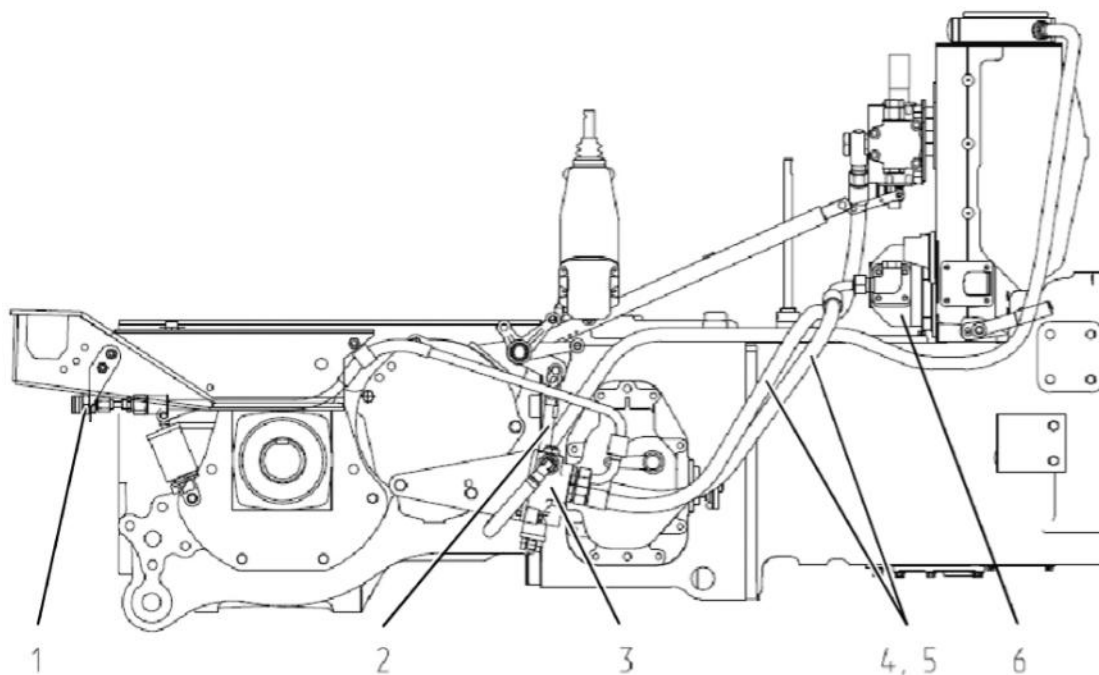

1 – coupling; 2 – rod; 3 – brake valve; 4, 5 – high pressure hose; 6 – pump.

Figure 4.7.2 – Hydraulic drive of trailer brakes

4.7.3.2 Adjustment of hydraulic actuator of trailer brakes

The adjustment of the hydraulic actuator of trailer brakes consists in adjustment of a rod 2 (Figure 4.7.3) of the brake valve 1. The dimension "A" (0.5 to 1 mm, between the pin and the upper edge of the groove in the lever) shall be checked with the main brake pedals released and the parking brake fully disengaged changing it by turning the end 4 of the rod 2. The dimension Б (35 ± 1.25 mm) between the lower edge of the end 4 and the upper nut 3 (Figure 4.7.3) shall be provided by turning the nuts 3. After the adjustment is completed both nuts 3 shall be locked.

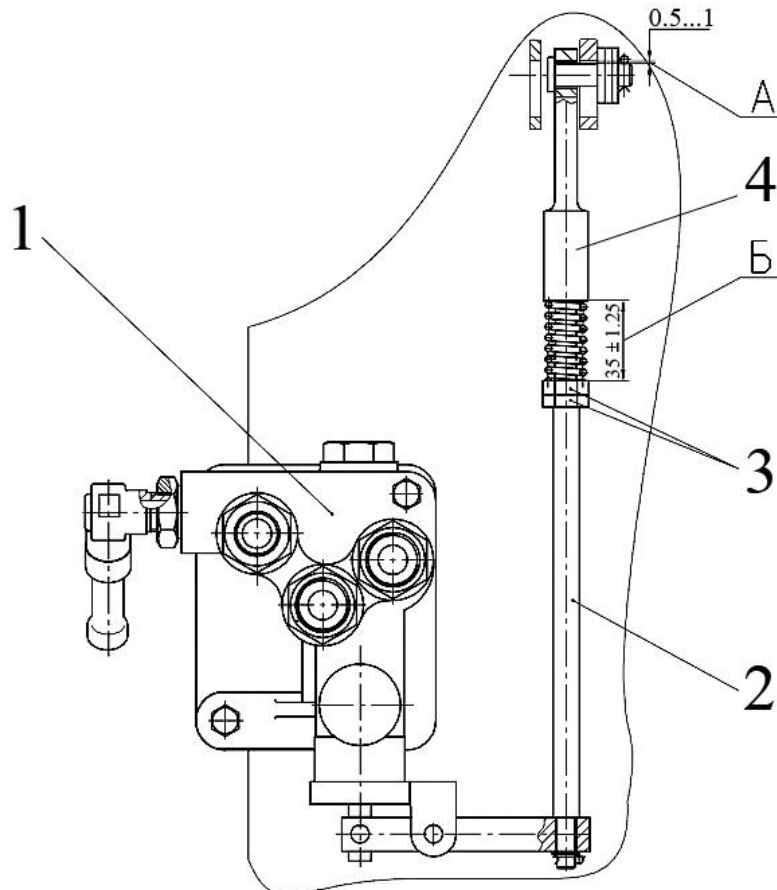

1 – brake valve; 2 – rod; 3 – nut; 4 rod end.

Figure 4.7.3 – Adjustment of the rod of the brake valve of the trailer brake hydraulic actuator

ATTENTION: THE ADJUSTMENT OF THE BRAKE VALVE ACTUATOR SHALL BE CARRIED OUT WITH THE SERVICE BRAKE PEDALS RELEASED AND THE PARKING BRAKE FULLY DISENGAGED, WHICH SHALL BE PREVIOUSLY ADJUSTED!

4.8 Determination of PTO shaft and cardan shaft applicability

To avoid failures of PTO shaft and PRS in several implements with active working attachments (tilling rotary implements, combine harvester, mowers, cattle-feeders, pickup balers and etc.) mechanical safety clutches are used.

Functional purpose of the safety clutch is automated gear deactivation or limitation of the torque value transmitted from the PTO shaft to PRS under overloads caused by large starting moment, overload of (locks) the working attachments and loads fluctuations on the PRS drive.

ATTENTION: THE IMPLEMENT COUPLED SAFETY CLUTCH RESPONSE TIME SHALL EXCEED THE NOMINAL OPERATING TORQUE ACTING FOR A LONG TIME IN THE IMPLEMENT DRIVE, BUT BE ALWAYS EQUAL TO OR LESS THAN THE MAXIMUM PERMISSIBLE PTO SHAFT TORQUE! IF THE IMPLEMENT SAFETY CLUTCH RESPONSE TIME EXCEEDS THE PERMISSIBLE PTO SHAFT TORQUE SUCH IMPLEMENT MUST NOT BE COUPLED WITH THE TRACTOR.

Among safety clutches there are cam clutch, frictional clutch, disk clutch, they can be subdivided to two basic types – with destructible and indestructible working components. Clutches with a destructible component are used as unlikely overload control device.

ATTENTION: IT IS NOT RECOMMENDED TO USE CARDAN SHAFTS WITH SAFETY CLUTCHES WITH A DESTRUCTIBLE COMPONENT FOR IMPLEMENTS COUPLING WITH TRACTORS “BELARUS-1025.5”!

In several implements freewheeling clutches are used. The freewheeling clutches (sprag clutches) are automatically closed if the rotating direction is straight, and are unclosed if the rotating direction is opposite. The freewheeling clutches ensure operation of the implements with the increased inertia moment of the implement rotating masses to prevent it from the drive failure when the PTO shaft is switched off.

There are also combination safety clutches. A combination safety clutch is the safety clutch which is structurally combined with a clutch of other type, for example with a freewheeling clutch.

ATTENTION: MANUFACTURER OF THE IMPLEMENT CARDAN-DRIVEN FROM THE TRACTOR PTO SHAFT SHALL INFORM YOU IN ADVANCE ABOUT THE NECESSITY OF APPLICATION OF A SAFETY CLUTCH, CLUTCH DESIGN FEATURES AND CONSEQUENCES OF THE IMPLEMENTS APPLICATIONS WITHOUT THE SAFETY CLUTCH!

When you need to decide on the purchase or operation of the cardan shaft follow the implements and cardan shaft manufacturers' guidelines first of all. It is recommended to apply with the tractor the implements with active working attachments where the length between the articulations of the fully off-set cardan shaft does not exceed 1 m.

4.9 Features of application of PTO shafts and cardan shafts

WARNING: BE CAREFUL WHEN PTO SHAFT IS ACTIVATED AND THE CARDAN SHAFT OF THE IMPLEMENT COUPLED IS ROTATING. IN CASE THERE ARE PEOPLE IN AREA OF OPERATION OF PTO SHAFT THEY OR THEIR CLOTH CAN BE CLAMPED BETWEEN THE IMPLEMENT ROTATING PARTS AND OTHER MOVING MACHINERY, THAT CAN RESULT IN PERMANENT INJURY INCLUDING WITH FATAL OUTCOME, THEREFORE BEFORE STARTING THE PTO SHAFT ENSURE THERE IS NO PEOPLE IN DANGEROUS AREA BETWEEN THE TRACTOR AND THE IMPLEMENT. WORKS ASSOCIATED WITH MAINTENANCE SERVICES (ADJUSTMENT, GREASING AND ETC.), MOUNTING AND DISMOUNTING OF THE CARDAN SHAFT SHALL BE CARRIED OUT WHEN THE TRACTOR PTO SHAFT AND ENGINE ARE DISABLED. BEFORE STARTING THE CARDAN SHAFT MOUNTING, STOP THE ENGINE, GET THE IGNITION KEY OUT OF STARTER SWITCH AND THE DEVICES, AND SET THE PARKING BRAKE!

ATTENTION: TRACTOR MANUFACTURER SHALL NOT BE LIABLE FOR THE IMPLEMENTS COUPLED CARDAN SHAFTS FAILURES. CARDAN SHAFTS SPECIFICATIONS AND DESIGN ARE IN SPHERE OF RESPONSIBILITY OF THE IMPLEMENTS

AND CARDAN SHAFT MANUFACTURERS!

ATTENTION: CARDAN SHAFT OF IMPLEMENT COUPLED MUST ENSURE TRANSFER OF RATED-LOAD TORQUE WHEN ROTATION FREQUENCY IS NOT LESS THAN 540 RPM OR 1000 RPM, DEPENDING ON THE SET MODE!

ATTENTION: DO NOT USE THE CARDAN SHAFTS WITHOUT THE APPROPRIATE PROTECTIVE DEVICES AND IF THEY ARE SELF-MANUFACTURED OR DAMAGED!

ATTENTION: BE CAREFUL WHEN COUPLING OF THE IMPLEMENTS WITH THE CARDAN DRIVE: DEFLECTION ANGLES OF THE CARDAN SHAFT ARE LIMITED BY THE TRACTOR STRUCTURAL COMPONENTS, FOR EXAMPLE, BY LIFTING DEVICE GUIDING RODS OR TRACTOR WHEELS. DUE TO MUTUAL TOUCH-DOWN OF THE CARDAN SHAFT AND OTHER STRUCTURAL COMPONENTS, SOME BREAKAGE OF THE IMPLEMENT TRAILING APPLIANCE CAN OCCURE OR, FOR EXAMPLE, TRACTOR TIRES OR THE CARDAN SHAFT DAMAGE!

ATTENTION: WHEN THE IMPLEMENT IS OPERATED WITH THE CARDAN SHAFT THERE IS A HAZARD OF PROCESS MATERIAL OR THE IMPLEMENT COMPONENTS RELEASE, THEREFORE IT IS NECESSARY TO OBSERVE SAFE DISTANCE!

When the implement cardan shaft is coupled to the PTO shaft end extension the following rules and requirements shall be observed:

1. Check the engaged PTO shaft speed mode for compliance according to tractor PTO shaft end type and implement PRS installed, check the engaged rear PTO drive (continuous/ground-speed) for compliance;
2. Before engagement detach the cardan shaft into two parts.
3. Inspect the cardan shaft, PTO shaft and PRS for absence of mechanical damage and for completeness of the set. Clear the PTO shaft end extensions of dirt when needed, and lubricate it according to the lubrication chart, specified in the implement operation manual.
4. The cardan shaft part having the icon of "Tractor" on it, shall be coupled to the PTO shaft end extension, and the second part – to the implement PRS accordingly. Do not forget to fasten contactor splined bushings on the PTO and PRS shaft ends properly: fastening method shall be specified by the cardan shaft manufacturer.
5. The implement cardan shaft end yoke from the side of PTO shaft and PRS shall be in the same plane as indicated in Figure 4.9.1.

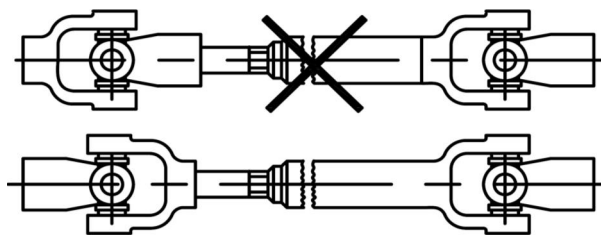

Figure 4.9.1 – Cardan shaft mounting scheme

6. Safety clutch, as indicated in Figure 4.9.2, shall be installed only from the side of PRS of the drive of the implement coupled, other method of mounting will not ensure the excess of timely protection of the tractor PTO shaft from the maximum permissible torque. After lengthy downtime check the implement safety clutch technical condition.

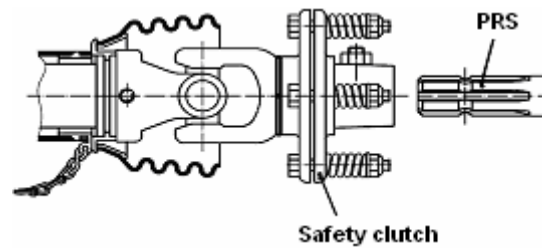

Figure 4.9.2 – Safety clutch mounting scheme

7. Mounting of the cardan shaft with guard housing together with PTO shaft and PRS protective devices, with retaining chains both from the side of the PTO shaft and of the PRS, as indicated in Figure 4.9.3, ensures cardan joint safety.

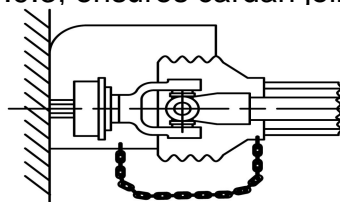

Figure 4.9.3 – Safety cardan shaft mounting scheme

8. When the cardan shaft is used for the first time it is necessary to check the cardan shaft length, and to adjust it to the operating conditions with tractors “BELARUS-1025.5” when needed. For more detailed guidelines on cardan shafts see the technical documentation enclosed. Contact the cardan shaft manufacturer when needed.

9. The length of the cardan shaft maximum driven apart (which is permitted for operation) shall be of such type when the one part of the cardan shaft enters another for not less than $L_2=150$ mm. If the value is below $L_2=150$ mm (Figure 4.9.4, view A) the cardan shaft must not be operated. Sufficiency of overlapping L_2 can be checked by rotation or lifting of the implement coupled.

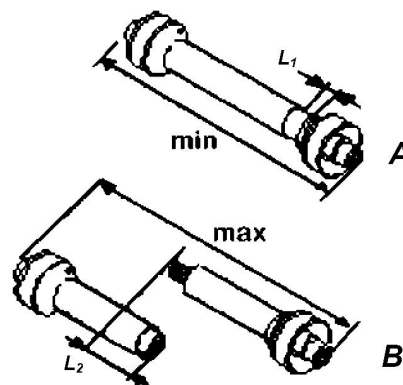

Figure 4.9.4 – Choice of the cardan shaft length

10. If the tractor and the implement coupled are positioned linearly when the cardan shaft is pushed in full, check if there is a sufficient clearance L_1 (Figure 4.9.4, view C) between tube face and universal joint yoke end butt. Minimum permissible clearance L_1 shall make not less than 50 mm

11. After the cardan shaft coupling regularize all the protective devices, meanwhile fix the guard shaft housing from rotation with the chains as indicated in Figure 4.9.3.

12. Limit the RLL lifting to the uppermost position along with the implement lifting when needed. It is essential for slope angle decrease, for exclusion of possibility of contact and damage of the cardan shaft, and for providing of safety clearance between the tractor and the implement.

13. Maximum permissible slope angles and steering angle (Figure 4.9.5) of the cardan shaft hinged joints are shown in Table 4.8.

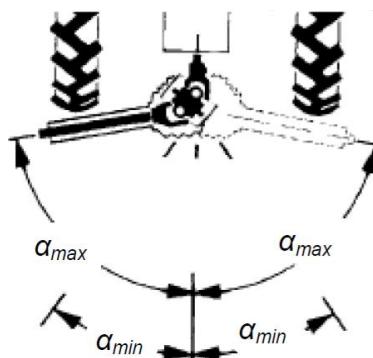

Figure 4.9.5 – Maximum permissible slope angles and steering angle of the cardan shaft hinged joints

Table 4.8

Tractor power take-off shaft position	Maximum permissible slope angles (steering angle) $\alpha_{max}^{1)}$, in degrees	
	Cardan shaft hinged joints type	
	Universal	Equivalent angular rates
“On” position:		
- under load	20	25
- no-load ²⁾	50	50
“Off” position ³⁾	50	50

¹⁾ Other variations are possible (see the cardan shafts and the implements manufacturers' documentation).
²⁾ In the short run, for the PTO shaft operated with no load.
³⁾ For the implements transport position when the PTO shaft is disabled.

14. In case of mounted and semi-mounted implements operation with the cardan drive, block the lower links of the lift linkage.

15. After the cardan shaft dismounting it is necessary to put guard hoods on the PTO shaft end extensions and PRS!

16. After the PTO shaft is disabled consider the hazard of the cardan shaft and individual mechanisms of the implement coasting. Therefore the dangerous area between the tractor and the implement can be entered only after the PTO shaft is completely despinned!

17. Check for operation of the implement with the cardan shaft mounted to the PTO shaft and PRS at the minimum and maximum rpm of the tractor engine shaft.

18. At transporting of the tractor with the trailed, semi-trailed and semi-mounted implements for considerable distances, including from one field to another, disconnect the cardan shaft from the tractor and from the implement

19. Maintenance, cleaning and repair services of the implement with the cardan drive coupled to the tractor shall be carried out only when the PTO shaft and the tractor engine are disabled.

The PTO shaft shall be disabled in the following cases:

- after the tractor has been stopped, but only after the implement coupled has come full duty cycle;
- on turns, when the implement is lifted to the transport position;
- when moving on the sharp climb and sharp descent.

Do not engage PTO shaft in the following cases:

- when the tractor engine is disengaged;
- the implement coupled to the tractor is in transport position;
- when the working attachments are sunken into the soil;
- if a process material overlays the implement working attachments or if the working attachments are clogged or wedged;
- if the slope angle (refraction angle) in any plane of cardan shaft hinged joint is a considerable.

During operation of the rotation tilling machine with the active working attachments comply with the following guidelines:

- do not engage the PTO shaft when the implement is grounded. The PTO shaft shall be engaged only when the ready-to operate implement is lowered down with the working attachments staying off the ground with clearance making not less than 20...35 mm;
- lowering down of the implement with rotating working attachments shall be carried out in a smooth manner when the tractor is moving forward;
- prevent the tractor from moving in the direction not corresponding the implement working travel during operation, when the working attachments are sunken with engaged and disengaged PTO shaft;
- during operation on strong soils at first carry out processing of cross ranges for moving in the disclosure, and than the lengthwise tillage can be started;
- it is recommended to work at minimum processing depth, required for the specific crop. It is necessary for load on the tractor PTO shaft reduction and reduction of fuel consumption during the tractor operation. Particularly it is important to consider it at the tractor operation with multiple-purpose tilt-plant units.

4.10 Ways of changing of drawbar features and passing ability of the tractors

There are the following means of changing the gripping properties of "BELARUS-1025.5" tractor:

- increase of tractor adhesion weight;
- increase of wheel tire-soil adhesion.

To increase the adhesion weight of the tractor the following could be done:

- use of quick-detachable hitch ballast weight;
- filling of tires with water (solution);

To increase wheel tire-soil adhesion the following could be done:

- selection of optimal internal pressure in tires, depending on the operating conditions and load on the tractor axles;
- applying the rear axle differential lock;
- wheel doubling.

Note – Pneumatic pressure rate in the front and rear tires of the tractors "BELARUS - 1025.5" under actual load is shown in subsection "Selection of optimal internal pressure in tires, depending on the operating conditions and load on the tractor axles".

To obtain information on the rules of rear wheel doubling and filling of wheel tires with water (solution), as well as on operating limitations for tractors equipped with doubled wheels and tires with water (solution) contact your dealer.

4.11 Features of the tractor application in special conditions

4.11.1 Tractor operation in areas with rugged topography.

Possibility of the tractor application for haulage allocation for reserve.

Operator working in the fields and roads with a slope coming downwards or upwards, shall be very careful.

Technical characteristics of the general-purpose implement coupled in the structure of MTU ensure its safe and proper operation on working field spaces with a slope not exceeding 9 degrees.

ATTENTION: TRACTORS "BELARUS-1025.5" ARE INAPPROPRIATE FOR OPERATION WITH THE GENERAL-PURPOSE IMPLEMENTS AT UPLAND ENVIRONMENT INCLUDING ON SHARP INCLINES. THEREFORE TRACTORS ARE NOT COMPLETED WITH SPECIAL-PURPOSE DEVICES, FOR EXAMPLE INCLINATION OF THE FRONT PART SIGNALING DEVICE!

ATTENTION: APPLICATION OF TRACTORS "BELARUS-1025.5" FOR GRASS STACKING (SILAGE OR HAYLAGE) IN TRENCHES AND PITS IS NOT ALLOWED!

4.11.2 Application of substances for the purpose of chemical treatment

Cabin corresponds to category 2 under EN 15695-1:2009. The cabin of this category protects from dust and vapor ingress, the tractor shall not be used in conditions requiring protection from aerosol and vapor ingress.

The cabin is equipped with ventilation, heating and conditioning system according to GOST 12.2.120. In ventilation system there are two paper filters with performance capabilities according to GOST ISO 14269-5. Cabin design ensures its proofness under GOST ISO 14269.

ATTENTION: CABIN OF THE TRACTOR "BELARUS-1025.5" CAN NOT PROTECT FROM POSSIBLE DAMAGING EFFECT OF SUBSTANCES USED FOR CHEMICAL TREATMENT OF AGRICULTURAL PLANTS AND SOILS INCLUSIVE OF SPRAY TREATMENT. THEREFORE, WHEN TREATING CHEMICAL SUBSTANCES, THE OPERATOR SHALL WEAR INDIVIDUAL PROTECTIVE EQUIPMENT IN ACCORDANCE WITH OPERATING CONDITIONS!

IT IS FORBIDDEN TO PLACE SUBSTANCES USED FOR CHEMICAL TREATMENT OF AGRICULTURAL PLANTS AND SOILS IN THE CABIN.

THE OPERATOR MUST NOT ENTER THE CABIN WEARING CLOTHES OR SHOES CONTAMINATED WITH SUBSTANCES USED FOR CHEMICAL TREATMENT OF AGRICULTURAL PLANTS AND SOILS.

For safe and proper application of the specified substances it is necessary to comply with instructions written on the labels and documents accompanying the substances.

All individual protective equipment and specialized clothing (knockabout suit and foot gear, etc), corresponding to the operating conditions and current safety requirements are required.

If the use of a breathing mask inhaler is required for chemical treatment by the application data sheet of the substance, it shall be used inside the tractor cabin.

4.11.3 Operation in a forest

IT IS FORBIDDEN TO USE TRACTOR "BELARUS-1025.5" FOR PERFORMANCE OF ANY WORK IN A FOREST, INCLUDING FOR CLAMSHELL LOADER COUPLING, TRAILING EQUIPMENT, SPECIAL-PURPOSE FORESTRY MACHINERY DESIGNED FOR GATHERING, LOADING, AND TRANSPORT OF TREES, AND THEIR UNLOADING, SORTING AND WAREHOUSING.

ATTENTION: ACCORDING TO THE PURPOSE THE TRACTOR "BELARUS-1025.5" IS DESIGNED FOR, SPECIAL OPERATOR POSITION PROTECTION DEVICE (OPS) IS NOT PROVIDED IN ITS DESIGN, INCLUSIVE OF SPECIAL ATTACHING POINT FOR THE DEVICE. THEREFORE THE TRACTOR SHALL NOT BE OPERATED IN CONDITIONS WHEN THERE IS A HAZARD OF TREES, ITS BRANCHES, AND SINGLE PARTS OF THE EQUIPMENT COUPLED PENETRATION INTO THE OPERATORS CABIN!

4.12 Finding of total weight, loads on the front and rear axles, tires holding capacity and required minimum ballast

Amount of load on the tractor axles in structure of MTU may be found by means of proximate weighting on truck scales of the corresponding carrying capacity.

Tractor weighting allows possibility to consider weight distribution of MTU masses along the tractor axles completed by you in different operating conditions: "main operation" and "transport". During load sensing on the tractor axles, the technological load weight, for example weight of seeds, distributed by a seeder, must be considered.

ATTENTION: TO REDUCE OVERLOAD OF THE REAR WHEELS AND FDA DURING COMPOUND UNITS COUPLING TOGETHER WITH USE OF RLL AND FLL, IT IS NECESSARY TO LIFT RLL WITH THE IMPLEMENT FIRST, AND FLL WITH THE IMPLEMENT NEXT. GROUNDING SHALL BE CARRIED OUT IN REVERSE ORDER.

For finding of a load on the tractor axis by means of weighting on truck scales, it is necessary to place the measured axis wheels of the tractor on a weighing platform, and other axis wheels shall be kept out of the area of weighting on a level with the platform.

The following formula is used for load sensing

$$T = m \cdot g, \text{ where}$$

- T is load, N;
- M is mass, kg, and
- g=9.8 is gravity acceleration, m/s²

Calculation of load on the front tractor axis

$$T_f = m_1 \cdot g, \text{ where}$$

- T_f is load on the front tractor axis, N;
- m₁ is amount of the tractor operating weight with ballast (unit installed), distributed on the tractor front axis, kg;
- g=9.8 is gravity acceleration, m/s².

Calculation of load on the rear tractor axis

$$T_z = m_2 \cdot g, \text{ where}$$

- T_z is load on the rear tractor axis, N;
- m₂ is amount of the tractor operating weight with unit installed (ballast), distributed on the tractor rear axis, kg.
- g=9.8 is gravity acceleration, m/s².

Calculation of load acting on one front or one rear tractor wheel for selection of pressure in tires:

a) during operation of tires on single wheels

$$G_f = \frac{T_f}{2}; \quad G_z = \frac{T_z}{2}, \text{ where } G_f \text{ and } G_z \text{ are loads, acting on one front or one rear tractor tire accordingly.}$$

b) during operation of tires on doubled wheels:

(considering a permissible load on a tire during operation of tires on doubled wheels):

$$1.7 G_f \text{ doubl.} = G_f$$

$$1.7 G_z \text{ doubl.} = G_z$$

$$G_f \text{ doubl.} = \frac{G_f}{1,7}$$

$$G_z \text{ doubl.} = \frac{G_z}{1,7}$$

where G_f doubl. and G_z doubl. are calculated loads for pressurization of tires during operation of tires on doubled wheels.

Further according to the calculated loads from Table 3.1 of loading instructions, tire pressure shall be determined (subsection 3.2.8 "Selection of tires internal pressure in depending on operating conditions and load on the tractor axles").

Tractor controllability criterion calculation:

$$k_f = \frac{T_f}{M_{\text{op}}}$$

If is load on the tractor front axis, N;

k_f is tractor controllability criterion;

M is tractor operating weight (during calculation ballasts weights in the tractor operating weight M are not taken into account), kg;

ATTENTION: COUPLING OF THE IMPLEMENTS TO THE TRACTOR SHALL NOT RESULT IN EXCESS OF PERMISSIBLE AXIS LOADING AND LOADS ON THE TRACTOR TIRES!

ATTENTION: MINIMUM WEIGHT OF THE IMPLEMENTS COUPLED AND BALLAST WEIGHTS USED SHALL ALWAYS MAKE NOT LESS THAN VALUES AT WHICH LOAD ON THE FRONT TRACTOR WHEELS IN STRUCTURE OF MTU SHOULD ALWAYS MAKE NOT LESS THAN 20% OF THE TRACTOR OPERATING WEIGHT, AND THE CONTROLLABILITY CRITERION SHOULD MAKE NOT LESS THAN 0.2!

4.13 Possibility of front loader installation

4.13.1 General information

When choosing, buying and mounting of mounted front loaders (hereinafter referred to as loaders) pay attention to conditions specified in the present tractor operation manual and in Table 4.9.

Table 4.9 – Rules of tractor use with loader

Name of indicator (characteristics)	Indicator (characteristics) value
Standard size of tractor wheel tires to which installation of loader is possible	360/70R24 – front, 18,4R34 – rear (of basic configuration or imported tires of the same type)
Tractor wheel tire pressure	Inner pressure in wheel tires shall be settled as for the speed of 30 km/h
Tractor wheel track, m, not less :	
- for front wheels	1800
- for front wheels	2100
Tractor axle weight limit (with regard to tractor and loader weights), kN, not more than:	
- for front axle;	38,0
- for rear axle	53,0
Tractor weight with mounted loader, kg, not more than	8000
Push force in cutting mode, kN, not more than	18,0
overloading protection while in cutting mode	Automated protection in loader design
Speed of tractor movement with loader installed, km/h, not more than:	
- operation speed with load	6
- operation speed without load	12
- traveling speed	20
Tractor ballasting with loader installed (when necessary)	1. Ballast weight – on rear lift linkage. 2. Water solution in rear tires
Places of loaders fastening to a tractor:	
- loader mounting frame	Front beam, frame rail, clutch case
- loader push rods	Semi-axle tubes, GB casings and rear axle
Shift-time control (testing parameters, in addition to STMS operations, listed in tractor and loader operation manual)	1. Tightness of fasteners of loader mounting frame and tractor wheels. 2. Tractor tire pressure
Connection of loader hydraulic system	Tractor hydraulic outputs
Recommended adjustment pressure of safety valve (when the automatic hydraulic distribution valve in a loader set is available) of the loader hydraulic system, MPa, not more than	17,0

ATTENTION: FORK LOAD DEPENDS ON OVERHANG AND DESIGN OF LOADER WORKING ATTACHMENTS, AND SPECIFICATIONS OF LIFTED LOAD!

IT IS FORBIDDEN TO USE WITH LOADER A TRACTOR HAVING NO CAB OR CANOPY TENT, NO NOT-WILLED MOVEMENT LIMITING SYSTEM (SEAT BELT), AND ALSO IN CONFIGURATION WITH FRONT AND REAR TIRES OF IRREGULAR CONFIGURATION.

For installation of the complete set of the loading equipment bores on a front beam, frame rail and a tractor clutch coupling case are used. For the purpose of unloading of a semi-frame and a tractor clutch coupling case use adjustable bars or other constructive elements connected to rear semi-axes tubes of rear axle transferring a part of push force to tractor rear axle. For rigidity maintenance it is desirable, that the right and left parts of loader mounting frame have been rigidly connected among themselves.

Loader installation scheme is shown in Figure 4.13.1.

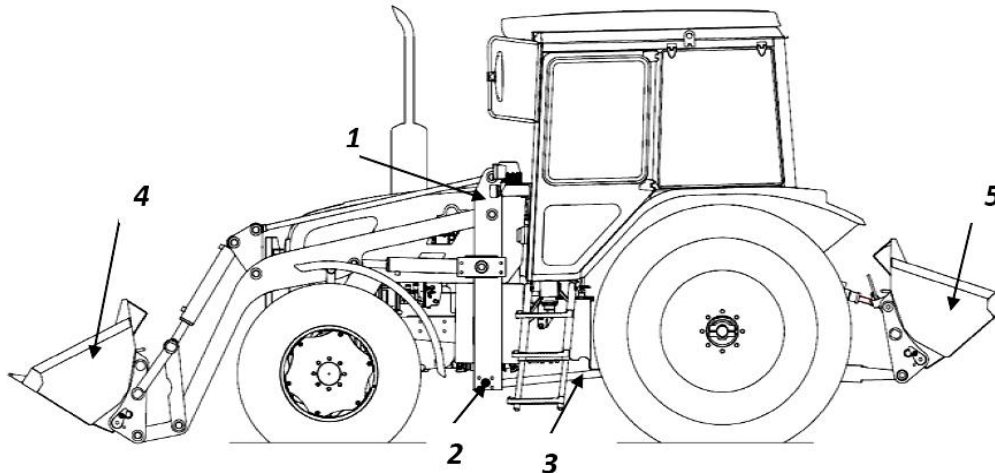

1 –loading equipment kit for tractor; 2 – crossed linkage of loader frame; 3 – tapped rod; 4 – loader bucket; 5 – rear ballast weight.

Figure 4.13.1 – Loader installation scheme

To ensure sufficient drawbar power generated by tractor rear wheels, it is necessary to create adequate load on rear axle equal or exceeding 60 % of tractor operational weight with regard to installed loader weight.

Right proportion of loads on axles can be achieved by rear axle ballasting by means of loads, solution, filled in wheel tires, rear counterweight (hook-on bucket with ballast load), attached to rear lift linkage.

ATTENTION: IN LOADER OPERATION MANUAL DESIGNED FOR CONSUMER, LOADER MOUNTING ORDER SHALL BE SET FORTH WITH PICTURES INCLUSIVE OF DATA ON SHIFTING AND DISMOUNTING OF TRACTOR COMPONENTS.

In a loader design safety and interlocking devices (fast coupling clutches, slowing-down valves, overload limiter and another), should be provided excluding conflicting motions of gears, overloads and breakages in operation on excess of admissible pressure values in hydraulic system, nominal load capacity or drawbar power.

In mode of ground cutting it is necessary to provide protection of tractor and loader chassis and from overload. Loader working attachment overturning (bucket and etc.), due to special valve actuation integrated in loader system.

In order to avoid breakages for the purpose of loader lowering speed limitation, the loader should be equipped with slowing-down valves in lifting cavity of loader hydraulic cylinders.

Loader design is to provide possibility of fixing working attachments in transport position.

To exclude contact and/or tractor and loader damages the minimum distances between fixed members of tractor and loader components attached to it should be not less than 0.1 m, and in case of moving member – not less than 0.15 m.

On a loader should bear marks "Maximum speed limitation", and also necessary warning labels, for example: to "Fix". On loader operating equipment limit values of load-carrying capacity should be specified on the fore.

ATTENTION: INSTALLATION ON THE TRACTOR "BELARUS-1025.5" OF MOUNTED FRONT LOADERS OF VARIOUS MANUFACTURERS IS ALLOWED IN CASE IT IS PROVIDED FOR IN LOADERS TECHNICAL DOCUMENTATION!

ATTENTION: FRONT LOADERS WHICH ARE NOT DESIGNED FOR USE TOGETHER WITH TRACTOR "BELARUS -1025.5" THEREFORE THEY MUST NOT BE INSTALLED ON THE TRACTOR!

Depending on INSTALLED replaceable operating equipment two modes of loader operation – "Loader" and "Bulldozer" are possible.

ATTENTION: PROVIDING CONSUMER WITH ALL KINDS OF NECESSARY TECHNICAL DOCUMENTATION, INCLUDING CONFIRMATION OF POSSIBILITY OF COUPLING OF LOADER WITH TRACTOR "BELARUS -1025.5", COME WITHIN DUTIES OF THE MANUFACTURER OF THE LOADER!

4.13.2 Safety measures at tractor "BELARUS-1025.5" operation with loader installed

During loader operation it is necessary to check on shift-time basis tightening of fasteners of mounting frame of loader and wheeled tractor, and pressure in tires.

During loader operation observe safety requirements listed in subsection 3.3 "Safety measures to be taken when operating the tractor".

Additionally during loader operation it is forbidden to:

- carry load with weights exceeding those specified in loader OM;
- fill loader bucket amain, to work on soft soils;
- place bucket outside slope crest when throwing off soil aslope (in order to avoid tractor slipping);
- transport load in bucket at maximum boom length;
- work with cracks on rims and with tires damaged up to the cord or perforation damage;
- to leave a tractor with lifted load;
- to make all types of turns and reverse movements with working attachments buried;
- work with faulty light, signaling system, steering and brakes;
- carry out operations at night with faulty electrical equipment and insufficient light of a working area,
- lift people by means of loader;
- lift and move loads if there are people in dangerous zone (danger line is near the moving members and working attachments of loader is within 5 m unless other exclusive requirements are specified in specification or manufacturer's instruction);
- carry out tractor maintenance with loader arm raised;
- make loading and unloading operations under electric power lines;
- carry loader bucket over a car cabin.

ATTENTION: TO IMPROVE LONGITUDINAL STABILITY AND RELIEF OF LOAD ON FRONT AXLE, TRACTOR COUPLED WITH LOADER CAN BE EQUIPPED WITH REAR LINKAGE-MOUNTED BALANCE WEIGHTS!

OPERATION OF LOADER ON THE SLOPE MORE THAN 8 GRADES IS FORBIDDEN!

Tractor service brake control pedal should be blocked during loader operation.

Avoid abrupt start, braking, sharp turns and long-term frictional slip of tires at tractor operation with loader.

When tractor with loader travels along the public roads traffic regulations should be observed.

Before starting traveling along the public roads, raise loader in transport position and fix it properly.

It may be a problem of spontaneous lowering of loader. In this respect loader should be shifted in lowermost position and loader hydraulic control mechanism levers should be fixed in a proper manner after end of operation and before leaving the cab.

Mounting and dismounting of loader should be carried out on a level ground hard pad.

Driver operating tractor with loader, housing of which is full under load, must lower working attachment in a lowermost position, stop the engine, switch AB off and leave the cab urgently avoiding touching loader housing metal parts.

Before starting loading and unloading operations operator should carry out preparatory inspection of place of work, and take a look at rules and methods of operation depending on specific conditions.

It is forbidden to let other person to drive tractor with loader.

Before starting to drive or engage reverse it is necessary to set the signal and ensure there are no people in the area of loader operation.

Take special care while traveling in the enterprise territory (maximum speed should be determined by enterprise standards).

When driving tractor with loader keep watch over obstacles located over-head (wires, pipelines, arches and etc.).

When loader bucket is full avoid striking against obstacle behind load.

Taking of bulk materials should be carried out by slow cutting in stock pile and simultaneous turn of loader bucket.

Operator is not allowed to start operation on loads handling in the following cases:

- load weight is unknown;
- poor light in the area of operation, loads can hardly be seen;
- loader is not operated on solid hard and smooth surface (asphalt, concrete, paving blocks and etc.), or the territory is not cleaned from snow and ice, ice-covered ground is not sanded or covered with special agent in winter;
- slope of work area, where loader is to be operated exceeds 8 grades.

Stop loader operation in the following cases:

- tire puncture or insufficient tire pressure;
- detection of failure in steering, hydraulic and braking system;
- availability of extraneous noises and slap noises in engine, chassis, loader working attachments.

4.13.3 Information about mounting holes of tractor

In the present subsection data on availability of mounting holes of tractor which can be used by manufacturers of front loaders for loader installation, and also by manufacturer of tractors for installation of various equipment are set forth. The mounting holes arrangement scheme for tractor "BELARUS-1025.5" is shown in Figure 4.13.2. Parameters of mounting holes are listed in Table 4.10.

Table 4.10 – Parameters of mounting holes of tractor "BELARUS-1025.5"

Denomination	№ 1	№ 2	№ 3	№ 4	№ 5
Diameter	M16	M16	M16	M16	M16
Length	28	28	28	28	28
Denomination	№ 6	№ 7	№ 8	№ 9	№ 10
Diameter	M16	M16	M16	∅18	∅18
Length	28	28	28	20	20
Denomination	№ 11	№ 12	№ 13	№ 14	№ 15
Diameter	∅18	∅18	∅18	∅18	∅18
Length	20	20	20	20	20
Denomination	№ 16	№ 17	№ 18	№ 19	№ 20
Diameter	∅18	M16	M16	M16	M16
Length	20	20	20	20	20
Denomination	№ 21	№ 22	№ 23	№ 24	№ 25
Diameter	M16	M16	M16	M16	M16
Length	20	20	20	20	20
Denomination	№ 26	№ 27	№ 28	№ 29	№ 30
Diameter	M16	M22x1,5	M22x1,5	M22x1,5	M22x1,5
Length	20	54	54	54	54
Denomination	№ 31	№ 32	№ 33	№ 34	№ 35
Diameter	∅17	∅17	∅17	∅17	∅17
Length	174	174	174	174	174
Denomination	№ 36	№ 37	№ 38	№ 39	№ 40
Diameter	∅17	∅18	∅18	∅18	∅18
Length	174	14	14	14	14
Denomination	№ 41	№ 42	№ 43	№ 44	№ 44
Diameter	∅18	∅18	∅18	∅18	∅18
Length	14	14	14	14	14
Denomination	№ 45	№ 46	№ 47	№ 48	№ 49
Diameter	∅18	∅18	∅20	∅20	∅20
Length	14	14	14	14	14
Denomination	№ 50				
Diameter	∅20				
Length	14				

NOTES:

Sizes in Table 10 are given in mm. Holes 1...26 are right and left.

In course of mounted components installation ensure safety of bushings in holes 6 and 10. It is not recommended to use holes with bushings for coupling

Holes 13; 14; 17; 18; 21; 22 on the right side are used for installation of tank and muffler supports. Use holes 37...50 only for fixture of non load-bearing construction elements.

ATTENTION: IT IS NOT RECOMMENDED TO USE SIDE HOLES WITH BUSHINGS! MOUNTED LOADER COMPONENTS SHOULD NOT CAUSE BUSHING DESTRUCTION!

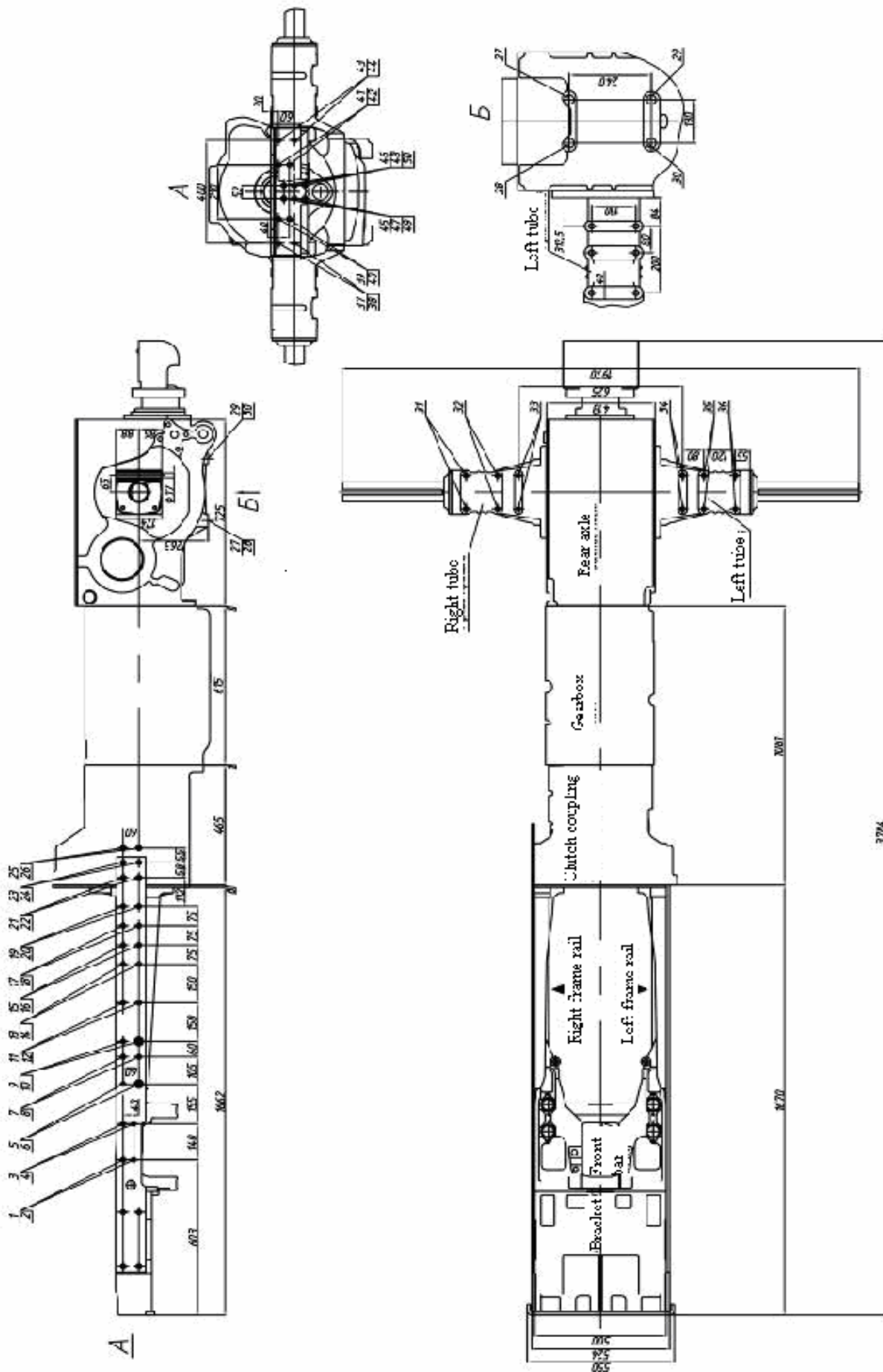

Figure 4.13.2 - Mounting holes arrangement scheme for tractor "BELARUS-1025.5"

5 MAINTENANCE

5.1 General instructions

Maintenance services (MS) is needed to maintain the tractor in operable state during operation. Non compliance with the specified intervals and bad quality of MS may result in reduction of tractor life, increase of failure number, engine power loss and increase in expenses for tractor operation. Operator must carry out daily inspection of the tractor, excluding fasteners torque-retention loss, fuel, liquid, and oil leakage, dirt and other deposits accumulation, which can cause operating troubles, ignition or accidents.

Notes about performance of maintenance services shall be made in the tractor service book.

Comply with storage precautions and waste recovery rules. Never discharge used liquid on the ground. Use special tanks for safe storage of waste.

WARNING: DURING CARRYING OUT OF MAINTENANCE AND REPAIR SERVICES COMPLY WITH SAFETY PRECAUTIONS, LISTED IN SUBSECTION 5.6 "SAFETY PRECAUTIONS IN THE COURSE OF MAINTENANCE AND REPAIR SERVICES"!

ATTENTION: IF THERE IS NO SPECIAL INSTRUCTIONS, BEFORE STARTING ANY MAINTENANCE OR ADJUSTMENT SERVICES, ETC., STOP THE DIESEL ENGINE AND ENGAGE PARKING BREAKS. IN CASE SAFETY GUARDS AND COVERS ARE OFF, ENSURE THEY ARE MOUNTED BACK AFTER MAINTENANCE SERVICES HAS COMPLETED, BEFORE YOU START OPERATING THE TRACTOR!

During hydraulic lift system, steering, and transmission line hydraulic system maintenance services, oil change and filters replacement intervals should be observed. It is not allowed to use oil, not specified in the tractor operation manual for filling (refilling).

Before refilling and replacement of filter cartridges clean filler plugs, necks, and caps, and adjoining surfaces from dirt and dust. During replacement of filter cartridges, wash the internal surfaces of filter housings and caps with the diesel fuel.

When the tractor is coupled with hydraulically-operated implements, clean clutches, couplings, adapting pipes and other connecting parts of the implement and the tractor thoroughly.

In case the hydraulic system is operated with hydraulically-operated implements filled with oil origin of which is unknown, the oil in the implement must be replaced by the oil, primed into the tractor hydraulic lift system.

Purity of the hydraulic system oil ensures its fail-safe operation.

Types of scheduled maintenance service are shown in Table 5.1.

Table 5.1 – Types of scheduled maintenance service

Types of maintenance service	Intervals, h
Maintenance service during operating run-in ¹⁾	MS before, during and after run-in (after 30 hours of operation)
Shift-time (STMS)	8-10
First maintenance service (MS-1)	125
Additional maintenance service (2MS-1)	250
Second maintenance service (MS-2)	500
Third maintenance service (MS-3)	1000
Special maintenance service	2000
General maintenance service	as it may be required
Seasonal maintenance service (MS-SS and MS-AW)	In course of transfer to autumn and winter operation (MS-AW) and spring and summer (MS-SS)
Maintenance service not corresponding to the set intervals with MS-1, 2MS-1, MS-2, MS-3 and special MS	–
Maintenance service in special operating conditions	During preparation of the tractor operation in special conditions
Maintenance service or storage ²⁾	In case of long-term storage

¹⁾ Data on the maintenance services, carried out by the operator before, during and after the tractor run-in are shown in subsection 3.4 “Further assembly and run-in of tractor”.

²⁾ Data on maintenance services performed by the operator on long storage of the tractor are shown in section 7 “Tractor storage” of the operation manual.

Deviation of + 10% for MS-1, 2MS-1 and MS -2 and 5% for MS -3 from the set intervals of MS are permitted (advancing or delayed MS) depending on the operating conditions for the chassis.

5.2 Providing access to the components for maintenance services

Before starting any maintenance work, raise, then lock the tractor hood and, if necessary, remove the both sides (Figure 3.1). To do that, proceed as follows:

- pull the handle 2 (Figure 5.2.1) and raise the hood 1 by the grip 3;
- lock the hood 1 with the rod 4;
- make sure that the hood 1 is securely locked in the raised position;
- if necessary, remove the left side 6 and the right side 5, first unscrewing three mounting bolts 7 on each side.

To provide access to the HLL tank, open the hatch 8 (Figure 5.2.1), first unlocking the lock 9.

DO NOT OPEN THE HOOD 1 (FIGURE 5.2.1) AND THE HATCH 8 AT THE SAME TIME.

Mechanism of opening the hood and locking it open

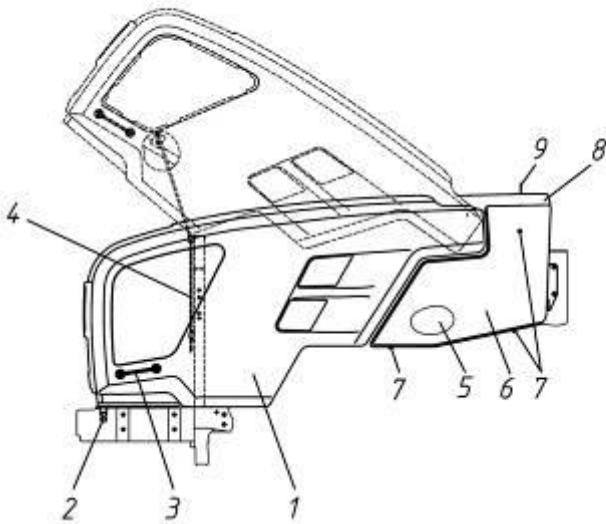

Mechanism of opening the hatch

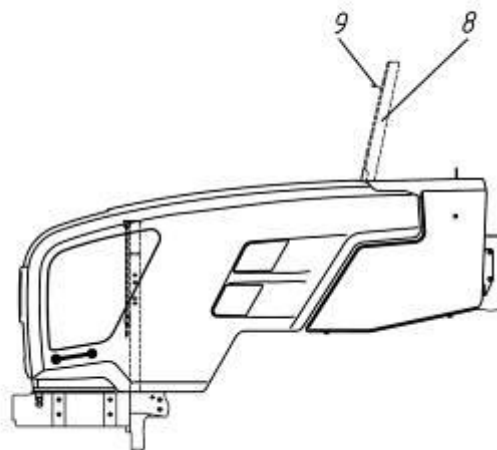

1 – hood; 2 – handle; 3 – grip; 4 – rod; 5, 6 – sides; 7 – bolt; 8 – hatch; 9 – lock.

Figure 5.2.1 – Mechanism of opening the hood and the hatch, locking the hood open

5.3 Maintenance procedure

Contents of scheduled servicing operations for tractors "BELARUS-1025.5" in course of operation are listed in Table 5.2.

Table 5.2

Operation No	Operation description	Periodicity, h					
		8-10	125	250	500	1000	2000
1	Check oil lever in engine case	X					
2	Check oil level in the transmission line	X					
3	Check oil level in an tank of HLL	X					
4	Check oil level in an tank of HSC	X					
5	Check of cooling liquid level in the engine cooling system	X					
6	Check tires state	X					
7 ¹⁾	Check air conditioner hose fixtures	X					
8	Inspect hydraulic system components	X					
9 ¹⁾	Inspect/clean air conditioner drainage pipes from the condensate water	X					
10 ¹⁾	Inspect/clean air conditioner condenser	X					
11	Inspect/clean engine water radiator and engine CAC-radiator	X					
12 ²⁾	Check/rinse of gripper tools of RLL	X					
13	Check breaks functioning in running order, engine, steering, light/alarm devices operability	X					
14	Drain condensate water from the pneumatic system balloon	X					
15	Check the condition of the wiring, wire bundles in the engine compartment, in the cab front area, and the condition of visible parts of the wiring	X					
16	Drain condensate water from the radiator tanks of CAC	X winter	X summer				
17 ³⁾	Check threaded joint torquing of wheels mounting	X	X				
18	Wash tractor and clean cabin inside surfaces		X				
19	Check bolts torquing of air duct clamps of CAC		X				
20 ⁴⁾	Check pneumatic pressure in tires		X				
21	Drain sediment from a fuel tank		X				
22	Drain sediment from coarse fuel filter		X				
23	Clean filter cartridges of ventilation and air heating systems		X				
24	Lubricate pivot axis bearing of FDA		X				
25 ¹⁾	Check/adjust air conditioner compressor drive belt tension		X				
26 ⁵⁾	Carry out maintenance of AB			X			
27	Lubricate HSC hydraulic cylinders hinged joints			X			
28	Rinse mesh filter of transmission hydraulic system			X			

Table 5.2 continued

Operation No	Operation description	Periodicity, h					
		8-10	125	250	500	1000	2000
29	Check/adjust clearances in steering link joints			X			
30	Check and adjustment of front wheels toe-in			X			
31	Lubricate clutch release yoke bearing			X			
32	Clean rotor wheel of centrifugal oil filter of GB			X			
33	Replace oil filter of the engine			X			
34	Replace oil in the engine crankcase			X			
35	Check/tighten bolt joints of brawbar hitch			X			
36	Drain sediment from the fine fuel filter			X			
37	Provide maintenance for alternator			X			
38	Check/adjust free travel of clutch pedal			X			
39	Clean filter cartridge of air pressure regulating filter in the pneumatic system				X		
40	Adjust service brake control				X		
41	Adjust parking brake control				X		
42	Check pneumatic system line proofness				X		
43	Check/adjust pneumatic system brake valve actuator				X		
44	Check all joints of air cleaner and inlet duct for hermiticity				X		
45	Check/adjust wheel-hub drive bearings of FDA				X		
46	Check/adjust bearings of pivot axis of FDA wheel-hub drives				X		
47 ⁶⁾	Check oil level in the housings of the brakes, operating in oil sump				X		
48	Check/adjust clearances between valves and rocker arms of the engine				X		
49	Check oil level in the main axle drive housing and in FDA wheel gear groups				X		
50 ⁷⁾	Replace exchangeable filter cartridge of HLL				X	X	
51 ⁷⁾	Replace exchangeable filter cartridge of HSC tank				X	X	
52	Change oil in HLL tank					X	
53	Change oil in HSC tank					X	

Table 5.2 finished

Operation No	Operation description	Periodicity, h					
		8-10	125	250	500	1000	2000
54	Change oil in transmission line					X	
55	Change oil in the main gear housing and wheel-hub drive casing of the FDA					X	
56 ⁶⁾	Replace oil in the housings of the brakes, operating in oil sump					X	
57 ⁸⁾	Grease the mechanism of gear links of the rear lift linkage					X	
58	Change grease in steering joints and rinse the steering joints components					X	
59	Check/adjust pneumatic pressure regulator					X	
60	Check/tighten the cylinder head attaching bolts					X	
61	Replace filter cartridge of coarse fuel filter					X	
62	Check/retorque of tractor external threaded joints					X	
63	Wash the engine cooling system and replace the coolant in the engine cooling system						X
64	Replace filter cartridge of fine fuel filter	Every 600 hours of operation or once in a year					
65 ¹⁾	Replace filter-drier of the air-conditioning system	Every 800 hours of operation or once in a year					
66	Perform complex servicing of "COMMON RAIL" system	Every 3000 hours of operation or once in a year					
67	Adjust the valve adjusting operating pressure in the hydraulic system of transmission, located the gearbox centrifuge	In case of abnormality of oil pressure value in transmission hydraulic system					
68	Adjust oil pressure in the engine lubrication system	In case of abnormality of oil pressure value in engine					
69	Carry out maintenance of engine air cleaner	As it becomes dirty					
<p>¹⁾ The operation is performed when the tractor is equipped with air conditioner instead of fan-heater.</p> <p>²⁾ The operation is performed when the tractor RLL is equipped with lower links with gripper tools.</p> <p>³⁾ Operation shall be carried out once during the first maintenance on a shift basis (in every 8-10 hours), which is carried out by the customer and hereinafter in 125 hours of tractor operation.</p> <p>⁴⁾ Control and bringing to the internal pressure norm in the tractor tires is carried out each time when one mode of the tractor operation is changed in another operation mode, and when the implements and tools coupled with the tractor are replaced.</p> <p>⁵⁾ AB inspection and maintenance shall be carried out once per 3 months and not less.</p> <p>⁶⁾ The operation is performed when the tractor is equipped with brakes operating in oil sump, against order.</p> <p>⁷⁾ First and second change is carried out in 500 hours of tractor operation. Then the change shall be carried out in every 1000 hours of operation simultaneously with oil change.</p> <p>⁸⁾ If screw lifting rods are installed against order the operation is not performed.</p>							

5.4 Scheduled maintenance servicing operations

5.4.1 Maintenance on a shift basis (SBMS) in every 8 – 10 hours of operation or per shift

5.4.1.1 General guidelines

Every 8 – 10 hours of the tractor operation or at the end of a shift (whichever comes first) perform the following operations:

5.4.1.2 Operation 1. Check of oil level in engine crankcase

Check oil level having put the tractor on a flat surface and not earlier than in 3 to 5 min after the engine is killed, when the oil completely runs down to the crankcase.

To check oil level in the engine crankcase proceed as follows:

- take a dipstick 3 out (Figure 5.4.1), wipe it clean and then put it back against the stop;

Take the dipstick 3 out and define the oil level. The level shall stay between the upper and the lower marks of the dipstick. If required top up the oil through a neck 1, having removed a cover 2.

- put the cover 2 back.

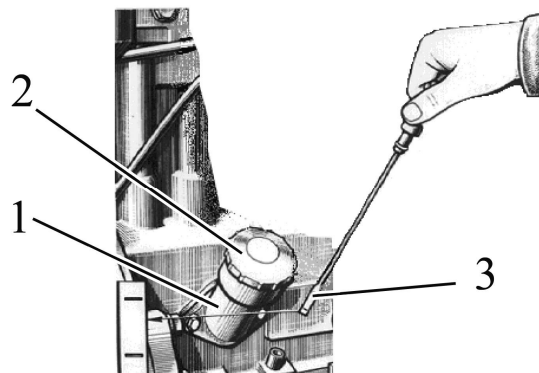

1 – filler neck; 2 – cover; 3 – dipstick.

Figure 5.4.1 – Check of oil level in engine crankcase

ATTENTION: DO NOT RUN THE ENGINE WITH THE OIL LEVEL BELOW THE LOWER MARK ON THE DIPSTICK!

ATTENTION: DO NOT TOP OIL ABOVE THE UPPER MARK OF THE DIPSTICK. THE OIL WILL BURN OUT CREATING ERRONEOUS IDEA OF LARGE OIL CONSUMPTION!

5.4.1.3 Operation 2. Check of oil level in the transmission

Check oil level according to oil-level gauge 1 (Figure 5.4.2), which is located on the right side of GB housing. Oil level shall be up to the mark “П” \pm 5 mm. When necessary refill the oil up to the required mark “П” through oil filler, first opened a cap 2.

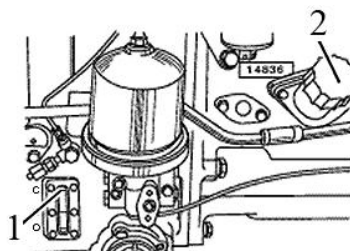

1 – oil-level gauge; 2 – oil filler cap

Figure 5.4.2 – Check of oil level in the transmission

5.4.1.4 Operation 3. Check of oil level in the HLL tank

Before checking the oil level set the tractor on the flat horizontal ground. Lower RLL links to the lowermost position. Stop the engine and put the parking brakes on.

Carry out visual inspection of the oil level according to the oil-level pointer 2 (Figure 5.4.3) on the tank 3. Level shall be between marks “O” and “П” of the oil level gauge. When necessary refill the oil up to the “П” mark through an oil filler opening, for which turn off the plug 2.

When tractor is operated coupled with implements with higher oil consumption, fill the oil up to mark “C” of the oil-level gauge with retracted rods of hydraulic cylinders of the implement coupled with tractor.

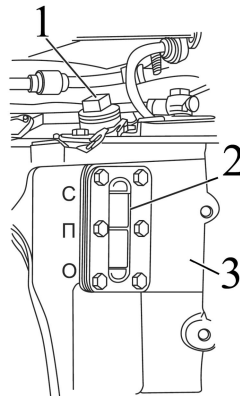

1 – oil filler plug; 2 – oil-level pointer; 3 – HLL tank;

Figure 5.4.3 – Check of oil level in the HLL tank

ATTENTION: OIL LEVEL CHECKING OPERATIONS IN THE HYDRAULIC LIFT LINKAGE TANK SHALL BE CARRIED OUT ONLY WITH THE RETRACTED ROD OF RLL HYDRAULIC CYLINDERS, AND CYLINDERS OF THE IMPLEMENTS COUPLED WITH THE TRACTOR!

5.4.1.5 Operation 4. Check of oil level in the HSC tank

Before checking the oil level in HSC tank 1 (Figure 5.4.4) set the tractor on the flat horizontal ground. Stop the engine and put the parking brakes on.

Check oil level by oil dipstick 3. Level shall be between upper and lower marks of the oil dipstick. When necessary turn off plug 2 of oil filler and refill oil up to the upper mark of the oil dipstick. Place plug 2 back in its place.

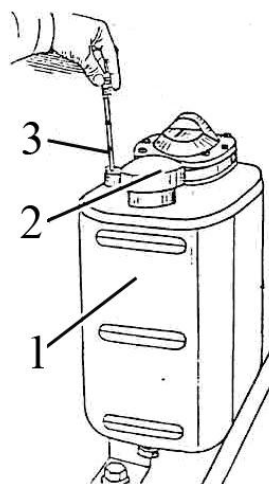

1 – HSC tank; 2 – plug; 3 – oil dipstick

Figure 5.4.4 – Check of oil level in the HSC tank

5.4.1.6 Operation 5. Check of cooling liquid level in the engine cooling system

The coolant level in the engine cooling system shall be controlled by fullness of the expansion tank 3 (Figure 5.4.5). The coolant quantity in the expansion tank shall stay at the level of 20 to 30 mm from the expansion tank bottom to the upper edge of the clamp 5 fastening the expansion tank 3. If the coolant level is lower than 20 to 30 mm from the expansion tank bottom, add the coolant to the expansion tank up to the upper edge of the clamp 5 fastening the expansion tank.

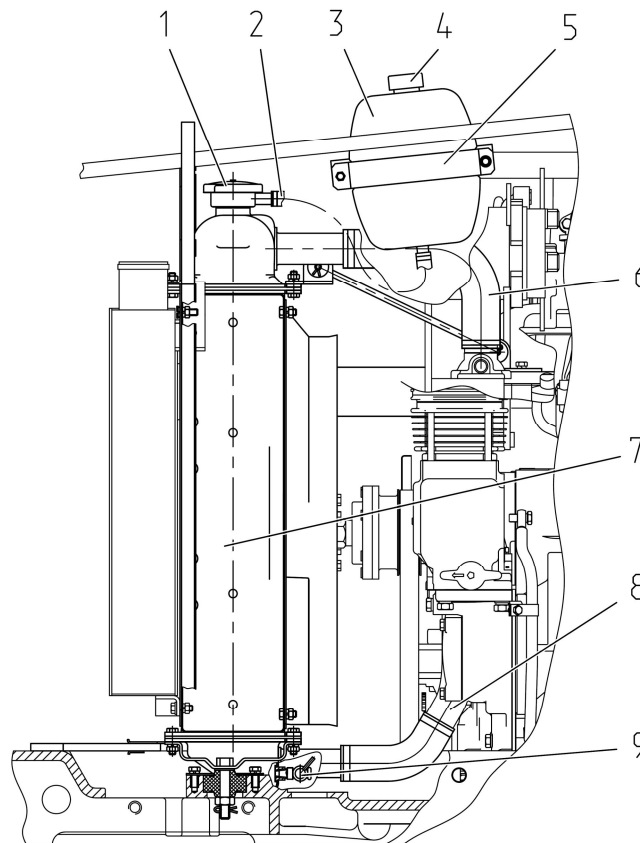

1 – water radiator plug; 2 – steam outlet and expansion pipe; 3 – expansion tank; 4 – expansion tank plug; 5 – fastening clamp for expansion tank; 6 – pipe from water radiator to the engine; 7 – water radiator; 8 – pipe from the water pump of the engine to the water radiator; 9 – drain cock.

Figure 5.4.5 – Check of cooling liquid level in the engine cooling system

WARNING: ENGINE COOLING SYSTEM WORKS UNDER PRESSURE WHICH IS MAINTAINED BY A VALVE LOCATED IN EXPANSION CHAMBER PLUG. IT IS DANGEROUS TO REMOVE THE PLUG WHEN THE ENGINE IS HOT. LET THE ENGINE COOL DOWN, COVER THE PLUG WITH DENSE TEXTURE AND TURN IT SLOWLY TO REDUCE PRESSURE IN A SMOOTH MANNER BEFORE REMOVING THE PLUG. AVOID BURNS BY HOT FLUID!

5.4.1.7 Operation 6. Check of tires state

Carry out inspection of outside appearance and conditions of the tires in order to detect faults or objects getting stuck in the tires (tacks, rocks and etc.). If necessary clear the tires of the foreign objects. In case the tires have defects going up to the tire fabric or cracks, going through the whole tire thickness, dismount the tire and send it to the special repair workshop for retreading. If the tires have defects is beyond repair, replace the tire. Defective tire shall be sent to recycling.

5.4.1.8 Operation 7. Check air conditioner hose fixtures

Note – Operation shall be carried out when the tractor is equipped with air conditioner instead of fan-heater.

Carry out visual inspection of air conditioner hose fixtures. Air conditioner hoses shall be properly fixed with coupling bands. The hoses shall not be in contact with moving parts of the tractor.

5.4.1.9 Operation 8. Inspection of hydraulic system components

Carry out inspection of the tractor hydraulic system components, when the condensation and downflows are detected eliminate them by means of threaded joints retorque. Change failed hoses and high pressure hoses.

5.4.1.10 Operation 9. Inspect/clean air conditioner drainage pipes from the condensate water

Note – Operation shall be carried out when the tractor is equipped with air conditioner instead of fan-heater.

Light-blue drain pipes are placed to the right and to the left of the heating and cooling device under the under ceiling panel. To avoid clogging the drain pipes shall be checked and cleared when necessary. Cleanness of a drain pipe is indicated by water dripping when the work air conditioner is used in hot weather.

5.4.1.11 Operation 10. Inspect/clean air conditioner condenser

Note – Operation shall be carried out when the tractor is equipped with air conditioner instead of fan-heater.

Check cleanness of air conditioner condenser core. If it is clogged, it is necessary to clean the condenser with a compressed air. Open the hood and direct an air flow perpendicular to the condenser plane from top downward. Jammed finning must be planished by means of special comb or plastic (wooden) plate. In case of severe condenser clogging rinse it with hot water under pressure not more than 0.2 MPa and blow it off by compressed air. Condenser cores must be cleaned both from the hood mask side and from the engine fan side.

CORROSIVE DETERGENT COMPOSITION MUST NOT BE USED!

5.4.1.12 Operation 11. Inspect/clean the engine water radiator and the engine CAC-radiator.

Check cleanness of the hood mask, engine CAC-radiator core and engine water radiator. In case it is clogged perform the following actions:

- carry out cleaning of hood mask with compressed air at both sides;
- carry out the CAC-radiator cleaning with the compressed air. Direct an air flow perpendicular to the CAC-radiator plane from top downward. In case of severe CAC-radiator clogging rinse it with hot water under pressure not more than 0.2 MPa and blow it off by a compressed air;
- carry out the water radiator cleaning with the compressed air. Direct an air flow perpendicular to the water radiator plane from top downward. In case of severe water radiator clogging rinse it with hot water under pressure not more than 0.2 MPa and blow it off by a compressed air;
- radiator cores must be cleaned both from the hood mask side and from the engine fan side;

ALKALINE SOLUTIONS AND CORROSIVE DETERGENT COMPOSITION MUST NOT BE USED!

5.4.1.13 Operation 12. Check/rinse of gripper tools of RLL

Note – The operation is carried out when the tractor rear lift linkage is equipped with lower links with gripper tools.

Check the pockets where the hinged joint locking mechanism in the gripper tools 1 (Figure 5.4.6) of the RLL are located. In case of dirt accumulation, clear the internal pockets and rinse it with water.

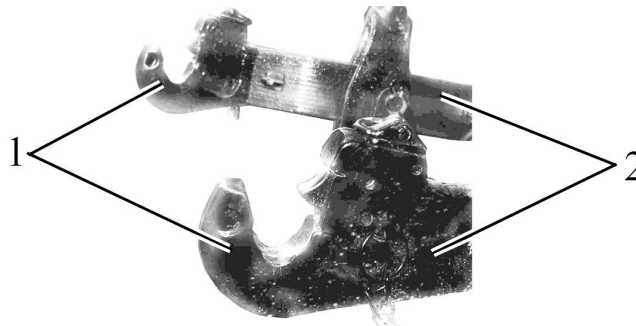

1 – gripper tool; 2 – link.

Figure 5.4.6 – Gripper tool of RLL

5.4.1.14 Operation 13. Check breaks functioning in running order, the engine, steering, light/alarm devices operability. Check of condition of electrical cables in the engine compartment

The following tractor operating parameters shall be ensured:

- the engine must operate properly in all modes;
- control elements, light warning and acoustic alarm devices must operate properly;
- simultaneous engagement of the right and left service brake.

In case the abovementioned conditions were not observed adjust as required or perform repair of the required tractor systems.

5.4.1.15 Operation 14. Drainage of the condensate water from the pneumatic system balloons

To condensate drainage from the both balloons 2 (Figure 5.4.7) of the pneumatic system pull the ring drain valve ring 1, installed on each balloon towards the horizontal direction of any side and hold it until full drainage of condensate.

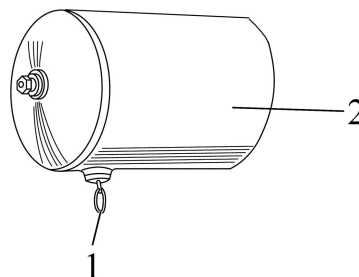

1 – ring; 2 – pneumatic system balloon.

Figure 5.4.7 – Drainage of the condensate water from the pneumatic system balloon

5.4.1.16 Operation 15. Check of the condition of the wires and wire bundles of the electrical equipment in the engine compartment, in the cab front area, and the condition of visible parts of the wiring

Review the condition of the wiring, wire bundles in the engine compartment, in the cab front area, and the condition of visible parts for abrasion, melt or damage of outer insulation.

Should the above faults be discovered, proceed as follows:

- restore the damaged areas using insulation tape;
- eliminate the cause that has lead to insulation damage;

5.4.1.17 Operation 16. Drainage of the condensate water from the radiator tanks of diesel CAC

Operation shall be carried out during the autumn and winter period in every 8-10 hours of the tractor operation or in shift time basis, and in spring and summer period – in every 125 hours of the tractor operation.

In order to drain the condensate water from the radiator tank of the diesel CAC it is necessary to perform the following actions:

- turn off two plugs 1 (Figure 5.4.8) in the bottom of the CAC radiator 2;
- let the condensate drain away;
- screw the plug 1.

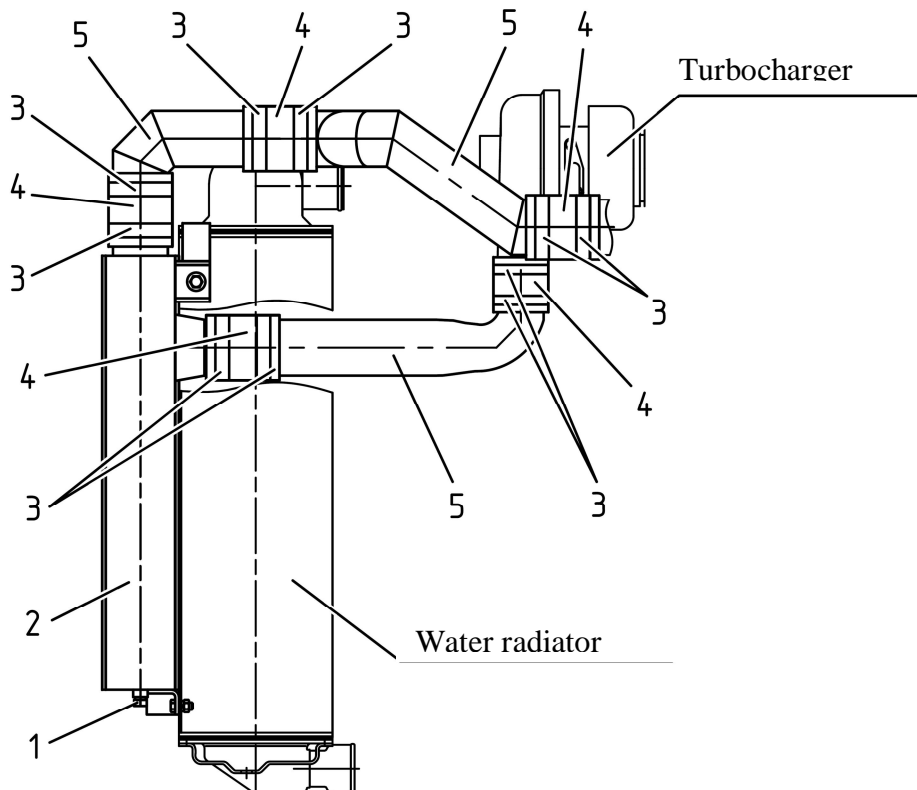

1 – plug; 2 – charged air cooler (CAC); 3 – clamps; 4 – high-temperature silicone fitting pipes; 5 – air pipes.

Figure 5.4.8 – Maintenance of engine CAC

5.4.2 Maintenance services in every 125 hours of operation

5.4.2.1 General guidelines

Perform the following operations and the operations, listed in this subsection 5.4.2.

5.4.2.2 Operation 17. Check of threaded joint torquing of wheels mounting

Check threaded joint torquing of wheels mounting shall be carried out one time along with first MS on a shift basis (in 8-10 hours of operation), which is carried out by a customer and then in every 125 hours of operation.

Check the torquing of torquing wheel nuts and hub bolts, and, if necessary, tighten them up:

- tightening torque for bolts 2 (Figure 5.4.9) of the rear wheel terminal hubs shall make 300 to 400 Nm (four bolts for each hub). If taper hubs are mounted, then the tightening torque for bolts 2 of the taper hubs shall be 360 to 450 Nm;
- tightening torque of nuts 3 for rear wheels mounting on hubs shall be from 300 to 350 Nm;
- tightening torque of nuts 1 for front wheels mounting on reducing gear flanges of FDA shall be from 200 to 250 Nm;
- tightening torque of nuts 5 for front wheels disks mounting on the rim brackets shall be from 180 to 240 Nm.

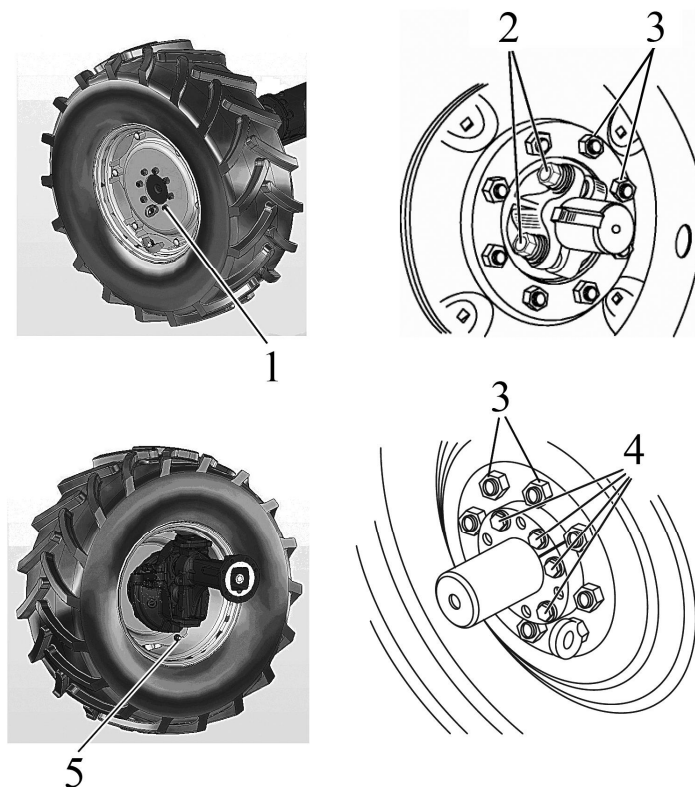

1 – nuts for front wheels mounting on reducing gear flanges of FDA; 2 – bolt for fastening rear wheel terminal hubs; 3 – nuts for rear wheels mounting on hubs; 4 – bolt for fastening rear wheel taper hubs; 5 – nuts for front wheels disks mounting on the rim brackets.

Figure 5.4.9 – Check of threaded joint torquing of wheels mounting

5.4.2.3 Operation 18. Washing of the tractor and cleaning of the cabin inside

Wash the tractor and clean the cabin inside.

Before washing the tractor with water jet stop the engine, put the battery disconnect switch in "OFF" position.

During tractor washing take steps to protect the electronic components, plugs and sockets against entry of water jets. Water jet must not be pointed at electric and electronic work-pieces, cables connectors.

Maximum water temperature shall not exceed 50⁰C. It is forbidden to add corrosive agents (detergents).

After the tractor washing clear the electric and electronic work-pieces and cables connectors with a compressed air.

5.4.2.4 Operation 19. Check of bolts torquing of air duct clamps of CAC

Check and tighten the clamp bolts 3 (Figure 5.4.8) of CAC air ducts, if necessary, with torque from 5 to 8 N·m

ATTENTION: AFTER CHECKING THE TORQUE OF THE CLAMP BOLTS IT IS REQUIRED TO CHECK HERMITICITY OF ALL JOINTS OF CAC DUCT, TO DO THIS INSPECT CONNECTIONS OF ALL AIR PIPELINES AND SILICONE PIPES OF THE CAC SYSTEM FOR DAMAGES AND LEAKAGES. SHOULD ANY FAULTS OR DAMAGES BE DISCOVERED FIND OUT THEIR REASON AND TAKE MEASURES TO ELIMINATE THEM!

IT IS FORBIDDEN TO RUN THE TRACTOR WITH THE CAC SYSTEM FAULTY!

5.4.2.5 Operation 20. Check of pneumatic pressure in tires

Pressure in the front and rear tires is determined from load per single tire, driving speed and operations performed. If it is necessary bring the pressure up to the required value in compliance with subsection 3.2.8 "Selection of optimal internal pressure in tires, depending on the operating conditions and load on the tractor axles".

ATTENTION: CONTROL AND BRINGING THE TIRES INTERNAL PRESSURE UP TO THE NORMAL VALUE, WHEN NEEDED, SHALL BE CARRIED OUT EACH TIME THE TRACTOR IS CONVERTED FROM ONE OPERATION TO ANOTHER AND IS REEQUIPPED WITH OTHER IMPLEMENTS ANA INSTRUMENTS COUPLED!

5.4.2.6 Operation 21. Drain of the sediment from fuel tank

To drain the sediment from the fuel tank it is necessary to perform the following:

- screw out the tank adapter 1 by a screw key S 17 (Figure 5.4.10), holding metallic embedded part of the fuel tank 2 by a screw key S 24 (the tank adapter 1 is placed in the bottom of the fuel tank 2);

- drain the sediment until the clean fuel will appear;

- after the clear fuel without water and dirt appearance screw in the tank adapter 1, holding metallic embedded part of the fuel tank 2.

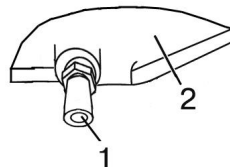

1 – tank adapter; 2 – fuel tank.

Figure 5.4.10 – Drainage of the sediment from the fuel tank

5.4.2.7 Operation 22. Drain of the sediment from coarse fuel filter

To drain the sediment from coarse fuel filter it is necessary to perform the following:

- open drain cock 1 (Figure 5.4.11) of coarse fuel filter 3;
- drain the sediment until the clean fuel will appear, collect sediment in special container;
- after appearing of clean fuel without water and drain, close drain cock 1.

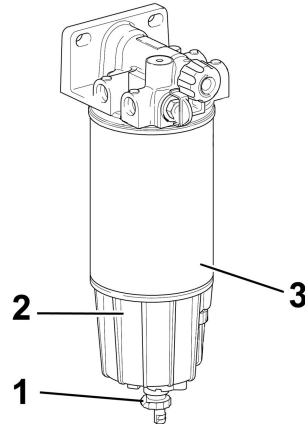

1 – drain cock; 2 – catch water bowl; 3 – coarse fuel filter.

Figure 5.4.11 – Drainage of the sediment from coarse fuel filter

ATTENTION: IF DURING OPERATION THE MESSAGE ABOUT PRESENCE OF WATER IN COARSE FUEL FILTER APPEARED IN THE INFORMATIONAL DISPLAY UNIT, DRAIN THE SEDIMENT FROM COARSE FUEL FILTER NOT WAITING FOR THE DAY OF REGULAR MAINTENANCE!

5.4.2.8 Operation 23. Cleaning of the filter cartridges of ventilation and air heating systems

To clean the ventilation system and cabin heating filter it is necessary to perform the following:

- raise the cab roof 1 (Figure 5.4.12).
- undo two fastening bolts and remove the filter cap 2 together with two filtering cartridges 3.
- shake the cartridges slightly to remove free particles of dust from the filter; be cautious so that not to damage the filter.
- clean the filters with compressed air under the pressure of not higher than 0.2 MPa. Hold the tube cap at the distance not closer that 300 mm from the filter so that not to damage the paper filter cartridge. Send air flow through the filter in the direction which is reverse to the normal air flow traffic, shown by arrows marked on the filter.
- mount the filter performing the operations in the reverse order, close the cab roof.

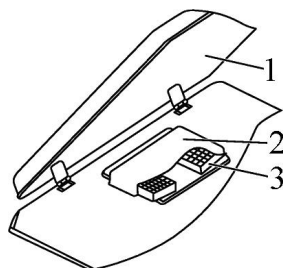

1 – cab roof; 2 – filter cap; 3 – filter cartridge

Figure 5.4.12 –Cleaning of the filter of ventilation and cab heating systems

ATTENTION: DO NOT SWITCH THE FAN ON BEFORE CLEANING THE FILTERS AT HIGH HUMIDITY OF THE ENVIRONMENT FOR EXAMPLE IN THE MORNING, AS IT IS HARD TO REMOVE DUST FROM A WET PAPER FILTER CARTRIDGE!

ATTENTION: DURING THE TRACTOR OPERATION IN HEAVY DUSTING CONDITIONS CLEAN THE FILTER IN EVERY 8-10 HOURS OF OPERATION, I.E. ON A SHIFT BASIS!

5.4.2.9 Operation 24. Lubricate pivot axis bearing of FDA

To oil pivot axis bearing 3 perform the following:

- remove the caps 1 (Figure 5.4.13) from four lubricating boxes 2 and bearings 3;
- clean lubricating boxes 2 from accumulated dirt and consolidated lubricant;
- squirt lubricating boxes 2 with lubricant, performing six injections.

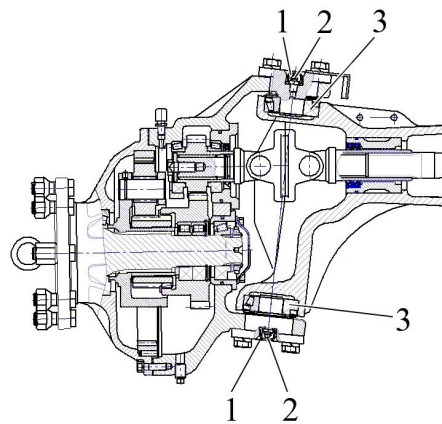

1 – cap, 2 – lubricating boxes; 3 – bearing.

Figure 5.4.13 – Lubricating pivot axis bearing of FDA

5.4.2.10 Operation 25. Check/adjust air conditioner compressor drive belt tension

Note – Operation shall be carried out when the tractor is equipped with air conditioner instead of fan-heater.

1 Check of air conditioner compressor drive belt tension:

Belt 1 tension (Figure 5.4.14) of air conditioner compressor drive is considered to be normal if bending deflection of its side “engine crankshaft pulley – compressor pulley” measured in the middle range within 4 to 6 mm with force of (39.2 ± 2.0) N applied.

In case the condition is not observed it is necessary to adjust air conditioner compressor drive belt tension.

2. Adjustment of air conditioner compressor drive belt tension:

Adjustment of belt 1 tension (Figure 5.4.14) shall be carried out by turning compressor 2 on rotational axis A and threaded joint clamp B in slot C. Belt bending deflection in response to force of (39.2 ± 2.0) N applied to the center of belt side must range within 4 to 6 mm.

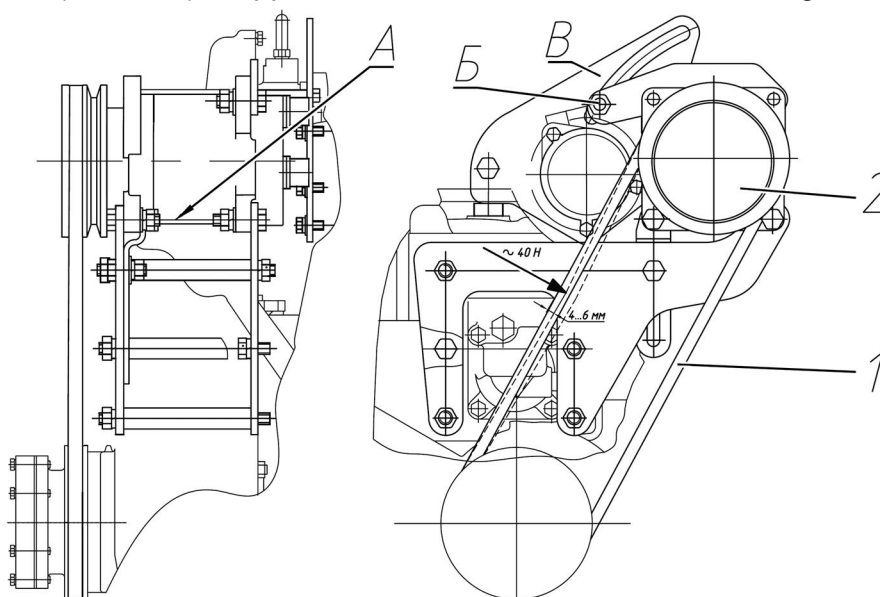

1 – belt; 2 – compressor.

Figure 5.4.14 – Adjustment of air conditioner compressor drive belt tension

5.4.3 Maintenance services in every 250 hours of operation (2MS-1), in every 500 hours of operation (MS-2), in every 1000 hours of operation (MS-3), in every 2000 hours of operation (special maintenance) and maintenance service that is inconsistent with intervals of MS-1, 2MS-1, MS-2, MS-3 and special MS

5.4.3.1 General instructions

ATTENTION: ONLY DEALERS ARE AUTHORIZED TO PERFORM OPERATIONS 2 MS-1, MS-2, MS-3 AND SPECIAL MAINTENANCE EXCEPT FOR THE OPERATIONS "CHECK / ADJUSTMENT OF FRONT WHEEL TOE-IN" AND "CHECK/ADJUSTMENT OF CLEARANCES IN STEERING JOINTS"!

The operations 2MS-1 shall be performed in every 250 hours of operation together with the operations of STM and TM-1.

The operations TM-2 shall be performed in every 500 hours of operation together with the operations of STM, TM-1 and 2TM-1.

The operations TM-3 shall be performed in every 1000 hours of operation together with the operations of STM, TM-1, 2TM-1 and TM-2.

The operations of special maintenance shall be performed in every 2000 hours of operation together with the operations of STM, TM-1, 2TM-1, TM-2 and TM-3.

5.4.3.2 Operation 29. Check/adjustment of clearances in steering joints

To check the backlash and clearances in steering joints 1 (Figure 5.4.16) of the steering link 4, it is necessary to turn the steering wheel either side when the engine is running. In case the steering wheel angular play is more than 25° as indicated in Figure 5.4.15, remove the steering joints play by performing the following actions:

- stop the engine;
- remove locking wire 3 (Figure 5.4.16);
- screw threaded plug 2 to remove the steering joints play;
- locknut plug 2 with wire 3.

If the steering joints play can not be eliminated by tightening of threaded joints, take the hinge joint to pieces and replace worn-out parts.

Besides, weak tightening of castle nuts of cone-shaped pins may be a reason for increased steering wheel play angle of HSC hydraulic cylinders.

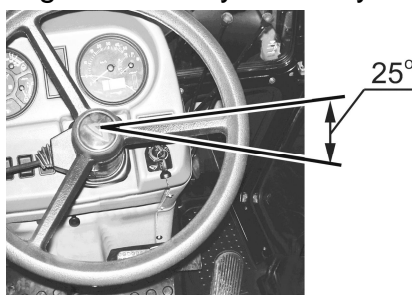
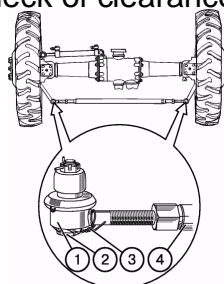

Figure 5.4.15 – Check of clearances in steering joints



1 – hinged joint; 2 – plug; 3 – locking wire; 4 – steering link.

Figure 5.4.16 – Maintenance of steering joints

5.4.3.3 Operation 30. Check and adjustment of wheels toe-in

Adjustment of front wheels toe-in is carried out to prevent the front tires from premature breakdown.

ATTENTION: CHECK AND ADJUSTMENT OF FRONT WHEELS TOE-IN SHALL BE CARRIED OUT IN EVERY 250 HOURS OF TRACTOR OPERATION, AND AFTER EACH TIME THE FRONT WHEELS TRACK WIDTH IS CHANGED. BEFORE CHECKING THE FRONT WHEELS TOE-IN, CHECK AND ADJUST, IF NECESSARY, THE STEERING JOINTS PLAYS!

To make adjustments, perform the following:

1. Set necessary tire pressure acc. to the subsection "Selection of optimal inner pressure in tires depending on operational conditions and load on tractor axles" of section 3 "Intended use of tractor".

2. Set the front wheels in straight position by way of running the tractor straight ahead for not less than 3 meters along the horizontal level ground. Engage the parking break to avoid tractor movement.

3. Measure distance "A" (Figure 5.4.17) on wheel centre level at the front and make visible marks in locations of measurements.

4. Disengage the parking break, drive the tractor ahead in such a way that the front wheels turn by half revolution and measure distance "B" between rim edges on wheel centre level from behind in the point determined and marked before.

5. If the value ("B"- "A") ranges within 0 to 8 mm that means that the toe-in is correctly adjusted. If the value ("B"- "A") is lower 0 or more than 8 mm, perform the following:

a) leaving the tractor position unchanged, unscrew nuts 1 and 3;

b) rotating steering link tube 2 try to get value ("B"- "A") ranging within 0 to 8 mm;

c) repeat operations, described in subclauses 4 and 5.

d) if value ("B"- "A") falls within the limits of 0 to 8 mm, tighten steering link nuts 1 and 3 with torque of 100 to 140 Nm, leaving steering link length unchanged.

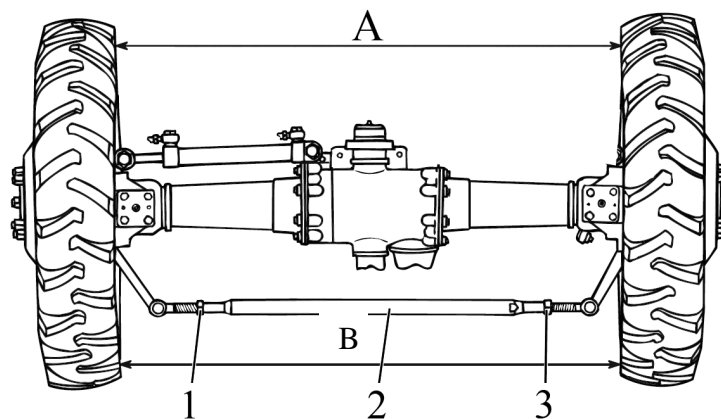

1, 3 – lock nut; 2 – adjustable steering link tube.

Figure 5.4.17 – Front wheels toe-in adjustment scheme

5.4.4 General maintenance services

5.4.4.1 General guidelines

Carry out maintenance service operations, listed in subsection 5.4.4 as may be necessary (i.e. when level sensor or dirtiness sensor responds).

5.4.4.2 Operation 67. Adjustment of valves of GB driven centrifuge

Valve 2 for adjustment of working pressure of transmission hydraulic system (Figure 5.4.18) maintains oil pressure in hydraulic system within the range 0.9 to 1.1 MPa. In case pressure in hydraulic system transmission (acc/ to gauge 1 in figure 2.6.1) falls below the specified limit adjust valve 2 (figure 5.4.18) by installation of auxiliary washers 5 between spring 3 and plug 6.

Valve 7 maintains oil pressure before centrifuge rotor. It should be from 0.77 to 0.83 MPa and can be adjusted by means of installation of washers 9. Lubrication valve 12 is adjusted for pressure from 0.2 to 0.25 MPa and maintains oil pressure in GB lubricating system. Valve adjustment can be performed by means of washers 11.

To increase pressure increase number of washers, to reduce pressure decrease number of washers.

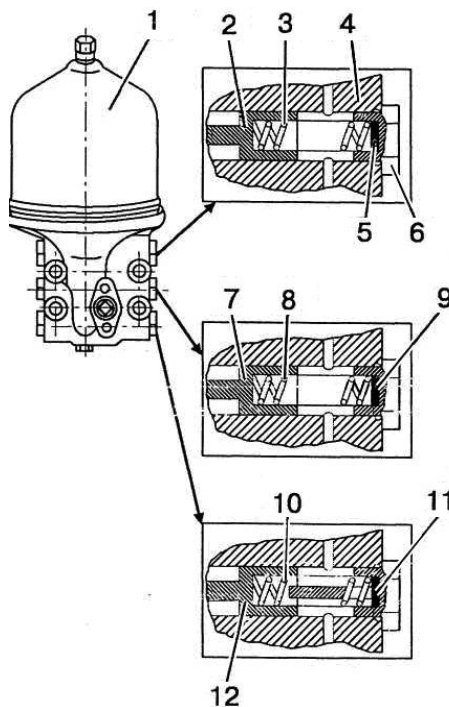

1 – GB driven centrifuge; 2 – valve for adjustment of working pressure of transmission hydraulic system; 3 – spring; 4 – casing; 5 – washer; 6 – plug; 7 – rotor valve; 8 – spring; 9 – washer; 10 – spring; 11 – washer; 12 – lubrication valve.

Figure 5.4.18 – Adjustment of valves of GB driven centrifuge

ATTENTION: IF PRESSURE FALLS UP TO 0.7 MPA STOP THE TRACTOR AND CORRECT FAILURE IN TRANSMISSION HYDRAULIC SYSTEM!

ATTENTION: HYDRAULIC PRESSURE IN THE TRANSMISSION HYDRAULIC SYSTEM SHALL BE ADJUSTED ONLY BY WAY OF ADJUSTING THE VALVE 2 (FIGURE 5.4.18). ONLY DEALERS ARE AUTHORIZED TO ADJUST THE VALVES 7 AND 12 WHEN PERFORMING REPAIR WORKS!

5.4.4.3 Operation 68. Adjustment of oil pressure in the engine lubrication system

Watch constantly oil pressure value in the engine lubrication system on the dial 10 in figure 2.6.1, located in the dashboard (as the engine is running with a rated speed and the coolant temperature is 85 to 95°C, the oil pressure shall stay at the level of 0.25 to 0.35 MPa, it is admitted that the pressure value be 0.6 MPa on the cold engine);

If the lubrication system is in good order (oil pipeline joints are tight, the safety valve in the oil filter is in good order, etc.), but the lubrication pressure value constantly exceeds 0.35 MPa or is constantly below 0.25 MPa during the engine running under rated speed with the normal coolant temperature, it is required to adjust oil pressure in the engine lubrication system.

Adjust the oil pressure in the engine lubrication system as follows:

- undo a plug 3 (Figure 5.4.19), remove a shim 4;
- using a screwdriver 6 turn an adjusting plug 5 in the channel of the oil filter body 2 by one turn to the side of increasing or decreasing the pressure value (depending on the actual pressure);
- mount the shim 4 and do the plug 3 in;
- if required repeat the above adjustment operations.

IT IS FORBIDDEN TO ADJUST OIL PRESSURE IN THE LUBRICATION SYSTEM AS THE ENGINE IS RUNNING.

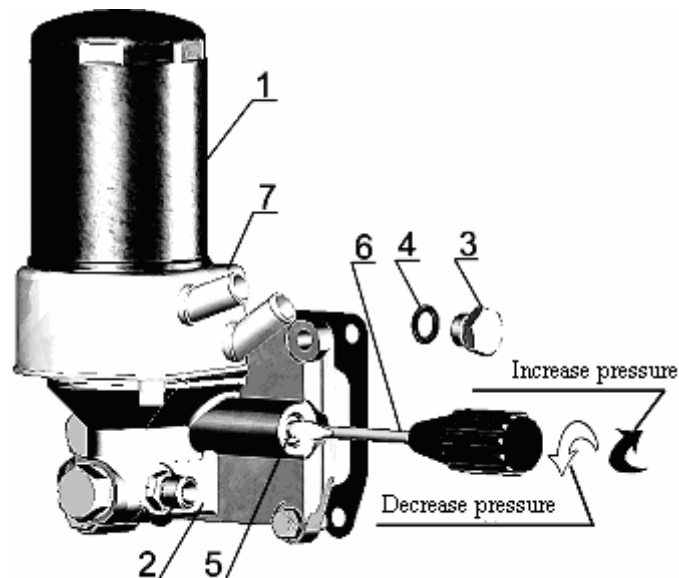

1 – oil filter; 2 – oil filter body; 3 – valve plug; 4 – plug shim; 5 – adjusting plug; 6 – screwdriver; 7 – liquid and oil heat exchanger.

Figure 5.4.19 – Adjustment of oil pressure in the engine lubrication system

5.4.4.4 Operation 69. Maintenance of engine air cleaner

Maintenance of engine air cleaner should be performed after air cleaner filter indicating lamp gets on, which is located in control indicator unit at instrument board. It means that the filtering element is out of its lifetime.

Note – Air cleaner can be equipped with one yellow locking device instead of some locking devices 1 of black color (Figure 5.4.20).

If the indicating lamp is on, replace main filter cartridge (MFC):

To replace MFC perform the following:

- open tractor hood mask to get access to air cleaner;
- pull black locking devices 1 (Figure 5.4.20), turn cover 2 counterclockwise and remove it;
- remove carefully main filter cartridge 3;
- check if there dirt in the master filter element 5 (MFE) without removing it from its housing 4.

ATTENTION: REMOVING THE MFC FROM ITS HOUSING IS NOT RECOMMENDED. DIRT IN THE MFC INDICATES A FAILED MAIN FILTER CARTRIDGE (BREAK OF THE PAPER SHUTTER, LOOSE BOND OF THE BOTTOM). IN SUCH CASE, RINSE THE MFE AND REPLACE THE MAIN FILTER CARTRIDGE!

- clear inside and sealing surface of housing 4 with wet cloth from dust and dirt.
- assembly of air cleaner with new main filter cartridge should be carried out in reverse order;
- ensure that installation of MFC is carried out correctly and close locking devices 1;
- place tractor hood mask back to its place.

ATTENTION: MANUFACTURER OF THE AIR CLEANER STRONGLY RECOMMENDS TO CARRY OUT MFC REPLACEMENT, RATHER THAN CLEANING, TO AVOID DAMAGE AND TO PROVIDE THE MAXIMUM PROTECTION OF THE ENGINE!

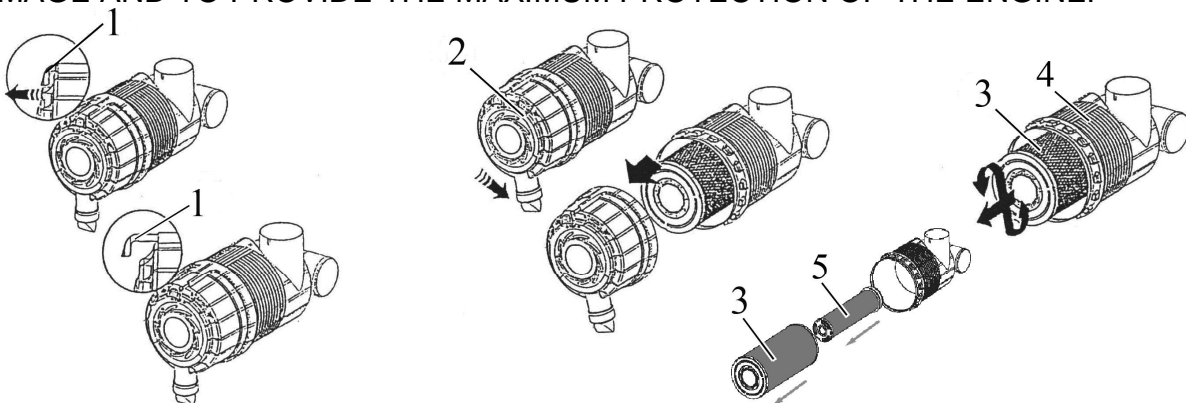

1 – locking device; 2 – cover; 3 – main filter cartridge (MFC); 4 – air cleaner housing; 5 – master filter element.

Figure 5.4.20 – Diesel engine air cleaner maintenance

If filter clogging indicating lamp has light up and there is no possibility to replace MFC at once, clearing of MFC is allowed.

- remove carefully main filtering cartridge 3;
 - blow over main filter cartridge carefully with cry compressed air inside-out until dusting is stopped. To avoid paper shutter break air pressure should be from 0.2 to 0.3 MPa. Point air stream at right angle to filter cartridge surface. During maintenance it is necessary to protect filter cartridge from mechanical damage and oiling-up;
 - check MFC for possible failures (shutter breakout, bottom coming unstuck);
 - wipe O-ring of MFC with wet cloth and install MFC into air cleaner housing
- Cleaned MFC do not have the same service life as a new one.

After 3 changes of MFC the master filter element shall also be changed.

IT IS FORBIDDEN TO BLOW OFF WITH EXHAUST GASES, RINSE AND DUST OFF MAIN FILTER CARTRIDGE!

ATTENTION: AFTER AIR DUCT CLEANER IT IS NECESSARY TO CHECK ALL INTAKE DUCT CONNECTIONS FOR TIGHTNESS.

To check tightness use the device KI-4870 GOSNITI or its equivalent. If the device is missing check the connection tightness visually. Damaged connection members should be replaced.

ATTENTION: TRACTOR OPERATION WITH UNSEALED INTAKE DUCT IS FORBIDDEN!

Depressurizing circuit for air supply to turbo-compressor can have adverse effect on reliability of clogging indicator readings, which can cause entering of some volume of unpurified air with heavy concentration of dust into cylinders via the turbo-compressor, resulting in accelerated depreciation of engine cylinder-piston group in case it enters the oil.

5.5 Seasonal maintenance services

Carrying out of seasonal maintenance service combine with performance of operations of the ordinary maintenance services. Scope of work which should be carried out during seasonal maintenance service, is listed in Table 5.3.

Table 5.3 – Seasonal maintenance services

Scope of work	
When changing into autumn-winter period (with fixed daily average temperature +5C°)	When changing into spring-summer period (with fixed daily average temperature above +5C°)
Replace in accordance with Table 5.4, summer oil grades by winter in transmission	Replace in accordance with Table 5.4, summer oil grades by winter in transmission
Replace in accordance with Table 5.4, summer oil grades by winter in engine crankcase	Replace in accordance with Table 5.4, summer oil grades by winter in engine crankcase

5.6 Safety measures during maintenance and repair operations

5.6.1 General safety requirements

It is forbidden to dismount the hood side panels and/or open the hood of the tractor with the engine running.

Maintenance (repair) operations shall be carried out only if the engine is not running and PTO is disengaged. Hinged implements shall be grounded, the tractor shall be stopped with the parking break.

Adhere to the safety requirements during application of the lift-and-carry means.

During inspection of units under control and adjustment use the portable lamp with voltage of 36V. The lamp shall be protected by wire guard.

Tools and accessories for MS shall be properly operating, answer the purpose and ensure safe operation.

In order to avoid injury be careful draining (refilling) the coolant from the engine cooling system, the hot oil from the engine, hydraulic systems of LL and HSC, transmission bodies, FDA reducing gears. Avoid contact with hot surfaces of the abovementioned units.

Mounting and dismounting of the engine shall be carried out by means of a rope, fastened to eye-bolts on the engine.

Do not make alterations in the tractor or its separate parts design without sanction of the manufacturing works. Otherwise the tractor after-sales service warranty is no longer valid.

5.6.2 Safety precautions for exclusion of hazardous situations, related to an accumulator battery and a fuel tank

Safety precautions for exclusion of hazardous situations, related to an accumulator battery and a fuel tank

During maintenance of the accumulator battery perform the following:

- avoid skin contact with electrolyte;
- clean the batteries with wiping material moistened with aqua ammonia solution (ammonium hydroxide);
- during examination of electrolyte level use distilled water only;
- do not check the battery charge condition by means of the terminal short circuit;
- do not connect the accumulator battery with reversed polarity.

In order to avoid damaging of the electronic units of the electrical facilities and electrical control systems adhere to the following safety precaution:

- do not connect the AB outputs with the engine running. It will cause the peak voltage in charging circuit and will result in inevitable failure of the diodes and transistors;
- do not disconnect the electric wires when the engine is running and electric switches are "on";
- do not cause short circuit by incorrect wires connection. Short circuit or incorrect polarity will result in failure of the diodes and transistors;
- do not connect the AB in the electrical facilities systems until the outputs/inputs polarity and voltage are checked;
- do not check the electric current by spark test as it can result in immediate breakdown of the transistors;

Repair operations associated with application of electric welding for the tractor shall be carried out while the AB switch is "off".

To avoid ignition or explosion hazard, prevent the fuel tank, engine fuel system and accumulator batteries from being close to the open flame sources.

5.6.3 Guidelines for safe use of leveling jacks and statement of places where they shall be installed

Use leveling jacks to lift tractor, and after lifting insert backing blocks and limit stops under the front axle beam, rear wheels semi-axes, or base components of the tractor frame.

Places for a leveling jack installation on the tractor are marked by a sign shown in Figure 5.6.1.

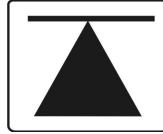

Figure 5.6.1 – Sign of a place for a leveling jack installation

To lift rear elements of the tractor set leveling jacks (or single jack) under the rear-axle tube as illustrated in Figure 5.6.2

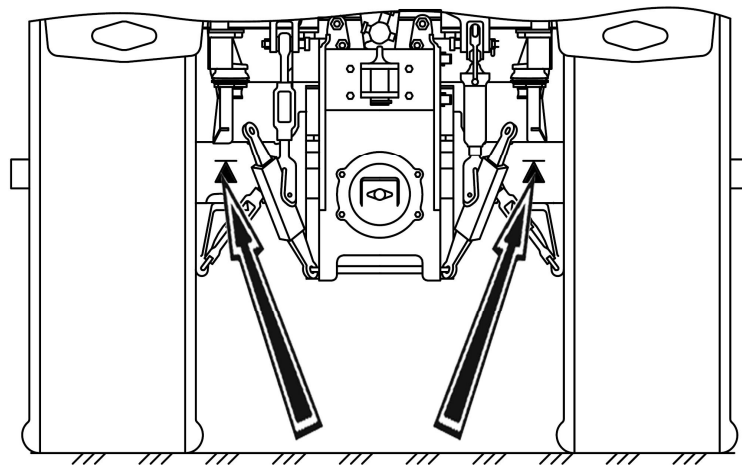

Figure 5.6.2 – Scheme of leveling jacks installation for lifting of the rear elements of the tractor

To lift front elements of the tractor set leveling jacks (or single jack) under the front driving axle beam tube as illustrated in Figure 5.6.3.

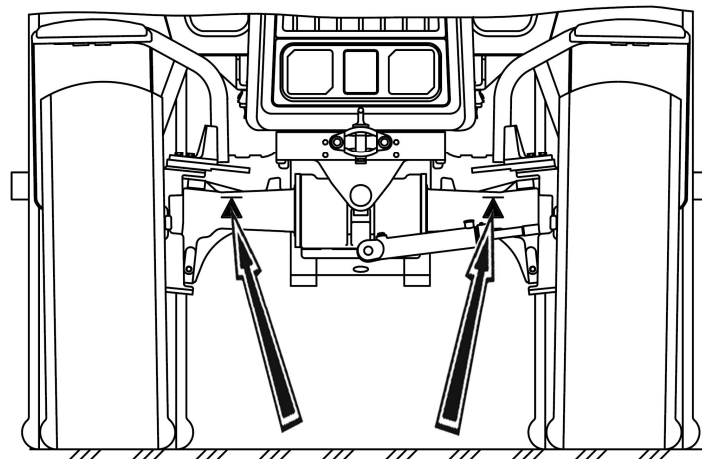

Figure 5.6.3 – Scheme of leveling jacks installation for lifting of the front elements of the tractor

When using leveling jacks comply with the following safety requirements:

- in the course of tractors "BELARUS-1025.5" lifting use properly operating leveling jacks with lifting capacity of 5 ton-forces only;
- before tractor jacking kill the engine and engage the parking break;
- in course of the front elements jacking put scotches under the rear wheels;
- in course of the rear elements jacking engage the gear and put scotches under the front wheels;
- do not put the jack on soft or slippery surface as it may cause the tractor fall off the jack. When needed, use steady and relatively large foot;
- after the tractor is lifted, insert the limit stops under the front axle beam, rear wheels semi-axles, or base components of the tractor frame, to exclude tractor fall or rolling movement.

IT IS FORBIDDEN TO START THE ENGINE WHEN THE TRACTOR IS JACKED.

ATTENTION: ONLY PERSONNEL PROPERLY INSTRUCTED ON SAFE USE OF LEVELING JACKS, AND HAVING LEARNED METHODS OF LEVELING JACK SAFE OPERATION ARE ALLOWED!

5.7 Filling and lubrication of the tractor with fuel and lubrication materials

In Table 5.4 titles and trademarks of fuel and lubrication materials (FLM) used during the tractor operation and maintenance are listed, their quantity and change intervals are also specified.

Table 5.4 – List of the tractor “BELARUS - 1025.5” FLM

Item reference	Title of the assembly unit	Quantity of assembly units, items.	Name and designation of fuel and lubrication materials				Weight (volume) of FLM, Filled in the tractor when change or refill	Change intervals FLM, hours	Remarks
			Basic components	Backup components	Auxiliary components	Foreign-made			
1	2	3	4	5	6	7	8	9	10
1 Fuels									
1.1 ¹⁾	Fuel tank	1	At ambient temperature of 0°C and more				(140±2)	Filled in every shift	
			Diesel fuel STB1658-2006 with sulfur content not exceeding 50 mg/kg (0.005%) Grade B	Not available	Not available	Diesel fuel EN 590:2004 with sulfur content not exceeding 50 mg/kg (0.005%)			
			At ambient temperature of minus 5 °C and more						
			Diesel fuel STB 1658-2006 with sulfur content not exceeding 50 mg/kg (0.005%) Grade C	Not available	Not available	Diesel fuel EN 590:2009 + A1:2010 with sulfur content not exceeding 50 mg/kg (0.005%)			
			At ambient temperature of minus 20 °C and more						
			Diesel fuel STB 1658-2006 with sulfur content not exceeding 50 mg/kg (0.005%) Grade F	Not available	Not available	Diesel fuel EN 590:2009 + A1:2010 with sulfur content not exceeding 50 mg/kg (0.005%)			
2 Oils									
2.1	Engine oil crankcase ²⁾	1	In summer				(12,0±0,18)	250	
			Engine oils «Shell Rimula R6 LM» SAE 10W-40, «Shell Rimula R4L» SAE 15W-40, «Castrol Enduron Low SAPS 10W-40»	Not available	Not available	Not available			
			In winter						
			Engine oil «Shell Rimula R6 LME» SAE 5W-30	Not available	Not available	Not available			

Table 5.4 continued

1	2	3	4	5	6	7	8	9	10
2.2	High-pressure fuel pump of the engine	1	Engine oil is the same as filled in the engine crankcase				See engine operating manual		When new or repaired fuel pump of the company Bosch, Germany is installed.
2.3	Transmission housing (clutch, GB and rear axle)	1	Engine oil M-10Г ₂ GOST 8581-78 (in summer)	Engine oil M-10B ₂ GOST 8581-78 (in summer)	Engine oil is the same as filled in the engine crankcase	Engine oil SAE 15W-40 (in summer)	(43±0,4)	seasonal, but at least 1000	without creeper
			Engine oil M-8Г ₂ GOST 8581-78 (in winter)	Engine oil M-10Г _{2к} (in summer) GOST 8581-78		Engine oil SAE 5W-40 (in winter)	Oil level shall be between marks «II» and «II»+7mm (55±0,4)		with creeper
2.4	Bracke housing 3)		Engine oil M-10Г ₂ GOST 8581-78 (summer)	Engine oil M-10B ₂ GOST 8581-78 (in summer)	Engine oil is the same as filled in the engine crankcase	Engine oil is the same as filled in the engine crankcase	(2,5±0,1) to the level of check plugs	seasonal, but at least 1000	
2.5	FDA body	1	Transmission oil ТАП-15B GOST 23652-79	Transmission oil ТАД-17и, ТСП-15K GOST 23652-79	Not available	HESSOL BECHEM HYPOID SAE 80W-90 API GL5/GL4	(3,7±0,04)	1000	Housing of FDA (with short beam)
			Transmission oil ТЭП-15M ТУ 38.401-58-305-2002	Transmission oil ТАД-17и, ТСП-15K GOST 23652-79, ТЭП-15M ТУ 38.401-58-305-2002		HESSOL BECHEM HYPOID SAE 80W-90 API GL5/GL4	(3,9±0,04)		Housing of FDA (with long beam)
2.6	Wheel-hub drive casing of FDA	2	Transmission oil ТАП-15B GOST 23652-79	Transmission oil ТАД-17и, ТСП-15K GOST 23652-79, ТЭП-15M ТУ 38.401-58-305-2002	Not available	HESSOL BECHEM HYPOID SAE 80W-90 API GL5/GL4	(4,0±0,04)	1000	

Table 5.4 continued

1	2	3	4	5	6	7	8	9	10
2.7	HSC tank with hydraulic unit	1	All-weather oils: hydraulic. BECHEM Staroil №32, №68 ADDINOL Hydraulikol HLP 32, HLP 68 THK Hydraulic HLP 32, HLP 68 HYDROL HLP 32, HLP 68 VITTOL HLP-32 LUKOIL Geiser 32CT, 68CT Gazpromneft Hydraulik HLP 32, HLP 68 ⁴⁾	Not available	Not available	Not available	(28,0±0,5)	1000 (first change 500)	
2.8	HSC tank with hydraulic unit	1	All-weather oils: hydraulic. BECHEM Staroil №32, №68 ADDINOL Hydraulikol HLP 32, HLP 68 THK Hydraulic HLP 32, HLP 68 HYDROL HLP 32, HLP 68 VITTOL HLP-32 LUKOIL Geiser 32CT, 68CT Gazpromneft Hydraulik HLP 32, HLP 68 ⁴⁾	Not available	Not available	Not available	(7,5±0,35)	1000 (first change 500)	

Table 5.4 continued

1	2	3	4	5	6	7	8	9	10
3 Greases and lubricants									
3.1	Hinged joint of the steering hydraulic cylinder	2	Grease Litol-24 GOST 21150-87	BECHEM LCP-GM	Not available	BECHEM LCP-GM	0,05 ±0.003	250	
3.2	Hinged joint of the steering link	2	Grease Litol-24 GOST 21150-87	BECHEM LCP-GM	Not available	BECHEM LCP-GM	0,02 ±0,001	1000	
3.3	Lifting rod of rear lift linkage ⁵⁾	2	Grease Litol-24 GOST 21150-87	BECHEM LCP-GM	Grease solid oil C GOST 4366-76 or grease solid oil Ж GOST 1033-79	BECHEM LCP-GM Mobil Grease MP ISO-L-XDCIB2	0,01 ±0,001	1000	
3.4	Clutch release yoke bearing	1	Grease Litol-24 GOST 21150-87	BECHEM LCP-GM	Grease solid oil C GOST 4366-76 or grease solid oil Ж GOST 1033-79	BECHEM LCP-GM	0,02 ±0,001	250	
3.5	Front drive shaft spider bearing of the twin hinged joint	2	Grease №158M TY 38.301-40-25-94	Grease AZMOL №158 TY Y 00152365. 118-2000	Not available		0,0112 ±0.001	One-time	Filled by the manufacturer, not refilled during operation
3.6	FDA drive universal-joint bearing	1	Grease №158M TY 38.301-40-25-94	Grease AZMOL №158 TY Y 00152365. 118-2000	Not available		0,0112 ±0.001	One-time	Filled by the propshaft manufacturer
3.7	FDA reducing gear pivot axle bearing	4	Grease Litol-24 GOST 21150-87	BECHEM LCP-GM	Grease solid oil C GOST 4366-76 or grease solid oil Ж GOST 1033-79	BECHEM LCP-GM	0,12 ±0.006	125	

End of table 5.4

1	2	3	4	5	6	7	8	9	10	
4 Special-purpose liquids										
4.1	Engine cooling system (with radiator)	1	<p>Low-freezing cooling fluid "Tosol- TC FELIX-40 Standart" (up to minus 40°C), "Tosol- TC FELIX-65 Standart" (up to minus 65°C), Technical specifications 2422-006-36732629-99 manufactured by LLC "Tosol-Sintez", Dzerzhinsk, Russian Federation</p> <p>Low-freezing cooling fluid "Tosol-AMP40" (up to minus 40°C) Technical specifications of the Republic of Belarus 101083712.009-2005 manufactured by RUE "Gomelchimtorg", Gomel, Republic of Belarus</p> <p>Low-freezing cooling fluid "CoolSteam Standard 40" (up to minus 40°C), Technical specifications 2422-002-13331543-2004 manufactured by JSC "Technoform", Klimovsk, Russian Federation</p> <p>Low-freezing cooling fluid "OЖ-40" (up to minus 40°C), "OЖ-65" (up to minus 65°C) Technical specifications 2422-047-51140047-2007 manufactured by "Obninskorgsintez", Obninsk, Russian Federation</p>	Cooling fluid OЖ-40 (up to minus 40°C), OЖ-65 (up to minus 65°C), GOST 28084-89	Not available	Not available	Not available	(26,5±0,2)	Once in two years	
4.2	Tank for fluid of SCR-system	1	Agent AUS 32 for reduction of NOX emissions as per STB ISO 22241-1-2009	Not available	Not available	Not available	(20,0±1,0)	Shift-time filling		
<p>¹⁾ According to Directive 2004/26/EC and Regulations of EEC of UN № 96 (02) (stage IIIA) fuel with sulfur content up to 0.3 g/kg (0,03 %)</p> <p>²⁾ Use of motor oils depending on operation conditions:</p> <p>a) summer (plus 5 °C and higher) – SAE 30; SAE 10W-40 (30); SAE 15W-40 (30); SAE 20W-40 (30);</p> <p>b) winter (minus 10 °C and higher) – SAE 20; SAE 10W-40 (30);</p> <p>c) winter (minus 20 °C and higher) – SAE 10W-20 (30, 40); SAE 5W-30 (40);</p> <p>d) winter (below minus 20 °C) – SAE 5W-30 (40); SAE 0W-30 (40).</p> <p>It is admitted to use other types of motor oil corresponding to classes E6, E9 under the classification of ACEA and to CI-4, CI-4+, CJ-4 under the classification of API, with viscosity conforming to the ambient temperature at the place of engine running.</p> <p>³⁾ When brakes operating in oil sump are installed against order.</p> <p>⁴⁾ Hydraulic types of oil HLP 68, No 68 68CT are used in tractors shipped to Venezuela.</p> <p>⁵⁾ For adjustable gear rod.</p>										

6. POSSIBLE MALFUNCTIONS AND GUIDELINES FOR TROUBLESHOOTING

List of possible failures of tractor "BELARUS-1025.5" and guidelines for troubleshooting are shown in Table 6.1.

Table 6.1

Malfunction, external manifestation	Troubleshooting
Clutch	
Clutch slips	
No free travel of the pedal.	Adjust free travel
Worn out driven discs lining	Replace driven disks' lining or disks in assembly.
Oiling of driven disks' lining	Remove causes of getting oil in dry clutch section and, if necessary, replace friction lining or disks in assembly
Warpage of the pressure disks	Replace them
Clutch is not fully engaged	
Increased free pedal travel.	Adjust free travel
Oil in dry section of the clutch body	
Wear of the cup, sealing the crankshaft	Replace
Loss of elasticity of the shifter arm due to overheating	Replace
Gear box, rear axle	
Difficult gear shifting	
Clutch is drifting	Make adjustment.
Low pressure in the GB hydraulic system	
Insufficient oil in transmission body	Add oil in the body up to mark "П" on the oil –measuring window glass.
Dip of the by-pass valve.	Wash the valve and, if necessary, adjust it.
Staining of GB hydraulic system meshed filter	Wash the filter
High pressure in GB hydraulic system	
Dip of the by-pass valve	Wash the valve.
Poor brakes operation (brakes do not hold)	
Disturbed adjustment of brakes control	Adjust brakes control.
Oiling of brake disks' lining	Wash lining. If necessary, replace disks.
Differential lock doesn't function	
Oily disks of lock coupling for tractors with dry brakes.	Eliminate oil leakage, wash disks
Worn out disks.	Replace disks.
Worn out friction lining of lock coupling	Replace disks in assembly.
Damaged diaphragm of lock coupling	Replace diaphragm.
Low oil pressure, supplied to interlock actuator.	Check pressure supplied to DL coupling. It should be 0.9... 1.3 MPa (9...13kgf/cm ²).

Table 6.1 continued

Malfunction, external manifestation	Troubleshooting
Rear PTO doesn't transmit full torque or keeps on rotating after switching off	
Low pressure in transmission hydraulic system	Eliminate the reason
Friction plates are worn out	Replace the plates
Sealing tightness of slave pistons of PTO gear group is disturbed	Replace rubber sealings
Oil leaks over the sealings of PTO gear group and PTO control valve	Replace sealings
Fail of hydraulic control system	Address skilled specialist.
Front driving axle Insufficient traction of front driving axle	
Drive coupling doesn't transmit torque:	
• no oil pressure in coupling booster	Disassembly and wash distributor parts.
• defects of the electric circuit of FDA control	Locate and eliminate defects
Insufficient magnitude of torque transmitted by coupling due to oil leakage in the hydraulic system:	
• drive coupling slippage	Replace rings. Check and adjust pressure in transmission hydraulic system to 0.9... 1.3 MPa (9... 13 kgf/cm ²).
Wear of rubber sealing rings;	Replace rings.
Wear of piston and coupling drum rings;	Replace rings.
Wear of coupling surfaces "shell-drum hub", "drum-piston"	Replace worn out parts
FDA drive doesn't function in the automatic mode	
Disturbed adjustment or failure of automatic switch on sensor	Adjust position of the automatic sensor switch or replace it
Increased noise and heating in the main gear zone	
Play in bearings of main gear pinions	Adjust pinions' bearings.
Wrong engagement of main gear pinions	Check and, if necessary, adjust engagement by contact pattern.
Noise at maximum angle of wheels turn	
Wrong mode of FDA operation. FDA operates in the forced mode.	Check the switching mode of FDA and set switch to position 'Switched on' or «Automatic».
Wrong extreme angle of wheels turn	Check and make adjustment.

Table 6.1 continued

Malfunction, external manifestation	Troubleshooting
Knock in the pivot during movement	
Disturbed adjustment of pivots' bearings	Check and make adjustment
Knock in FDA during sharp wheels turn	
Plays in pins of steering link and angle hydraulic cylinders.	Check and make adjustment
Lubrication leakage through the cup of main gear flange	
Wear or damage of flange cups	Replace worn out parts.
Lubrication leakage through breathers of wheel reduction gears	
High oil level.	Check and set correct level.
Leakage of lubrication through the cup of wheel reduction gear drive pinion	
Increased clearance in pinion bearings	Check and make adjustment
Wear or damage of the cup.	Replace the cup.
Angular oscillations of wheels	
Axial clearance in bearings of pivots wheel reduction gear.	Check and make adjustment
Increased clearance in front wheels bearings.	Check and adjust clearance in flange bearings.
Clearance in joints of steering tie-rod or joints of hydraulic cylinders.	Adjust clearances or replace worn out parts.
High wear and flaking of front wheels' tires	
Disturbed wheels' toe-in "Adjustments"	Adjust toe-in
Discrepancy between actual and recommended air pressure in tires.	Maintain necessary pressure in tires
Front axle is constantly switch on by force.	Check FDA switching on/off. When defects are found out, correct them.
Steering	
Increased force on the steering wheel	
No or insufficient pressure in the steering wheel hydraulic system due to:	Pressure in the steering wheel hydraulic system should be 140...155 kgf/cm ² (at stop).
• Insufficient oil level in the tank;	Fill tank with oil to the required level and bleed hydraulic system to remove air
• Supply pump doesn't develop required power;	Send the pump to repair or replace it.
• Safety valve hangs in the open position or set to low pressure;	Wash safety valve and set pressure to 140... 155 kgf/cm ²
• Considerable friction or wedging in mechanic components of steering column;	Check and eliminate causes, in hindering free travel of left-hand steering column
• Air ingress in the intake system	Check intake manifold, eliminate non-tightness. Bleed the system to remove air.

Table 6.1 continued

Malfunction, external manifestation	Troubleshooting
Steering wheel rotates without driven wheels turn	
No oil in the oil tank.	Fill the tank to the required level and bleed the hydraulic system to remove air.
Worn out sealing of hydraulic cylinder piston.	Replace sealing or hydraulic cylinder
Steering wheel doesn't return to "neutral", "motoring" of the metering pump	
Increased friction or wedging in mechanical elements of the steering column	Remove causes of friction and wedging
Increased play of the steering wheel	
Coned pins of hydraulic cylinders or steering tie-rod are not tightened	Torque pins' nuts to 12...14 kgf.m secure them with cotter-pins
Increased play of grooved connection "steering shaft gimbal gear – metering pump"	Replace lower gimbal gear yoke
Different minimal radii of tractor turn to the left-right	
Not adjusted wheels toe-in	Adjust wheels toe-in
FDA reduction gears extension doesn't correspond to installation of hydraulic cylinders	Adjust extension of reduction gears and installation of hydraulic cylinders depending on selected wheels span
Not complete turn of drive wheels	
Insufficient pressure in the steering hydraulic system.	Check and adjust pressure in steering system within 140...155 kgf/cm ² *
Defective supply pump.	Repair or replace the pump.
Hydraulic lift linkage	
Hitch without weight doesn't lift, when shifting any distributor handle to position "lift" or "lowering" characteristic sound made by pump under load is not audible	
Staining of tractor distributor safety valve	Disassembly and wash safety valve. Adjust pressure maintained by safety valve
Hitch without weight doesn't lift, when shifting one of the distributor handles to position "load", characteristic sound made by pump under load, is audible. After diesel shut down, transfer of position handle to front and then rear position and diesel start, the hinge is lifting (power handle should be in the front position).	
Clogging of jet opening in the unloading valve.	Dismount governor-distributor from tractor, pull out by-pass valve, rinse valve, clean valve jet opening.
Foreign particles under control valve edge.	Shift position handle to front position. Sink pusher of governor-distributor. Shift position handle to rear position; Pusher should move upwards by at least 7 mm. If distance is less, dismount governor-distributor, wash control valve and body.

Table 6.1 continued

Malfunction, external manifestation	Troubleshooting
Hitch with weight doesn't lift, or its lift is slow.	
The fault develops as oil heats up in the hydraulic system – faulty pump	Check pump capacity, if pump efficiency is less than 0.7., replace the pump
The defect develops at any oil temperature clogging of unloading valve.	Dismount governor-distributor, pull out by-pass valve, wash it and the body in diesel fuel.
Hitch with weight lifts slowly, after diesel shut down lowers visibly slowly on its own, frequent position corrections, possible pressure "hang up".	
Rapture of rubber sealing of governor-distributor	Dismount governor-distributor, replace rubber sealing for new one
The pump is not relieved in the whole range of hinge travel with load in the position control mode, when the hinge reaches given position	
With small movements towards lowering of position handle, the pump is relieved for short time. With diesel shut down air-tightness is normal - Jamming or loss of air-tightness of valve-accelerator	Dismount governor-distributor, pull out and wash by-pass valve. If necessary, caulk valve ball to its seat.
When moving position handle towards lowering, the pump is not relieved, with diesel shut down air-tightness is normal - loss of air-tightness of pressure adjusting valve.	Unscrew coned plug on the upper governor surface, remove spring, caulk valve ball to its seat
Hitch with load lowers a little all by itself after reaching position given by position handle (hinge "slump")	
Loss of air-tightness of anti-slump valve.	Unscrew coned plug on the upper governor surface, remove spring, caulk valve ball to its seat.
Position of the position handle on figures 1 and 9 doesn't correspond to transport and extreme bottom position of the hitch	
Adjustment of position steel rope in the drive is disturbed.	By rotating nuts, fixing position of steel rope to the arm in the panel, or the arm on the hydraulic lift, obtain matching of corresponding positions of handles and hitch.
Hitch without load doesn't lift, or lifts with jerks, with distributor switched on the pump "screams"	
Insufficient oil in the hydraulic system	Check oil in the oil tank, top it up, if necessary

Table 6.1 continued

Malfunction, external manifestation	Troubleshooting
Inadvertent movement of power and position handles across the panel	
Loosened spring load of friction washers on the panel arm	Using nuts, adjust spring loading on the arm axle, until defect is corrected
During ploughing or general cultivation in the power control mode, an implement jumps out of soil or goes too deep when power handle is slightly shifted	
Breakdown of power sensor spring	Replace the spring.
Electrical equipment AB has low charge degree	
Low level of voltage being regulated	Replace generator voltage regulator.
High contact resistance between storage battery terminals and wiring tips due to loosening and oxidation	Dress connection terminals, tighten and non-contact elements with technical cup grease. Tighten fastening of "ground" switch and "ground" junction.
Faulty generator (no voltage on terminals "+" and "D")	1. Replace generator voltage regulator 2. Dismount the generator and send to workshop for repair.
Faulty storage battery.	Replace the battery.
Accumulator battery "boils" and requires frequent topping up of distilled water	
High level of voltage being regulated	Replace generator voltage regulator.
Faulty AB.	Replace the battery.
Starter is not actuated and diesel crankshaft doesn't turn through	
Poor tension of storage battery terminals, or oxidation of wiring tips.	Dress tips and tighten terminals
Storage battery discharged below allowable limit	Charge or replace storage battery
Poor contact of brushes with collector	Dismount starter from diesel, dress the collector, correct hang up of brushes or replace them, if they are worn out
Slippage of starter drive coupling (wear of coupling or shell cracking).	Replace starter drive.
Diesel start locking device is actuated, its switch is defective	Shift GB levers to neutral position, check switch serviceability. If necessary, adjust switch position with adjusting washers.
Diesel is not made ready for start at low temperature below +5 °C	Get diesel ready for start at low temperatures

Table 6.1 continued

Malfunction, external manifestation	Troubleshooting
After diesel start starter remains in the engaged position	
Stuck contacts of control starter relay using (installed in the instruments panel)	Stop the diesel and switch off SB "ground" switch. Send starter and relay to workshop for repair.
Power disk is welded to contact bolts of starter relay	Shut down diesel. Send starter for repair
Driving pinion doesn't disengage the fly-wheel ring gear due to breakage of shifter lever spring	Shut down diesel. Send starter to workshop for repair
Generator noise	
Wear of bearings.	Dismount generator and send for repair
Cabin air heating and ventilation system Warm air is not supplied inside cabin	
Fluid doesn't circulate through heating unit:	
• ice plugs in heater hoses;	Crush ice, supply hot water through hoses
• heater fan doesn't function	Correct fan malfunction, check electric circuit of fan switching
• Heater valve is closed	Open heater valve
Too humid warm air is fed to cabin	
Fluid leakage in heater radiator	Eliminate leakage or replace radiator.
Fluid leakage in connections of heating system	Tighten coupling clamps of heater
Pneumatic system Slow build-up of pressure in the cylinder	
Air leakage from pneumatic system:	
• nuts of pipelines, fittings, coupling clamps are poorly tightened or damaged	Find out leakage sites and eliminate them by tightening couplings or replacing damaged parts
• rubber sealing of connecting head is damaged;	Replace damaged sealing
• nut of connecting head sealing ring is loose;	Tighten it
• mud under connecting head valve;	Clean it
• contact of dust-protecting cover with valve rod of the connecting head;	Eliminate it
• deformed valve parts, torn diaphragm, loose cover fastening in the brake valve	Check state of valve parts and, if necessary replace them, tighten fastening bolts..
• disturbed adjustment of valve drive	Adjust
• disturbed operation of pressure controller;	Dismount it and send to workshop for repair.
Air leakage via compressor valves.	Correct the compressor trouble
Hang up or wear of compressor piston rings	Correct the compressor trouble

Table 6.1 continued

Malfunction, external manifestation	Troubleshooting
Pressure in the cylinder drops fast upon diesel shut down	
Air leakage along pneumatic system connecting elements	Eliminate leakage
Pressure in the cylinder reduces quickly upon pressing brakes	
Brake valve inlet valve is askew, clogged or damaged	Eliminate skewness, clean the valve or replace it
Damaged diaphragm of the brake valve.	Replace diaphragm .
Insufficient pressure in the cylinder	
Air leakage.	Eliminate air leakage.
Disturbed operation of pressure regulator.	Adjust pressure regulator.
Defective inlet and delivery valves of the compressor	Correct the compressor trouble
Great wear of piston rings, hang up of compressor rings	Correct the compressor trouble
Compressor ejects oil in the pneumatic system	
Hang up or wear of compressor piston rings.	Correct the compressor trouble
Pressure regulator switches on controller to idle run at pressure less than 0.77...0.80 MPa (7.7...8.0 kgf/cm²), and to operation mode — at less than 0.65 MPa (6.5 kgf/cm²), or over 0.70 MPa (7.0 kgf/cm²)	
Staining of cavities and ducts of pressure regulator	Wash and clean them
Unlocking of adjustment cover.	Adjust pressure of compressor switching on/off
Loss of elasticity, damage or breakage of rubber parts, spring shrinkage	Replace damaged parts
Skewness, hang up of controller regulating section	Check valves mobility, put grease, if required
Pressure regulator is often actuated (switches compressor on) without air intake from the receiver	
Air leakage from pneumatic system or pressure regulator, or damage of the controller check valve	Find out and eliminate air leakage
Regulator operates in the safety valve mode	
Adjusting cover is screwed up to great value	Adjust controller
Jamming of discharge piston of the diaphragm unit	Disassembly pressure controller and eliminate jamming
No clearance between relief valve and lower cover, cover outlet openings are clogged	Unscrew cover, clean outlet openings and check for clearance
No air supply to connecting hose via air bleed off valve	
Rod of air bleed off valve in the pressure controller is not sunk enough.	Screw up connecting hose nut to the coupling to the full.
Pressure controller has switched compressor over to idle run	Reduce cylinder pressure to below 0.65 Mpa (6.5 kgf/cm ²)
Displacement of rubber ring on the air bleed off valve	Unscrew the cover, check position and state of rubber ring.

Table 6.1 continued

Malfunction, external manifestation	Troubleshooting
Trailer brakes are inefficient	
Brake valve doesn't provide in the control main pipeline pressure 0.77...0.80 Mpa (7.7...8.0 kgf/cm ²) or 0.53...0.6 Mpa (5.3...6.0 kgf/cm ²) for Hungary and Germany.	Make adjustment of brake valve and its drive
Brake valve doesn't provide pressure drop in the connecting pipe-line to zero	Make adjustment of brake valve and its drive
Pressure in the connecting pipe-line slowly drops to zero	Check state of connecting main pipe-line; atmospheric valve opening, brake pedal travel.
Disturbed operation of trailer brake system	Adjust it
Trailer brakes are released slowly	
Disturbed adjustment of brake valve and its drive	Adjust it
Disturbed operation of trailer brake system	Adjust it
Control of DL and FDA (electrical part) Rear axle DL or FDA drive are not switched on in the forced mode.	
. No voltage is supplied to corresponding electromagnet of electric-hydraulic distributor.	Check voltage supply to electromagnet by electric circuit diagram. Check electromagnet winding (winding resistance should be 4...7 Ohm)
No oil pressure at distributor outlet	Check pressure at the distributor outlet. Correct malfunction in the hydraulic system.
Rear axle DL doesn't switch on in the automatic mode with drive wheels position "straight"	
Sensor of drive wheels turning angle, located on the FDA left side, doesn't operate.	Check serviceability of circuit to the sensor according to diagram Check sensor operation: - with position of driving wheels "straight" , sensor contacts shall be closed; - when driving wheels turn by an angle over (13+/-2) degrees, sensor contacts should open. If necessary, adjust sensor operation with adjusting washers
FDA drive doesn't switch on automatically when rear wheels slip.	
Sensor of FDA drive automatic control, located under the distributor, doesn't operate.	Check serviceability of circuit to sensor by diagram Check sensor operation: - with no rear wheels slippage sensor contacts shall be open. - when rear wheels slip sensor contacts should close. If necessary, adjust sensor operation with adjusting washers

Table 6.1 continued

Malfunction, external manifestation	Troubleshooting
During tractor braking (pressing both brake pedals at the same time) FDA drive doesn't switch on.	
One or both sensors of brakes switching on) don't operate.	One by one imitate sensors' operation by closing contacts of cable assembly connectors to sensors.
Faulty cable bundle or relay.	Check their serviceability
When putting switch of drive control of rear axle FDA or DL to position "Switched off" (middle position) relative distributor doesn't switch off channel remains open).	
Distributor control valve "hangs up" in position "switched on"	Disassembly and wash hydraulic distributor in diesel fuel.
Conditioner	

Compressor electromagnetic coupling will not respond (no metallic click while turning temperature regulator)	
Electric equipment failure	By means of tester or multimeter check operability of pressure sensors unit, sensors unit outputs (red and pink wires) should be "rung out" among themselves. Check up operability of electric circuits connections from compressor coupling to air conditioner control console according to the electrical equipment diagram in Annex C
Coolant leakage took place	Detect leak path. Only specially trained personnel is allowed to detection of leak path, replacement of hoses and air conditioner components with use of special equipment (after-sales service and repair should be carried out by CJSC "Belvneshinvest", Minsk, tel./fax 8-017-262-40-75, 8-029-662-97-69, 8-029-628-67-98)
Nonoperable conditioner fan electric motor	
Electric equipment failure	Check up operability of the corresponding fuse element located in the switching unit. Replace if it is faulty. If the safety lock is properly operating check by means of indicating lamp power supply presence on the electric motor of air conditioner fan (M2, Appendix C) when the switch is on and "ground" is available in electric motor. If electric circuits are properly operating, but there is lack of power supply to M2, replace the switch.
When air conditioner operated in cooling mode warm air is supplied into cab	
Valve PO-11 seal element breakage	Replace valve PO-11
Coolant leakage from cab ventilation compartment	
Disruption of heating unit tubes (heating unit "defrosting" due to incomplete drain during cool weather period operation)	Replace conditioner climatic unit

Note – List of possible malfunctions of D-245 S3B engine and guidelines for their troubleshooting are given in engine operating manual 245S3B-0000100 OM.

7 TRACTOR STORAGE

7.1 General instructions

ATTENTION: THE PRESENT SECTION CONTAINS THE STORAGE REGULATIONS FOR TRACTOR "BELARUS-1025.5" CHASSIS SYSTEMS AND UNITS. ENGINE STORAGE, PRESERVATION, REPRESENTATION, DEPRESERVATION REGULATIONS ARE SPECIFIED IN THE ENGINE OPERATION MANUAL!

The tractors shall be stored in the indoor area or under a shed.

If indoors premises are not available, tractors may be stored on outdoor special sites, with obligatory preservation, sealing and components dismounting, that require warehousing.

Put tractors in the inter-shift storage, if their operation is interrupted for up to 10 days, short-term storage if duration of idle interval is from ten days to two months, and long-term storage if interruption of use lasts for over two months. Start preparation for short-term storage straight after works completion, and for long-term storage – not later than ten days after works termination.

7.2 Requirements for inter-shift storage of machines

Tractor may be stored on storage yards, and inter-shift storage grounds, or directly on works execution sites. All openings, through which atmospheric precipitation can get inside tractor cavities, shall be tightly covered. Accumulator batteries shall be switched off.

7.3 Requirements for short-term tractors storage

Put tractor in storage in complete set without dismounting parts and assembly units.

Disconnect the accumulator battery. Carry out regular maintenance of accumulator batteries.

To carry out AB maintenance, perform the following actions:

- open tractor hood;
- clean the battery from dirt and dust;
- check state of terminals 2 (Figure 7.3.1) of the output pin connectors, placed under the protecting cover "A" (Figure 7.3.1), and ventilating openings in plugs 1. When necessary, grease the terminals with technical petroleum jelly and purge the ventilating openings;
- unscrew the plugs 1 of the filler openings of the accumulator batteries and check:
 1. electrolyte level – if necessary refill the distilled water in order to increase the electrolyte level by 10...15 mm above the protective grid or up to the level of mark on the battery case.
 2. degree of battery discharge by the electrolyte density - recharge the battery if necessary Degree of battery discharge shall not be lower than 50% in summer and 25% in winter.

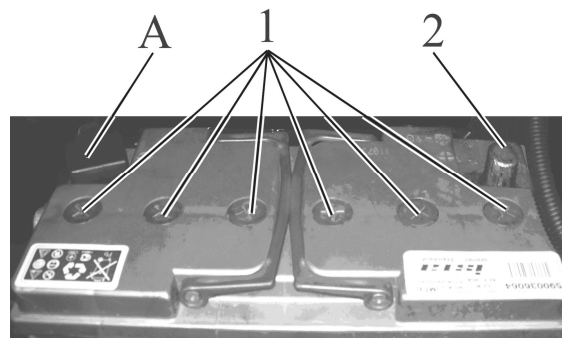

1 – terminal of output pin connector; 2 – filler plug.

Figure 7.3.1 – Maintenance of accumulator battery

If tractor is stored at low temperatures or over one month, accumulator batteries must be dismounted and sent to warehouse.

7.4 Requirements for outdoors long-term storage

Before putting a tractor in the storage check its technical condition. Carry out basic maintenance services.

Technological maintenance when preparing tractor for long-term storage includes:

- cleaning and washing;
- dismantling and preparing for storage tractor components subject to storage in specially equipped warehouses;
- sealing of openings and cavities from ingress of moisture and dust;
- tractor and its components' preservation;
- putting tractor on supporting blocks (plates).

After operation the tractor must be cleaned off dust, mud, oil leaks, vegetation and other remains. Components where water is not allowed (generators, relays, etc.), are protected with protecting cover. After tractor is cleaned and washed, it must be blown off with compressed air to remove moisture. Damaged painting is restored by putting varnish and paint coating or protective grease.

Painting shall be carried out according to GOST 6572-91.

With long-term outdoor storage, electrical equipment, components made of rubber, polymer and textile materials (hydraulic circuit hoses, etc), are dismantled, prepared for storage and sent to warehouse. Fastening parts of dismantled tractor components shall be mounted back in their places. Electrical equipment (headlights, generator, starter, accumulator batteries) are cleaned, blown with compressed air, terminals are coated with protective grease.

When preparing a tractor for long-term storage, carry out internal and outside preservation procedures for the engine according to the engine operation manual. Lubricate all tractor units according to clause 3 of Table 5.4 of the present operation manual. Drain oil and fill fresh oil with the required amount of additives up to the control level on the transmission body, FDA reducing gears, HLL and HSC oil tank. Run the tractor for 10-15 minutes. Put accumulator batteries in long-term storage after conducting control-training cycle in accordance with GOST 9590-76. Projecting joints, threaded connections of lift linkage mechanism, steering geometry, splined surfaces of PTO shaft end extension and of cardan shafts, and projecting parts of cylinder rods and shock absorbers, front and rear track adjusting mechanism should be preserved. Cover carefully fuel tank filling neck, diesel breathers' openings, transmission, hydraulic systems, engine exhaust pipe and inlet air purifier pipe, relative openings after starter removal, and other cavities, through which atmospheric precipitation may get inside inner cavities of a tractor assembly units with caps, polyethylene film sacks or other special accessories. Set shift levers and pedals to a position excluding spontaneous engagement of tractor units and implements.

Only pneumatic tires unloaded are allowed for outdoor storage on tractors, resting on supports. Tire surface should be covered with protective agent. Tires pressure should be decreased up to 70% of the standard. Clean exterior surfaces of the hydraulic system flexible hoses off mud and oil. Hoses may be kept on the tractor. In this case they are coated with protective substance or wrapped with insulating material (wax paper, polyethylene film, etc).

Cabin hoods and doors should be closed.

Maintenance during storage includes checking if machines are properly placed on supporting blocks (plates) (absence of cocking), completeness, air pressure in tires, air-tightness, state of anticorrosion coatings (protective grease, paint integrity, absence of corrosion (integrity and strength of sheathes and covers). Detected defects should be corrected.

Tractor technological maintenance when removing from storage includes taking off supporting blocks, cleaning and, if required, depreservation of tractor, its components, removal of packoff, reinstallation of dismantled components, tools, check of operation and adjustments of tractor and its components.

7.5 Preservation

Preservation provides provisional anticorrosion protection of tractor assemblies and systems from ambient exposure in the process of tractor transportation and storage.

Engine, its systems and fuel tank preservation instructions are listed in the engine operation manual.

Clean tractor surfaces subject to preservation from mechanical staining, degreased and dried up. Cover unpainted inside and outside galvanized surfaces, specific assemblies of tractor and cabin with corrosion-proof oil RUST BAN 397, SUMIDERA 397.

Preservation of units (radiator and fuel tank filler, breathers, cylinder rods) is carried out by polyethylene film.

Materials used provide protection of tractor and its assemblies for the period of storage and transportation within one year.

Outside tractor and its assemblies preservation is made by lubrication of surfaces using brush or sputtering by means of paint sprayer. Inside tractor preservation is carried out by filling cavities with preservation mixture and subsequent engine operation.

During tractor inter-shift, short-term and long-term storage, the enterprise operating the tractor is liable for compliance with preservation methods and storage conditions specified in GOST 7751-85. Inside tractor surfaces preservation is carried out by preservation grease KC-Y according to TU RB 600125053.019-2004. When a tractor is stored outside, specific surfaces must be preserved with grease "BELA-COR" of type "A" according to TU RB 600125053-020-2004. Upon agreement with Minsk Tractor Works other preservation greases can be used.

7.6 Depreservation and reprereservation

Depreservation method is chosen depending on preservation materials used. Surfaces under preservation have to be wiped with cleaning cloth soaked with low-viscous oils, solvents, or washed away with washing water-soluble detergents. Sealed assemblies should be stripped off insulation materials (film, paper). Inside surfaces under preservation need no depreservation.

Tractor reprereservation is carried out in case conservation defects are detected in the process of storage or upon expiration of protection life.

7.7 Putting tractor into operation after long-term storage

Perform depreservation of an engine according to the engine operation manual.

Remove grease off external surfaces under preservation. Dismount protective covers, plugs, special accessories and mount the parts which were removed earlier back in their places. Before mounting parts clean them off grease and dust. Drain sediment out of all vessels, fill them with operation fluids and, if necessary, top up to control level.

Lubricate all tractor mechanisms according to clause 3 of Table 6.4 of the present operation manual. Carry out scheduled maintenance. Run tractor for 15-20 minutes. Correct detected faults if necessary.

7.8 Safety requirements for preservation

The preservation procedure, comprising surfaces preparation, coating with preservation materials, paper marking and cutting, packing, shall be carried out only by persons of the age, subjected to medical examination, properly instructed on labor and fire safety, and receiving primary instructions on the working place. Preservation remises and sections should be separated from other production premises and equipped with plenum-exhaust ventilation. Materials used for preservation are combustible substances with flash temperature from 170 to 270°C, and should comply with state standards, technical specifications and have quality certificate.

Conservation materials being supplied should bear label with material description. Perform preservation operations in special clothes and footwear and use individual protection means. When performing preservation operations, observe personal hygiene rules, dry clean special clothes in time, don't wash it in emulsions, solvents, kerosine. By the degree of impact on human health, preservation materials are classified as of moderate hazard, so use recommended individual protection means while handling materials.

With prolonged exposure of skin to preservation oils, greases and liquids, it may be injured. White spirit vapors in small concentrations act as weak drug, large concentration may result in poisoning. Anticorrosion paper contains corrosion inhibitors causing irritation and inflammation of skin, mucous of nose and eyes. Before starting work put on cotton overalls, robe or apron, prepare individual protection means depending on work conditions and toxicity of substances used. Grease hands with protection paste (cream) and put on cotton and rubber gloves. Before starting work, safe conditions of which are not known, claim for safety inductions.

8. TRACTOR TOWING

Towing of tractor is allowed at a speed of not more than 10 km/h for a distance of 5 km. Before starting tractor towing do the following:

- set the range selector lever and change gear lever to a "Neutral" position.
- set selector handle of RPTO to switch from independent to a synchronous drive to a "Neutral" position.

In order to connect a towing rope on tractors with mounted ballast weights there is a towing yoke located on ballast weights.

In case the tractor is towed without the front ballast weights, the towing rope shall be fastened to the towing yoke located on four apertures of tractor front beam.

THE TOWING SHACKLE MUST NOT BE USED TO LIFT THE TRACTOR!

ATTENTION: DURING TOWING OF THE TRACTOR OBSERVE THE TRAFFIC REGULATIONS RIGIDLY!

Service bulletins